

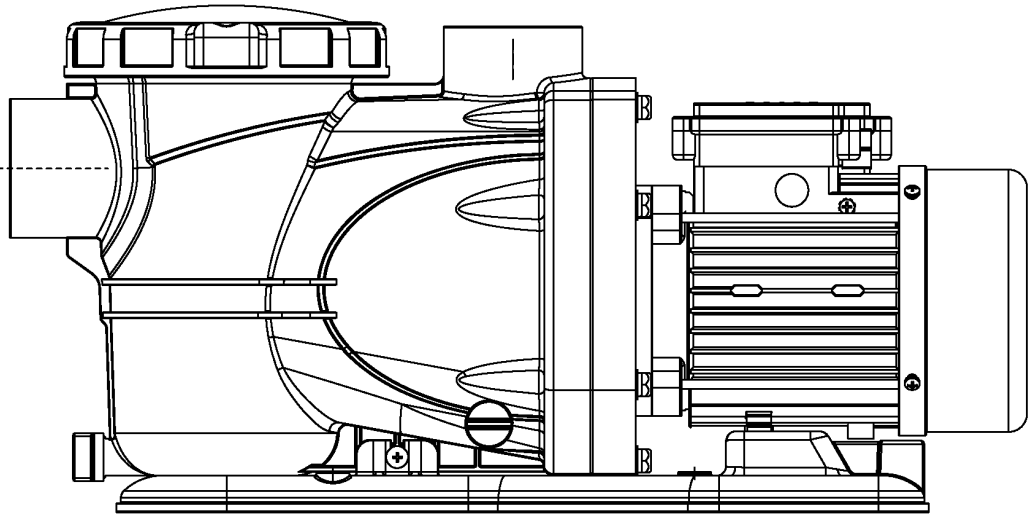

# SINGLE SPEED POOL PUMPS



## INSTALLATION & OPERATION MANUAL

HY-CLOR AUSTRALIA PTY LIMITED  
ABN: 81 000 655 381

178 Power Street  
Glendenning, NSW 2761 Australia

All enquiries  
AU: 1800 625 123 NZ: (09) 973 2477  
or [help@hyclor.com.au](mailto:help@hyclor.com.au)

Visit us at [hyclor.com.au](http://hyclor.com.au)



This equipment must be installed and serviced by a qualified technician. Improper installation can create electrical hazards which could result in property damage, serious injury or death. Improper installation will void warranty.



### INSTALLERS NOTE:

The supplied manual provides the consumer valuable information about the installation and ongoing safe operation of this product. Once you have handed over or installed this product the manual must be given to the owner or operator of this equipment.

suits:  
0.75hp pump : SPS125 (SPS3 600)  
1.0hp pump: FOBPP10 (Type 72543)  
1.5hp pump: FOBPP150 (Type 72544)

Mar 2025

Version 3.1



# SINGLE SPEED POOL PUMPS

## INSTALLATION AND OPERATION MANUAL

0.75hp pump : SPS125 (SPS3 600)  
1.0hp pump: FOBPP10 (Type 72543)  
1.5hp pump: FOBPP150 (Type 72544)

1.0	INTRODUCTION .....	3
2.0	SAFETY INFORMATION .....	3
3.0	INSTALLATION .....	4
4.0	OPERATION .....	5
5.0	SERVICE AND MAINTENANCE .....	6
6.0	TROUBLESHOOTING .....	7
7.0	WARRANTY .....	7
8.0	TECHNICAL SPECIFICATIONS .....	10
9.0	SPARE PARTS DIAGRAMS .....	13



### PRODUCT HELPLINE

Australia: 1800 625 123  
New Zealand: (09) 973 2477

## 1.0 INTRODUCTION

- 1.1 Congratulations on your recent purchase of a HY-CLOR Pump. Please take a moment to read through the entire manual before installing your new pump. Your pump must be installed and operated as specified.
- 1.2 **Please ensure the pump specifications for the filter size are followed, as installing a pump that is too powerful for the filter may void both the filter and pump warranties. Specifications can be found on the box and in section 8.0 of each pump manual.**

## 2.0 SAFETY INFORMATION

- 2.1 **IMPORTANT SAFETY INSTRUCTIONS, READ AND FOLLOW ALL INSTRUCTIONS. SAVE ALL INSTRUCTIONS.**
- 2.1.1  **WARNING:** Hazardous Suction. Pump suction is hazardous and can trap hair and body parts resulting in severe injury or death. Do not block filtration suction lines with any part of your body. If someone becomes trapped, immediately turn the pump off.
- 2.1.2  **WARNING:** Two suction inlets (minimum 500mm apart) must be provided into every pump to avoid suction entrapment. If a suction cover is broken, missing or loose, do not operate the swimming pool or spa.
- 2.1.3 A qualified technician **should** carry out the pump installation.
- 2.1.4 Always wear protective clothing and gloves when handling adhesives.
- 2.1.5 The pump must be installed and operated in accordance with national wiring rules.
- 2.1.6 Children should be supervised to ensure they do not play with the appliance.
- 2.1.7 If the power supply cord is damaged, it must be replaced by the manufacturer, its service agent or similarly qualified persons in order to avoid a hazard.
- 2.1.8 This appliance is not intended to be used by persons (including children) with reduced physical, sensory or mental capabilities, or lack of experience and knowledge, unless they have been given supervision or instruction concerning use of the appliance by a person responsible for their safety.
- 2.1.9 The pump power must be supplied through a residual current device (RCD) having a rated residual operating current not exceeding 30mA.
- 2.1.10 Routinely check the pump basket, skimmer and entire pool system to maximise the life of the pool equipment and personal safety. Always turn the pump off before carrying out checks and maintenance.
- 2.1.11 **DO NOT** remove any safety alert labels on the pump such as DANGER, WARNING or CAUTION. Keep safety labels in good condition and replace missing or damaged labels.

---

### PRODUCT HELPLINE

**Australia: 1800 625 123**  
**New Zealand: (09) 973 2477**



## 3.0 INSTALLATION

### 3.1 LOCATION

- 3.1.1 Locate the pump as close to the pool as practical and in accordance with any relevant regulations or recommendations.
- 3.1.2 The pump must be installed in a dry and well-ventilated position protected from the elements.
- 3.1.3 A clearance of 250mm is required behind the motor for ease of removal and ventilation.
- 3.1.4 The pump must be installed horizontally, at 3 metres maximum below or maximum 0.3 metres above the pool water level without consulting manufacturer.
- 3.1.5 DO NOT store or use gasoline or other flammable gases or liquids in the vicinity of this pump. DO NOT store pool chemicals near the pump.
- 3.1.6 Flooding or moisture in the motor voids warranty. Ensure the pump is elevated and kept dry and free from flooding.

### 3.2 PLUMBING CONNECTION

- 3.2.1 The piping should be as direct and free from turns or bends as possible as elbows and other fittings can greatly reduce flow efficiency.
- 3.2.2 If the pump is located below water level, isolation valves must be installed on both sides of the pump to prevent the back flow of pool water during any routine or required servicing.
- 3.2.3 Use PVC fittings for all connections. Suction inlet/outlet union is provided to suit **40mm PVC pipe**. The suction and discharge pipes must not be smaller in diameter than the pump fittings (otherwise flow rates may be affected).
- 3.2.4 Use plumbing cleaner primer to clean and prepare the pipe ends and do not use primer on unions - only pipe work. Place the union collars over the pipe ends use Type P plumbing solvent cement (clear or green) for pressure pipe connections only, as blue glue is not pressure-rated and using the wrong adhesive may void your warranty; ensure you allow at least 24 hours for the glue to cure before starting the pump.
- 3.2.5 Ensure that the o-rings are fitted to the union sockets and apply a non petrol based lubricant as required. Also check that the pump basket lid o-ring is sufficiently lubricated.
- 3.2.6 Suction and discharge lines should be independently supported at a point near the pump to avoid strain being placed on the pump.

---

## PRODUCT HELPLINE

**Australia: 1800 625 123**  
**New Zealand: (09) 973 2477**

### 3.3 ELECTRICAL CONNECTION

- 3.3.1 HY-COLOR pumps are suitable for connection to a nominal 220-240VAC 50hz power supply.
- 3.3.2 The motor is equipped with a flexible cable and 3-pin plug. If a power outlet is not available within 2 metres of the pump, a 3-pin power point in a safe dry place will need to be provided by an electrician.
- 3.3.3 The pump power must be supplied through a residual current device (RCD) having a rated residual operating current not exceeding 30mA.
- 3.3.4 Extension cords are unsafe around pools and must be avoided

## 4.0 OPERATION

### 4.1 GENERAL START UP GUIDE

- 4.1.1 CAUTION: Never run the pump without water. Running the pump "dry" for any length of time can cause severe damage to both the pump and the motor and will void the warranty.
- 4.1.2 If it is a new pool installation, make sure all piping is clear of construction debris and has been properly pressure tested. Special care must be taken to ensure no small pebbles are ingested into the pump as this voids the warranty.
- 4.1.3 The filter should be checked for proper installation, verifying that all connections are secure according to the manufacturer's recommendations.
- 4.1.4 Depending on the location of the pump, do one of the following:
  - a) If the pump is located below the water level of the pool, open the filter pressure valve to prime the pump with water.
  - b) If the pump is located above the water level of the pool, remove the lid and fill the basket with water before starting the pump.
- 4.1.5 Prior to replacing the lid, check for debris around the lid o-ring seat. Debris around the lid o-ring seat will make it difficult to prime the pump and may damage the o-ring.
- 4.1.6 Hand-tighten the lid to make an air tight seal (do not use any tools to tighten as damage may occur).
- 4.1.7 Make sure all valves are open and the unions are tight. Turn on the pump, the pump will take a short time to prime and then deliver at full rate. No further priming should be required.
- 4.1.8 If prime is not established within approximately two minutes (as evidenced by a strong flow of water from the outlet) switch off the pump and repeat the procedure above (5.1.4 through 5.1.7).
- 4.1.9 If bubbles persist under the lid there is a leak in the suction connections or the lid is not sealed properly, switch off the pump and repeat the procedure above (5.1.5 through 5.1.7).

---

## PRODUCT HELPLINE

**Australia: 1800 625 123**  
**New Zealand: (09) 973 2477**



## 5.0 SERVICE AND MAINTENANCE

- 5.1.1 To achieve a maximum potential life expectancy from the pump ensure the following steps are taken:
- 5.1.2 Empty the skimmer basket regularly (weekly recommended). The regularity will vary from pool to pool, for example:
- Where you may have lots of leaves and debris you should empty the basket twice or more for each operating cycle, particularly when using a suction type cleaner.
  - Where you may have minimal leaves and debris the basket may only require checking weekly.
  - Always remove children's toys or balls from the pool when not in use.
- 5.1.3 Check for leakages. Carry out weekly inspections, for example:
- Around the pump, filter, chlorinator and heater (where fitted) where water can leak from all or some of these components.
  - If water is present whether you can see the source of the leak or not, then contact your pool technician immediately. This may reduce the possibility of major equipment damage.
- 5.1.4 Inspect and empty the pump lint basket at least weekly.
- Turn pump OFF at the mains power supply.
  - Close all valves where fitted, to prevent water loss through pump.
  - Remove clear plastic screw-down lid off the pump.
  - Remove plastic basket and empty any contents. If a sock or filter has been fitted, inspect it for holes and replace if necessary.
  - Inspect the chamber housing of the basket, ensure no debris, pebbles or leaves have fallen in whilst removing the basket, remove all foreign material.
  - Return the basket into the chamber and ensure it is correctly seated to avoid any damage to the pump.
  - Lubricate the o-ring. The o-ring can be located on top of the chamber where the lid screws on, use a silicone lubricant which is available from your retailer or serviceman (Do NOT use petroleum gel or axle grease as this will damage the o-ring).
  - Replace the screw-down lid firmly by hand only.
  - Re-open any valves where fitted that were closed in step (b) above.
  - Operate the pump. It is essential that the pump be operated after carrying out the above procedure, this will purge any air from the system. Start the pump and wait until the lint basket is full of water. Then where fitted, open air bleed fitting on the filter to expel air. Once the stream of water emerges all air is gone and the air bleed valve can be closed.
- 5.1.5 Dirty Filters. Restricted water flow from a dirty filter can cause the pump to overwork thus shortening it's lifespan. Please follow the filter manufacturer's guidelines for the method and frequency of cleaning.
- 5.1.6 Noisy Pump. As with all mechanical devices, if more noise than usual is heard coming from the pump, notify Hy-Clor or your pool service technician. A noise can indicate a fault and the longer this is left unattended the risk of increased damage can occur resulting in an expensive repair or replacement.

---

### PRODUCT HELPLINE

**Australia: 1800 625 123**  
**New Zealand: (09) 973 2477**

- 5.1.7 Pebblecrete Pools. All pebblecrete or similar pools should initially be fitted with a sock in either the skimmer basket or in the pump lint basket to prevent damage to the pump as a result of loose stones making their way through the system. Should a sock not be installed, any subsequent damage caused by loose pebble entering the pump impeller will void the warranty.

## 6.0 TROUBLESHOOTING

- 6.1.1  **WARNING:** Your pump must be serviced by a professional service technician qualified in pool / spa installation. The following procedures must be followed exactly. Improper installation and / or operation can create dangerous electrical hazards, which can cause high voltage to run through the electrical system. This can cause property damage, serious personal injury and / or death. Improper installation and / or operation will void the warranty.

### 6.2 GENERAL PUMP TROUBLESHOOTING

PROBLEM	POTENTIAL CAUSE	CORRECTION
Pump won't prime	Air in system No water in the pump lint pot Not enough water in pool	Ensure that there is sufficient water in the pool. Tighten all fittings including the lid. Lubricate the o-ring. Fill hair and lint pot with water. Ensure all valves are open and in their correct positions. Remove any debris from baskets.
Motor won't switch on	No power to pump Pump over heating	Make sure that power supply to the pump is on. Check and reset circuit breakers. Check timers. Ensure that the pump is not covered and has adequate ventilation.
Poor water flow	Dirty filter Full skimmer box Full hair and lint basket Valve shut or blocked	Backwash or clean filter properly. Clean baskets of debris. Ensure all valves are open and in their correct positions.
Noisy Pump Sound	Air in system Debris caught in impeller Bearings in motor faulty	Note: Debris in the impeller is not considered a warranty matter. Open the pump and remove the debris.

## 7.0 HY-CLOR WARRANTY

- 7.0.1 Our goods come with guarantees that cannot be excluded under the Australian consumer Law. You are entitled to a replacement or a refund for a major failure and for compensation for any other reasonably foreseeable loss or damage. Please read these warranty terms and conditions carefully. A failure to comply with these terms and conditions may affect any claim on warranty you may have on a product.
- 7.0.2 All products provided by HY-CLOR AUSTRALIA PTY LTD are warranted for defined periods of time (refer to warranty terms)..
- 7.0.3 All mechanical swimming pool products supplied to consumers by HY-CLOR are to be installed or used in the manner they are manufactured for only.
- 7.0.4 Warranty may be voided if the product or products claimed by the consumer under warranty have been used for purposes other than their designed or manufactured purpose.
- 7.0.5 Where applicable, products supplied by HY-CLOR come with operation and installation manuals. All care must be taken to install and operate the products according to these instructions. Failure to install or operate these products in accordance with these instructions may void warranty.

### PRODUCT HELPLINE

**Australia: 1800 625 123**  
**New Zealand: (09) 973 2477**



- 7.0.6 The chemical balance of the swimming pool water plays a significant part in the operational life of all swimming pool products, HY-CLOR recommends regular water testing using an approved swimming pool test kit or test strips - This is provided on our website's SMART STEPS - <https://hyclor.com.au/smart-steps/test/>
- 7.0.7 This warranty is valid for the original purchase and is not transferable. Keep your purchase docket, tax invoice or receipt as the proof of purchase, and as proof of the date on which the purchase was made.
- 7.0.8 Modifications to any electrical product provided by HY-CLOR products are covered by a twelve month warranty unless prior written approval has been granted by HY-CLOR and has been carried out by one of its authorised agents. All electrical installations must be carried out by a competent licensed professional.
- 7.0.9 All pool filtration equipment including filters, pumps and salt chlorinators, must be kept in a dry well ventilated area away from direct sunlight and in an area that is free from flooding or rain. This warranty does not cover normal wear and tear to the products or parts.

## 7.1 WARRANTY TERMS

- 7.1.1 Your HY-CLOR Pump Carries a manufacturer's warranty of 2 years on the Pump body, Motor, Body O-ring Mechanical Seal and Lid.
- 7.1.2 All other Components including o-rings are 1 year warranty, but subject to wear and tear.

## 7.2 EXCLUSIONS

To the maximum extent permitted by Applicable Laws, the warranty will not apply under any of the following circumstances:

- 7.2.1 The Purchaser is in breach of the terms and conditions of sale.
- 7.2.2 The product was used for a purpose or under conditions other than what it was intended for.
- 7.2.3 The product was repaired, modified or altered by any person other than HY-CLOR Authorised Representatives.
- 7.2.4 The product was not installed, maintained and/or operated in complete compliance with the installation and operating instructions and any instructions provided by HY-CLOR.
- 7.2.5 The product was operated under adverse conditions including, but not limited to, use with water exceeding 35°C, hot operating enclosures with poor ventilation, fluctuating power supplies, water pressure greater than 250kpa, or lack of protection from the weather.
- 7.2.6 Normal wear and tear or deterioration associated with the age or use of the product.
- 7.2.7 The product was damaged by foreign debris entering via suction pool cleaners, refer to equipment installation instructions. Damage to the product caused by the addition of chemicals, salt filter media or any other thing through the skimmer box.
- 7.2.8 The product was damaged by weather and other environmental conditions including but not limited to storm, flood, and/or heat wave damage.
- 7.2.9 Failure of the mechanical seal due to insufficient water flow caused by any blockage or ingress of foreign matter of any kind whatsoever.
- 7.2.10 pumps installed outside the recommended specifications for filter size may also void the warranty
- 7.2.11 Failures or any defects in component, part or operating function of the product, which is in the opinion of HY-CLOR the result from misuse, negligence, rebuilds or modification, incorrect installation by persons that are not HY-CLOR Authorised Representatives.

---

## PRODUCT HELPLINE

**Australia: 1800 625 123**  
**New Zealand: (09) 973 2477**



### 7.3 LIMITATIONS

Except to the extent permitted by applicable laws, breach of a condition or warranty, shall be limited to replacing or acquiring the same equipment (or any part thereof) or the services supplied.

The maximum liability incurred by HY-CLOR shall not exceed in any case the contract price for the equipment or the product parts claimed to be defective. Further, HY-CLOR shall not be liable for any loss, damage or delay directly or indirectly caused by any malfunction of or defect of or failure of the equipment other than as expressly stated in this warranty.

Subject to applicable laws, the repair or replacement of the product or part of the product is the absolute limit of Hy-Clor liability under this express warranty.

### 7.4 WARRANTY CLAIMS

If you consider that the product which you have purchased is not of acceptable quality, has a latent defect or is otherwise not compliant with the warranties, conditions, undertakings and legal rights you have under Applicable Laws you can make a claim under this warranty by contacting:

HY-CLOR AUSTRALIA  
178 Power Street, Glendenning NSW 2761  
Phone: +61 2 8805 2400  
Fax: +61 2 8805 2401  
AUS: 1800 625 123  
NZ: (09) 9732 2477  
Email: [help@hyclor.com.au](mailto:help@hyclor.com.au)

All Warranty claims must be accompanied by the proof of purchase, alleged defect and any appropriate documentation (Historical and maintenance records).

### 7.5 CUSTOMER WARRANTY INFORMATION

- 7.5.1 Please complete the *WARRANTY CERTIFICATE* at time of installation and retain in the event you need to file a warranty claim.
- 7.5.1 Contact HY-CLOR for all warranty repairs [help@hyclor.com.au](mailto:help@hyclor.com.au) or Australia: 1800 625 123  
New Zealand: (09) 9732 2477

---

## PRODUCT HELPLINE

**Australia: 1800 625 123**  
**New Zealand: (09) 973 2477**



## 8.0 PUMP SPECIFICATIONS

### HY-CLOR 0.75 HP POOL PUMP

Model number	FOBPP075 (SPS3 600)
Horsepower	0.75 HP
Max Flow Rate	285L/min
Head (m) Min/Max :	2 /10m
Max Input Power (Watt)	624
Output Power (Watt)	366
Recommended pool size	30,000 Lt
Max pool size	50,000 Lt
Filter size Requirements	21" Sand Filter (I/N: 0631611) 50 sqf Cartridge filters (I/N: 0327237)
Max water temp	35
Motor rating	IPX5
Warranty	2 years
Noise	63 dBA
Plumbing suitability	40mm pressure PVC pipe

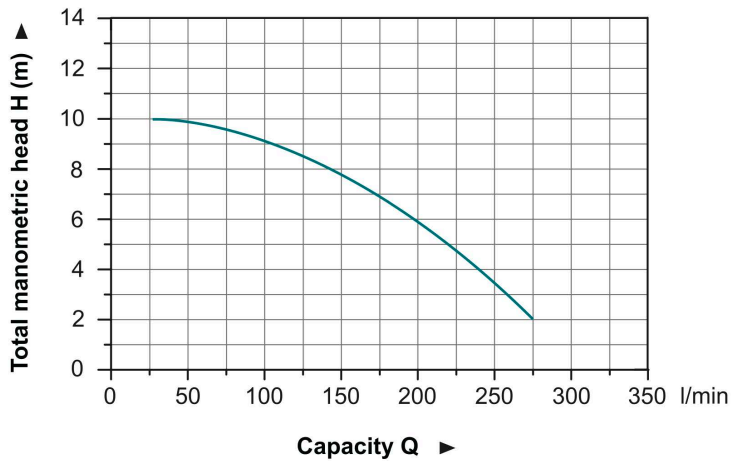

### PRODUCT HELPLINE

Australia: 1800 625 123  
New Zealand: (09) 973 2477

10

help@hyclor.com.au  
www.hyclor.com.au



## 8.0 PUMP SPECIFICATIONS

### HY-CLOR 1.0HP POOL PUMP

Model number	FOBPP10 (Type: 72543)
Horsepower	1HP
Max Flow Rate	300 L/min
Flow Rate at 9m Head	183 L/min
Head (m) Min/Max :	3 / 13m
Max Input Power (Watt)	1000
Output Power (Watt)	700
Recommended pool size	45,000L
Max pool size	70,000L
Filter size Requirements	25" Sand (I/N: 0631614) 75 sqf Cartridge filters (I/N:0327238)
Max water temp	35
Motor rating	IPX5
Warranty	2 years
Noise	71 dBA
Plumbing suitability	40mm pressure PVC pipe

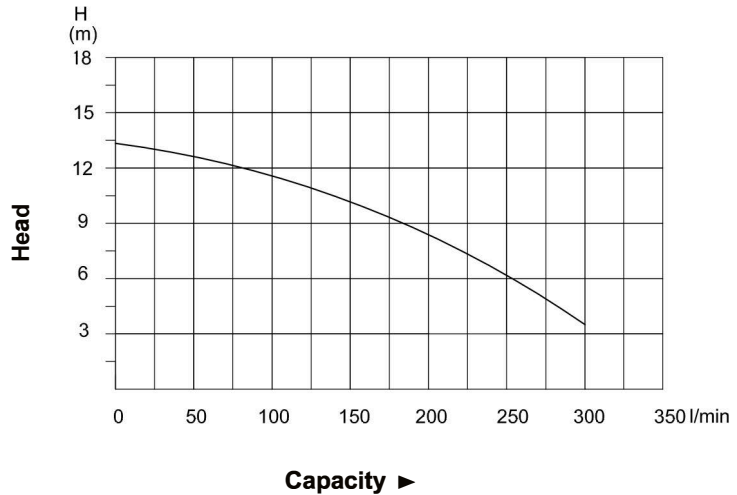

### PRODUCT HELPLINE

Australia: 1800 625 123  
New Zealand: (09) 973 2477



## HY-CLOR 1.5HP POOL PUMP

Model number	FOBPP150 (Type: 72544)
Horsepower	1.5HP
Max Flow Rate	358L/min
Flow Rate at 9m Head	238 L/min
Head (m) Min/Max :	3 / 14.5 m
Max Input Power (Watt)	1400
Output Power (Watt)	970
Recommended pool size	60,000L
Max pool size	90,000L
Filter size Requirements	28" Sand (I/N: 0631615) 100 sqf Cartridge filters (I/N:0327239)
Max water temp	35
Motor rating	IPX5
Warranty	2 years
Noise	73 dBA
Plumbing suitability	40mm pressure PVC pipe

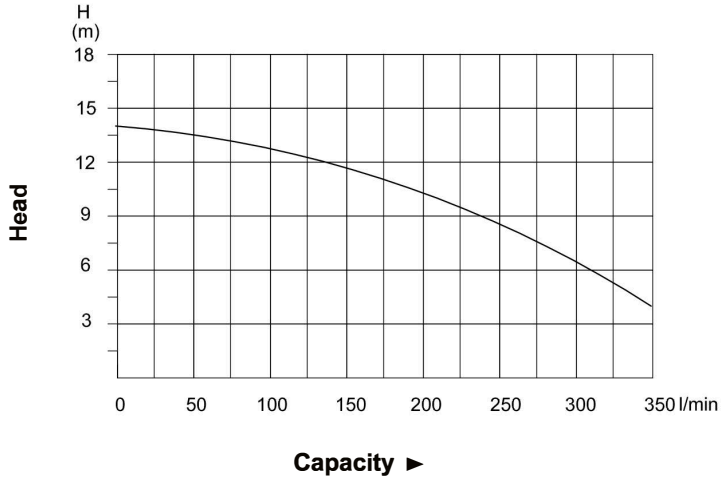

### PRODUCT HELPLINE

Australia: 1800 625 123  
New Zealand: (09) 973 2477

12

help@hyclor.com.au  
www.hyclor.com.au

**0.75HP pump : SPS125 (SPS3 600) POOL PUMP**

Drawing number	SKU	NAME	notes
1	SPS125W	SPS3-600 - WRENCH (sps125)	
2,3,5	SP-SPS3-600-LID	SPS3-600 - LID KIT (sps125)	
4	SPS125BK	SPS3-600 - BASKET (sps125)	
7,8,9	SP-SPS3-600-UNION	SPS3-600 - UNION KIT 40mm	tail, nut, oring x1
14	SPS125DS	SPS3-600 - DIFFUSER SEAL (sps125)	
15	SPS125D	SPS3-600 - DIFFUSER (sps125)	
16	SPS125IM	SPS3-600 - IMPELLER (sps125)	
17	SPS125MS	SPS3-600 - MECHANICAL SEAL (sps125)	
20	SPS125BG	SPS3-600 - BODY GASKET (sps125)	
25	SPS125WS	SPS3-600 - WATER SEAL (sps125)	
32	SPS125C12UF	SPS3-600 - CAPACITOR 12UF (sps125)	wires

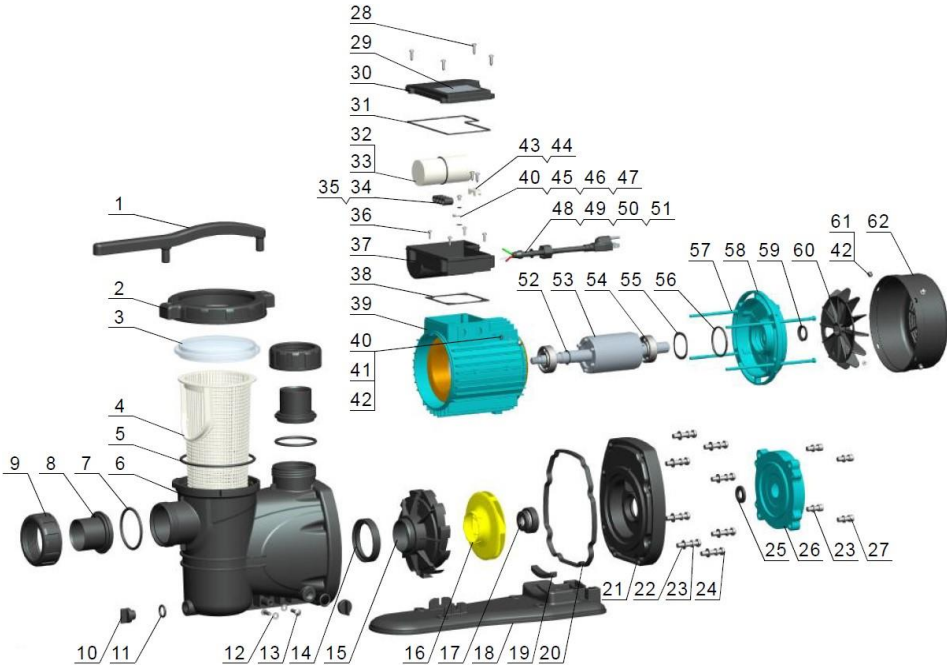

**PRODUCT HELPLINE**

Australia: 1800 625 123  
 New Zealand: (09) 973 2477



**1.0HP pump: FOBPP10 (Type 72543) POOL PUMP +  
1.5HP pump: FOBPP150 (Type 72544) POOL PUMP**

Drawing number	SKU	NAME
1,2	<i>SP-P-LIDKIT01</i>	P SERIES - LID KIT (72543/44/33)
3	<i>SPBK01</i>	P SERIES - PUMP BASKET (72543/44/33)
5	<i>SPDR01</i>	P SERIES - DIFFUSER O-RING SUIT (72543/44/33)
6	<i>SPD4</i>	P100/150 - DIFFUSER (72543/44)
7 (b)	<i>SPIM43</i>	P100 - IMPELLER (72543)
7 (c)	<i>SPIM44</i>	P150 - IMPELLER (72544)
8	<i>SPBR4</i>	P100/150 - BODY O-RING (72543/44)
12	<i>SPMS4</i>	P100/150 - MECHANICAL SEAL (72543/44)
n/a	<i>SPC30UP</i>	P100/150 - CAPACITOR 30UF
n/a	<i>SPUS4</i>	P100/150 - UNION SET (3 IN 1) 40mm
	<i>SPUS4-KIT</i>	P100/150 - UNION SET 40mm (TWO SETS)

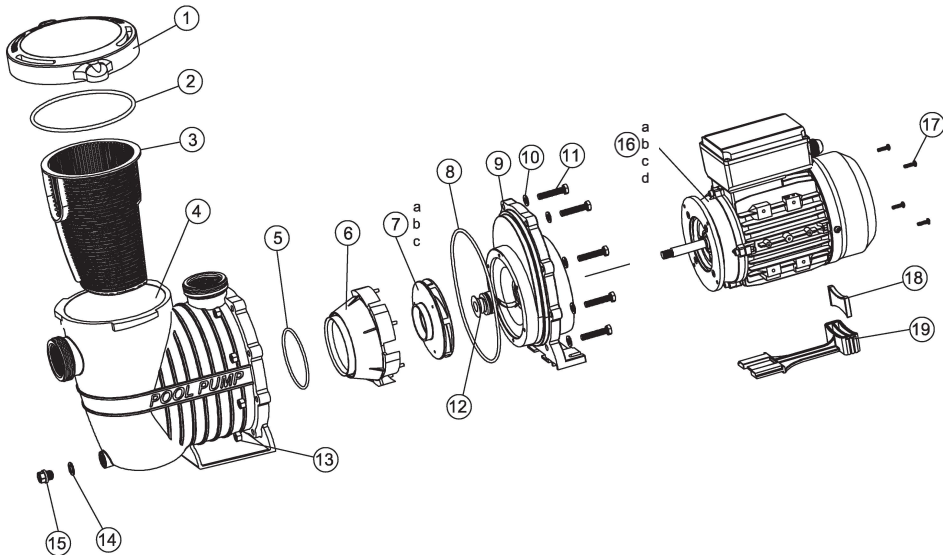

**PRODUCT HELPLINE**

Australia: 1800 625 123  
New Zealand: (09) 973 2477







**HY-CLOR AUSTRALIA PTY LTD**  
**ABN: 81 000655 381**

**178 Power Street**  
**Glendenning, NSW 2761 Australia**

**Australia: 1800 625 123**  
**New Zealand: (09) 973 2477**

**[help@hyclor.com.au](mailto:help@hyclor.com.au)**  
**[www.hyclor.com.au](http://www.hyclor.com.au)**