

RYOBI[®]

RRS1200

ORIGINAL INSTRUCTIONS

Reciprocating Saw



Important!

It is essential that you read the instructions in this manual before assembling, operating, and maintaining the product.

Subject to technical modification.

Safety, performance, and dependability have been given top priority in the design of your reciprocating saw.

INTENDED USE

The reciprocating saw is intended to be used only by adults who have read and understood the instructions and warnings in this manual and can be considered responsible for their actions. With appropriate blades fitted, the reciprocating saw is designed to cut wood, plastic, drywall and metal up to the depth described in the specification table. The reciprocating saw is designed for handheld use; it is not to be mounted onto a workbench unless specific instructions are given about how to do this by the manufacturer of the product.

GENERAL POWER TOOL SAFETY WARNINGS

WARNING

Read all safety warnings and all instructions. Failure to follow the warnings and instructions may result in electric shock, fire and/or serious injury.

Save all warnings and instructions for future reference.

The term “power tool” in the warnings refers to your mains-operated (corded) power tool or battery-operated (cordless) power tool.

1. WORK AREA SAFETY

- a. **Keep work area clean and well lit.** Cluttered or dark areas invite accidents.
- b. **Do not operate power tools in explosive atmospheres, such as in the presence of flammable liquids, gases or dust.** Power tools create sparks which may ignite the dust or fumes.
- c. **Keep children and bystanders away while operating a power tool.** Distractions can cause you to lose control.

2. ELECTRICAL SAFETY

- a. **Power tool plugs must match the outlet. Never modify the plug in any way. Do not use any adaptor plugs with earthed (grounded) power tools.** Unmodified plugs and matching outlets will reduce risk of electric shock.
- b. **Avoid body contact with earthed or grounded surfaces, such as pipes, radiators, ranges and refrigerators.** There is an increased risk of electric shock if your body is earthed or grounded.
- c. **Do not expose power tools to rain or wet conditions.** Water entering a power tool will increase the risk of electric shock.
- d. **Do not abuse the cord. Never use the cord for carrying, pulling or unplugging the power tool. Keep cord away from heat, oil, sharp edges or moving parts.** Damaged or entangled cords increase the risk of electric shock.
- e. **When operating a power tool outdoors, use an extension cord suitable for outdoor use.** Use of a cord suitable for outdoor use reduces the risk of

electric shock.

- f. **If operating power tools in a damp location is unavoidable, use a residual current device (RCD) protected supply.** Use of an RCD reduces the risk of electric shock.

3. PERSONAL SAFETY

- a. **Stay alert, watch what you are doing and use common sense when operating a power tool. Do not use a power tool while you are tired or under the influence of drugs, alcohol or medication.** A moment of inattention while operating power tools may result in serious personal injury.
- b. **Use personal protective equipment. Always wear eye protection.** Protective equipment such as dust mask, non-skid safety shoes, hard hat, or hearing protection used for appropriate conditions will reduce personal injuries.
- c. **Prevent unintentional starting. Ensure the switch is in the off-position before connecting to power source and/or battery pack, picking up or carrying the tool.** Carrying power tools with your finger on the switch or energising power tools that have the switch on invites accidents.
- d. **Remove any adjusting key or wrench before turning the power tool on.** A wrench or a key left attached to a rotating part of the power tool may result in personal injury.
- e. **Do not overreach. Keep proper footing and balance at all times.** This enables better control of the power tool in unexpected situations.
- f. **Dress properly. Do not wear loose clothing or jewellery. Keep your hair, clothing and gloves away from moving parts.** Loose clothes, jewellery or long hair can be caught in moving parts.
- g. **If devices are provided for the connection of dust extraction and collection facilities, ensure these are connected and properly used.** Use of dust collection can reduce dust-related hazards.

4. POWER TOOL USE AND CARE

- a. **Do not force the power tool. Use the correct power tool for your application.** The correct power tool will do the job better and safer at the rate for which it was designed.
- b. **Do not use the power tool if the switch does not turn it on and off.** Any power tool that cannot be controlled with the switch is dangerous and must be repaired.
- c. **Disconnect the plug from the power source and/or the battery pack from the power tool before making any adjustments, changing accessories, or storing power tools.** Such preventive safety measures reduce the risk of starting the power tool accidentally.
- d. **Store idle power tools out of the reach of children and do not allow persons unfamiliar with the power tool or these instructions to operate the power tool.** Power tools are dangerous in the hands of untrained users.
- e. **Maintain power tools. Check for misalignment**

or binding of moving parts, breakage of parts and any other condition that may affect the power tool's operation. If damaged, have the power tool repaired before use. Many accidents are caused by poorly maintained power tools.

- f. **Keep cutting tools sharp and clean.** Properly maintained cutting tools with sharp cutting edges are less likely to bind and are easier to control.
- g. **Use the power tool, accessories and tool bits etc., in accordance with these instructions, taking into account the working conditions and the work to be performed.** Use of the power tool for operations different from those intended could result in a hazardous situation.

5. SERVICE

- a. **Have your power tool serviced by a qualified repair person using only identical manufacturer's replacement parts.** This will ensure that the safety of the power tool is maintained.

RECIPROCATING SAW SAFETY WARNINGS

- **Hold power tool by insulated gripping surfaces, when performing an operation where the cutting accessory may contact hidden wiring or its own cord.** Cutting accessory contacting a "live" wire may make exposed metal parts of the power tool "live" and could give the operator an electric shock.
- **Protect your lungs.** Wear a dust mask if operation is dusty.

ADDITIONAL SAFETY WARNINGS

- We recommend that the product always be supplied via a residual current device (RCD) with a rated residual current of 30 mA or less.

RESIDUAL RISKS

Even when the reciprocating saw is used as prescribed, it is still impossible to completely eliminate certain residual risk factors. The following hazards may arise and the operator should pay special attention to avoid the following:

- Injury caused by vibration
 - Use the lowest speed setting which achieves the task. Limit exposure. See risk reduction.
- Injury caused by dust
 - Wear eye protection at all times. Wear appropriate dust mask with suitable filters that can protect against particles from the material being worked on. Do not eat, drink, or smoke in the work area. Ensure adequate ventilation.
- Electric shock
 - The blade may contact hidden wiring causing parts of the product to become live. Always hold the product by the designated handles and take care when blind cutting into walls and floors where cables may be hidden.

NOTE: When working on walls, ceilings, or floors, take care to avoid electric cables and gas or water pipes. The product must be operated with both hands.

- Injury from contact with the cutting blade
 - The blades are very sharp and will become hot during use. Wear gloves when changing blades. Keep hands away from the cutting area at all times. Clamp the workpiece whenever possible.
- Injury caused by noise
 - Prolonged exposure to noise will increase the risk of hearing damage, and the effects are cumulative. When using power tools for any extended period of time, wear hearing protection.

RISK REDUCTION

It has been reported that vibrations from handheld tools may contribute to a condition called Raynaud's Syndrome in certain individuals. Symptoms may include tingling, numbness and blanching of the fingers, usually apparent upon exposure to cold. Hereditary factors, exposure to cold and dampness, diet, smoking, and work practices are all thought to contribute to the development of these symptoms. There are measures that can be taken by the operator to possibly reduce the effects of vibration:

- Keep your body warm in cold weather. When operating the product, wear gloves to keep the hands and wrists warm. It is reported that cold weather is a major factor contributing to Raynaud's Syndrome.
- After each period of operation, exercise to increase blood circulation.
- Take frequent work breaks. Limit the amount of exposure per day.

If you experience any of the symptoms of this condition, immediately discontinue use and see your doctor about these symptoms.

⚠ WARNING

Injuries may be caused or aggravated by prolonged use of a tool. When using any tool for prolonged periods, ensure you take regular breaks.

KNOW YOUR PRODUCT

See page 6.

1. Blade
2. Shoe assembly
3. Toolless blade change system
4. Switch trigger
5. Cord retainer

OPERATION

ADJUSTING THE SHOE ASSEMBLY

- The product has a shoe assembly that pivots up and down in both directions to ensure the shoe is flat against the cutting surface at all times. The adjustable shoe also slides in and out, which allows for the use of the blade teeth at different positions on the blade.
- Push the saw blade into the saw blade holder up to the stop. Make sure that the saw blade is fixed securely.



OPERATION TIPS

You may cut metals such as sheet steel, pipe steel rods, aluminum, brass, and copper with the product.

⚠ WARNING

Be careful not to twist or bend the saw blade.

- Do not force the product.
- Use cutting oil when cutting soft metals and steel. Cutting oil also keeps the blades cool, increases cutting action, and prolongs blade life.
- Never use gasoline since normal sparking of motor could ignite fumes.
- Clamp the workpiece firmly and cut close to the clamping point to eliminate any vibration of the work. When cutting conduit pipe or angle iron, secure the workpiece with a vise, if possible, and cut close to the vise. To cut a thin-sheet material, place the material between two hardboards or plywood and clamp the layers to eliminate vibration and material tearing.
- Always keep firm pressure on the base to hold it securely against the workpiece.
- Do not use cracked or distorted saw blades. Do not use saw blades that are damaged or deformed.

⚠ WARNING

Dust from certain paints, coatings, and materials may cause irritation or allergic reactions. Dust from wood such as oak, beech, MDF, and others are carcinogenic. Materials containing asbestos should only be worked on or processed by qualified specialist operators.

⚠ WARNING

Always wear safety goggles or safety glasses with side shields when operating the product. Failure to do so could result in objects being thrown into your eyes resulting in possible serious injury.

MAINTENANCE

⚠ WARNING

The product should never be connected to a power supply when assembling parts, making adjustments, cleaning, performing maintenance, or when the product is not in use. Disconnecting the product will prevent accidental starting that could cause serious injury.

⚠ WARNING

When servicing, use only original manufacturer's replacement parts. Use of any other parts may create a hazard or cause product damage.

⚠ WARNING

For greater safety and reliability, all repairs should be performed by an authorised Ryobi service centre.

⚠ WARNING

Always wear safety goggles or safety glasses with side shields when operating the product. Failure to do so could result in objects being thrown into your eyes resulting in possible serious injury.

If the power supply cord is damaged, it must be replaced only by the manufacturer or by an authorised service centre to avoid a safety hazard. Contact authorised service centre. When changing the saw blade, ensure that the saw blade holder is free of material residue, such as wood or metal shavings.

GENERAL

Avoid using solvents when cleaning plastic parts. Most plastics are susceptible to various types of commercial solvents and may be damaged by their use. Use clean cloths to remove dirt, carbon dust, etc.

⚠ WARNING

Do not, at any time, let brake fluids, gasoline, petroleum-based products, and penetrating oils, come in contact with plastic parts. They contain chemicals that can damage, weaken, or destroy plastic.

Electrical tools used on fiberglass material, wallboard, spackling compounds, or plaster are subject to accelerated wear and possible premature failure because the fiberglass chips and grindings are highly abrasive to bearings, brushes, and commutators. We do not recommend using the product for extended periods of time on these types of materials.

⚠ WARNING

Do not use compressed air to blow dust from the product. This practice is dangerous and can cause dirt and grit to be blasted into someone's eyes, causing injury.

LUBRICATION

All of the bearings in the product are lubricated with a sufficient amount of high grade lubricant for the life span of the product under normal operating conditions. Therefore, no further lubrication is required.

ENVIRONMENTAL PROTECTION



Recycle raw materials instead of disposing of as waste. The machine, accessories, and packaging should be sorted for environment-friendly recycling.



SYMBOLS ON THE PRODUCT



Safety Alert

V Volts

Hz Hertz

~ Alternating current

W Watts

n_0 No-load speed

min^{-1} Revolutions or reciprocations per minute



Regulatory Compliance Mark (RCM). Product meets applicable regulatory requirements.



Class II tool
Double insulation



Please read the instructions carefully before starting the product.



Waste electrical products should not be disposed of with household waste. Please recycle where facilities exist. Check with your local authority or retailer for recycling advice.



Wear non-slip, heavy duty gloves



Note



Warning

The following signal words and meanings are intended to explain the levels of risk associated with this product:

DANGER

Indicates an imminently hazardous situation, which, if not avoided, will result in death or serious injury.

WARNING

Indicates a potentially hazardous situation, which, if not avoided, could result in death or serious injury.

CAUTION

Indicates a potentially hazardous situation, which, if not avoided, may result in minor or moderate injury.

CAUTION

(Without Safety Alert Symbol) Indicates a situation that may result in property damage.

SYMBOLS IN THIS MANUAL



Connect to the power supply.



Disconnect from the power supply.



Parts or accessories sold separately



Waste electrical products should not be disposed of with household waste. Please recycle where facilities exist.



Speed, minimum



Speed, maximum



Wood



Plastic



Metal



DANGER: Sharp blade

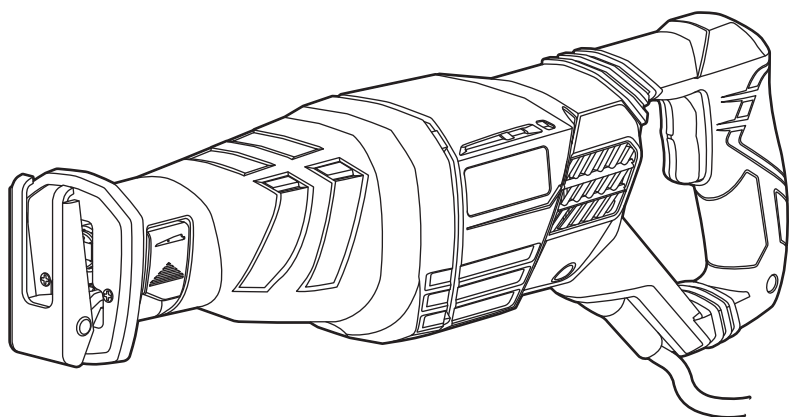

x 1

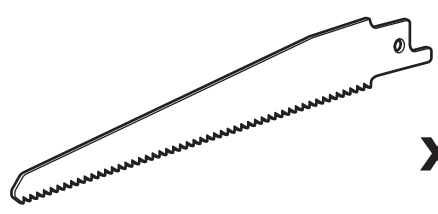

x 1



x 1

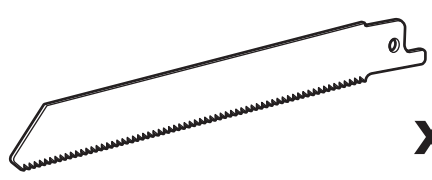

x 1



x 1

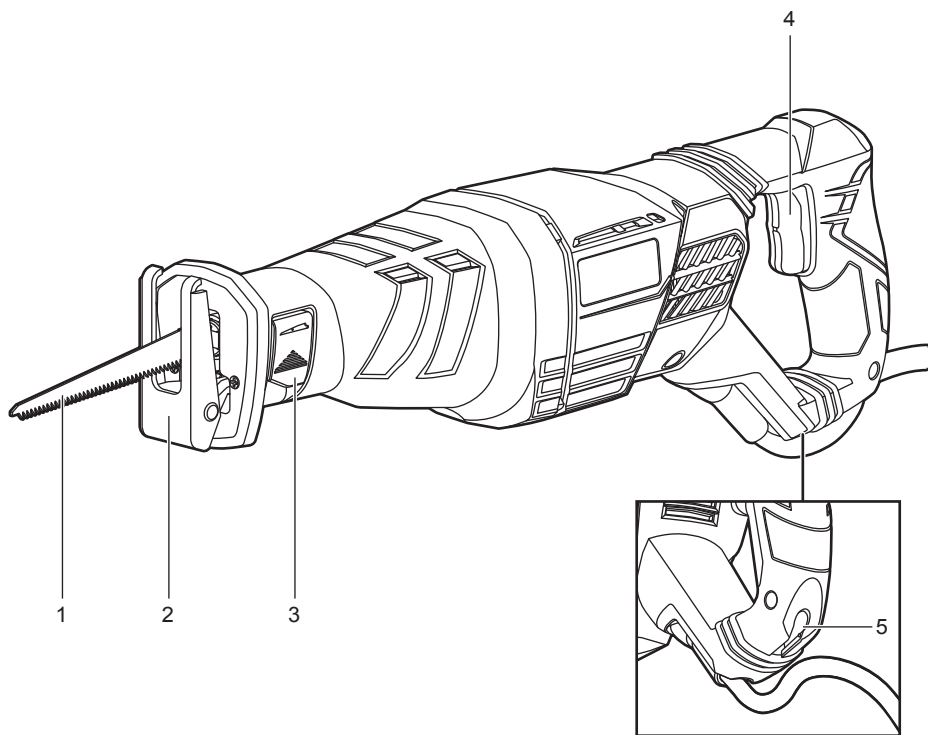

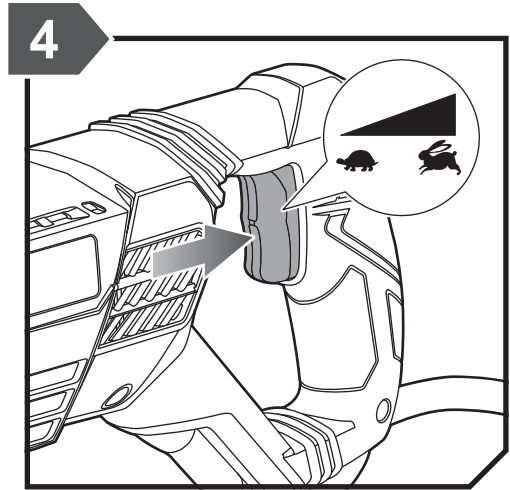
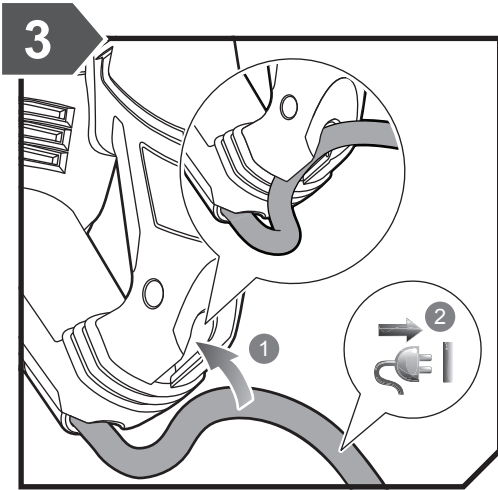
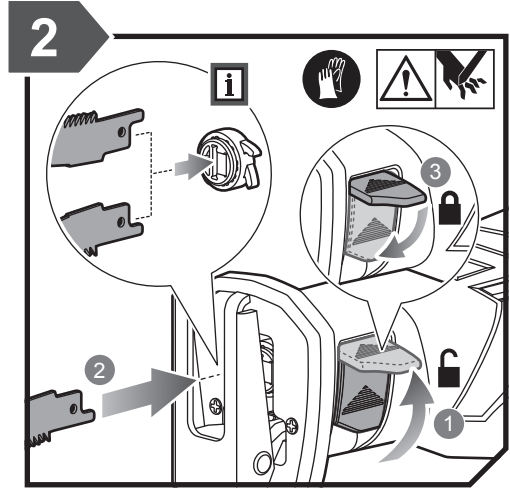
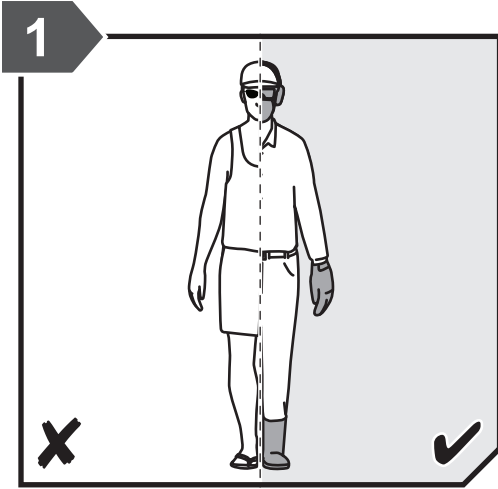

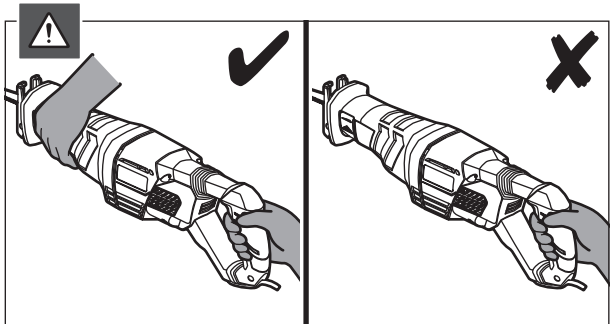
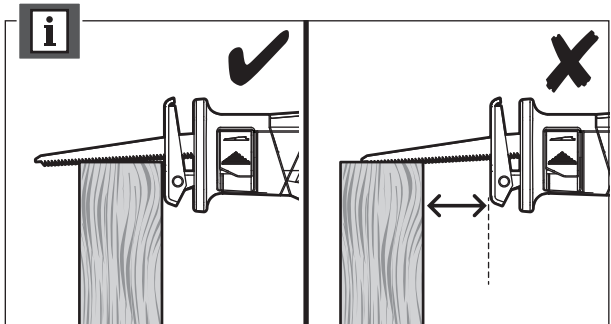
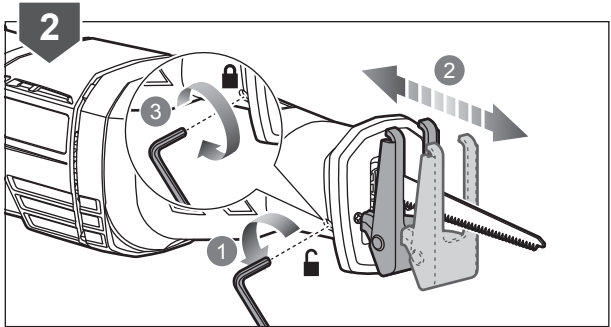
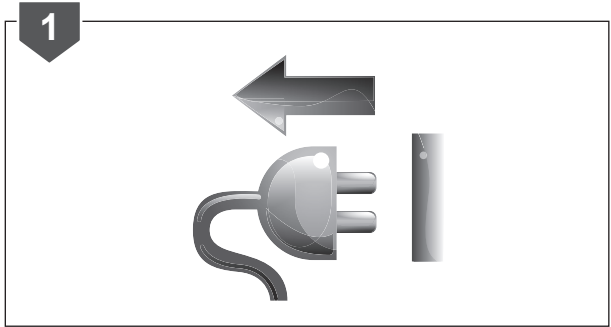
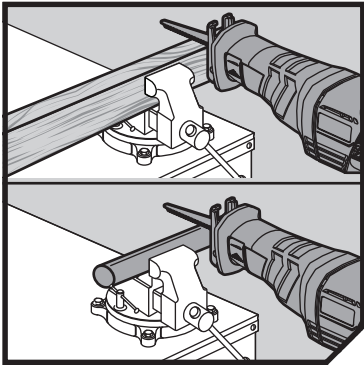

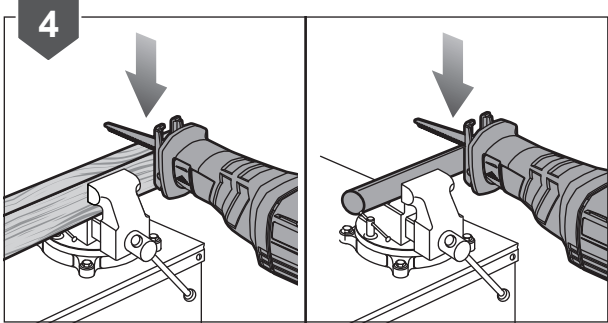
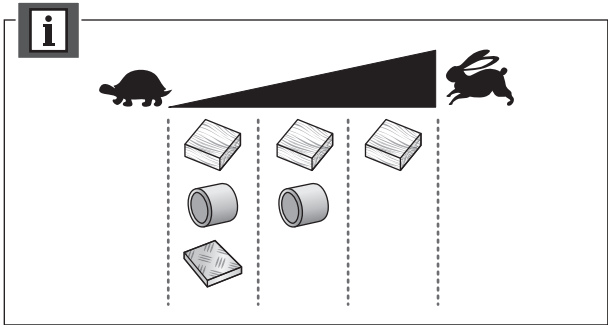
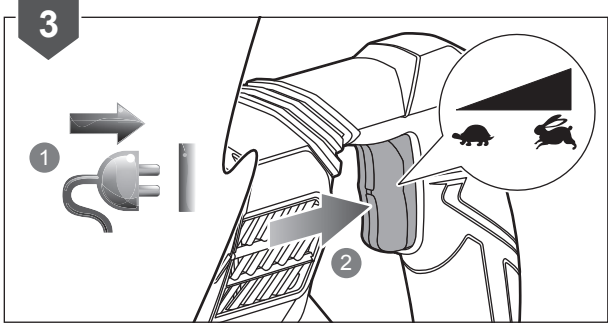

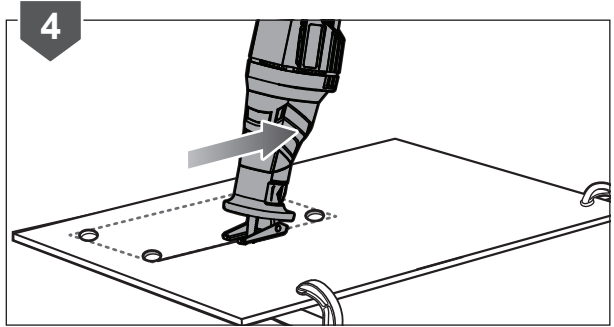
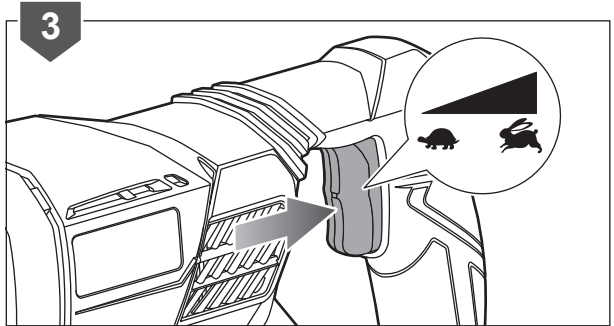
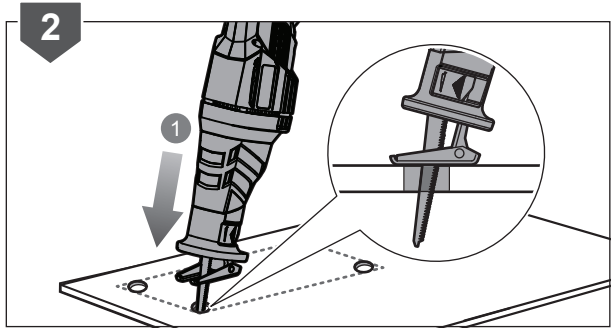
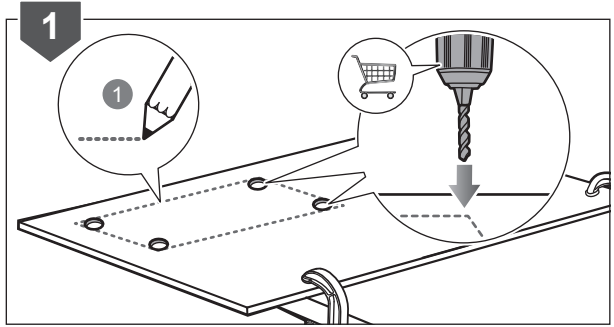
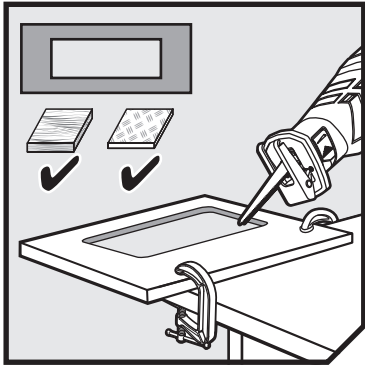

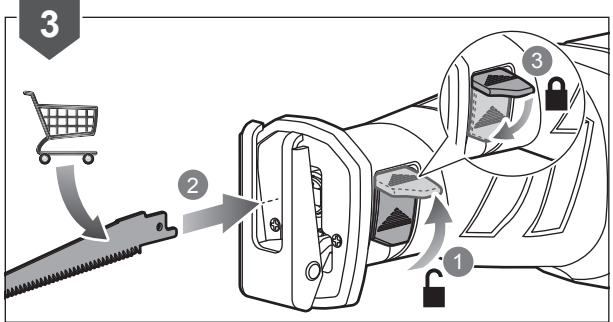
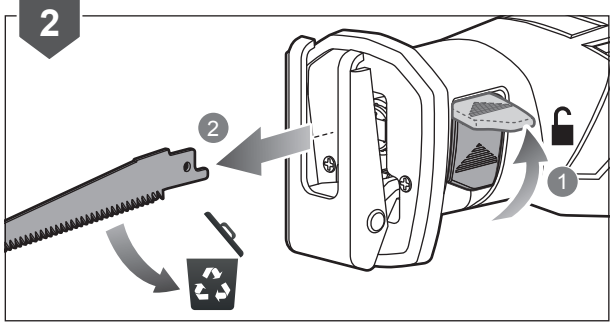
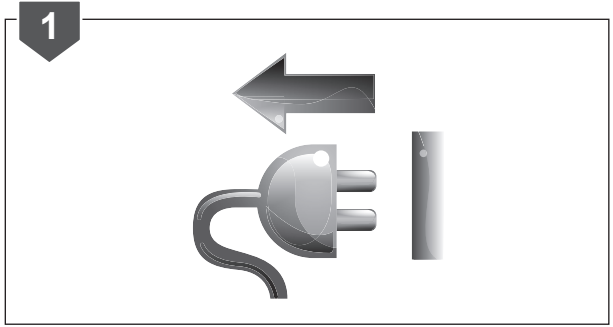
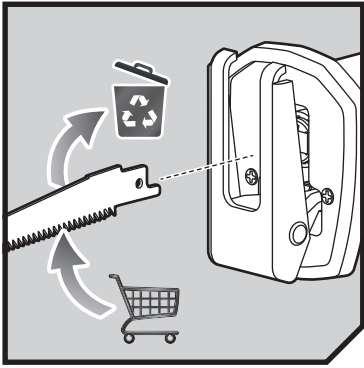

PRODUCT SPECIFICATIONS

Reciprocating saw

Model	RRS1200
Rated voltage	220 - 240 V ~ 50 Hz
Input	1200 W
Strokes per minute	0 - 3,000 min ⁻¹
Length of stroke	30 mm (1-3/16")
Cutting capacity (Wood)	200 mm
Cutting capacity (Steel)	20 mm
Weight	3.3 kg





Imported by:

Techtronic Industries (Australia) Pty. Ltd.
31 Gilby Road,
Mt Waverley, VIC 3149, Australia

Techtronic Industries New Zealand Ltd.
2 Landing Drive, Auckland Airport,
Mangere, New Zealand 2022