



MATADOR™



PATIO STAND

Stand for Tempo 1 Burner Portable BBQ
Model: BG323-1B Stand

Retain manual for future reference.



CONTENTS

FEATURES	3
IMPORTANT SAFETY WARNINGS	4
IMPORTANT SAFETY INSTRUCTIONS	5
EXPLODED PARTS VIEW	7
PARTS LIST	8
BOLT PACK	9
ASSEMBLY STEPS	10
BBQ LOCATION – OUTDOOR AREA	15
CARE AND MAINTENANCE	18
WARRANTY	19



FEATURES

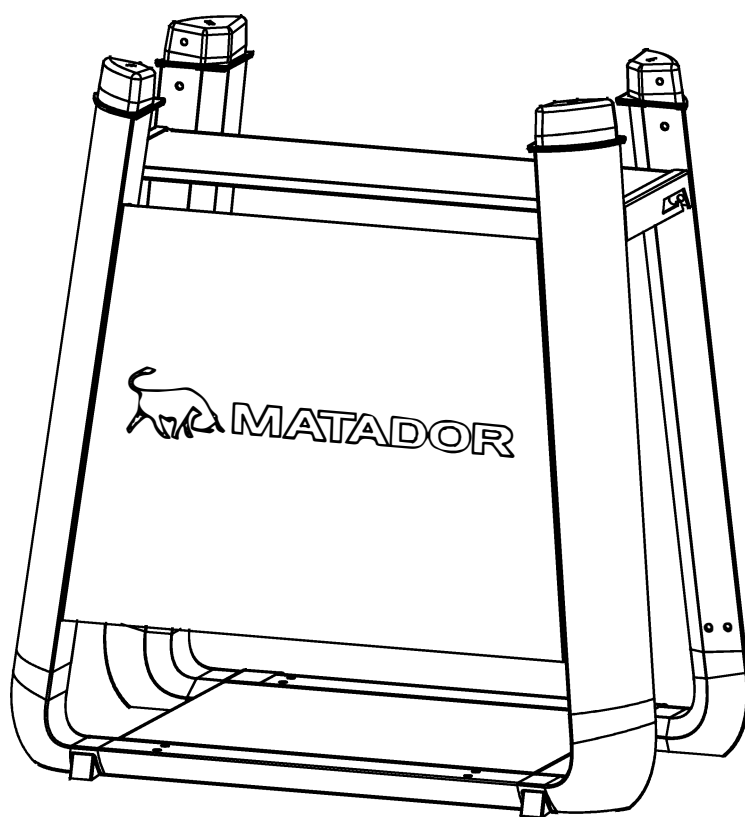

Overall Patio Stand Dimensions

1B	Length	Height	Depth
Freestanding	550	700	550

BBQ PATIO STAND ASSEMBLY & OPERATION INSTRUCTIONS

1 Patio Stand – MODEL BG323-1B PATIO STAND

Important! Please read these instructions carefully before use!

FOR OUTDOOR USE ONLY

IF YOU SMELL GAS:

1. Shut off gas to the BBQ at the cylinder.
2. Open hood.
3. Extinguish any flames.
4. If odour continues, immediately call your gas supplier.

FOR YOUR SAFETY

1. Do not store or use gasoline or other flammable vapors or liquids in the vicinity of this or any other appliance.
2. An LPG cylinder not connected for use shall not be stored in the vicinity of this or any other appliance.

- This stand complies with Australian standards when used with Matador Tempo model BG323-1B BBQ. It is not intended for use with any other model BBQs.
- Improper installation, adjustment, alteration, service or maintenance can cause property damage, injury or death. Read the installation, operating and maintenance instructions thoroughly before installing or servicing this equipment.
- Warning: accessible parts may be very hot. Keep young children away.
- Do not move the appliance during use.
- Turn off the gas supply at the gas cylinder after use.
- Any modification of the appliance may be dangerous.
- Installer to leave instructions with the consumer and consumer to retain them for future reference.
- Do not replace the grill with an extra hotplate. The warranty will be void and it violates the gas approval, the grill provides the ventilation needed for the BBQ to operate safely. It is not designed to be a solid hotplate device.
- Please ensure all packaging and transit protection materials are removed prior to using the BBQ.



DO NOT OPERATE THIS APPLIANCE BEFORE READING THE INSTRUCTION BOOKLET

DO NOT PLACE ARTICLES ON OR AGAINST THIS APPLIANCE

DO NOT STORE CHEMICALS OR FLAMMABLE MATERIALS OR SPRAY AEROSOLS NEAR THIS APPLIANCE

DO NOT OPERATE THIS APPLIANCE INDOORS

DO NOT ENCLOSE THIS APPLIANCE

DO NOT LIGHT OR OPERATE WITH COVER ON



IMPORTANT SAFETY INSTRUCTIONS

1. **This BBQ PATIO STAND is an OUTDOOR APPLIANCE ONLY. It should NOT be used indoors.**
2. READ ALL OPERATING INSTRUCTION BEFORE LIGHTING.
3. Do not perform any servicing on the BBQ yourself. This includes internal adjustment of the regulator and gas valves. Servicing can only be carried out by authorised technicians.
4. When cylinder is replaced or reconnected, check for leaks.
5. Do not store chemicals or flammable materials near this appliance.
6. People with flammable clothing such as nylon etc. should keep well away from the BBQ when it is operating.
7. Do not leave food unattended on the BBQ.
8. In case of a fat fire, immediately turn the LPG cylinder valve off.
9. Particular care must be taken when removing drip tray. Hot fat can cause serious injury.
10. This BBQ should not be located under overhead combustible construction and proper clearances must be maintained at all times from combustible construction and/or materials, with **MINIMUM** clearances as follows:
 - From Sides 200 mm
 - From Back 300 mm
 - Overhead 1000 mm
11. Never leave burners on high for more than 10 minutes unless actually cooking. If the burner makes a hissing or roaring sound when lit, it may be burning internally. Turn burner off, allow it to cool and light it again.
12. Do not delay ignition after opening the gas valve, this will result in a buildup of unburned gas.
13. Never use your BBQ in a garage, porch, shed, breezeway or any other enclosed area. Your BBQ should not be placed under any surface that will burn.
14. Do not obstruct the flow of ventilation air around the BBQ.
15. This BBQ is not intended to be installed in or on recreational vehicles and/or boats.
16. Remove promotional stickers (where fitted) from hood before use.

IMPORTANT

This appliance shall only be used in an above ground open-air situation with natural ventilation, without stagnant areas, where gas leakage and products of combustion are rapidly dispersed by wind and natural convection.

WARNING

A strong gas smell or the hissing sound of gas indicates a serious problem with your BBQ or the LPG gas cylinder. Failure to immediately follow the steps listed below could cause serious bodily injury, death, or property damage.

1. Shut off gas supply to the BBQ.
2. Turn the control knobs to OFF position.
3. Put out any flame with a class B fire extinguisher and clear the area of people.
4. Open BBQ hood.
5. Move away from the LPG gas cylinder.

Do not try to fix the problem yourself unless you are competent.

If odour continues or you have a fire you cannot extinguish, call your fire department immediately.





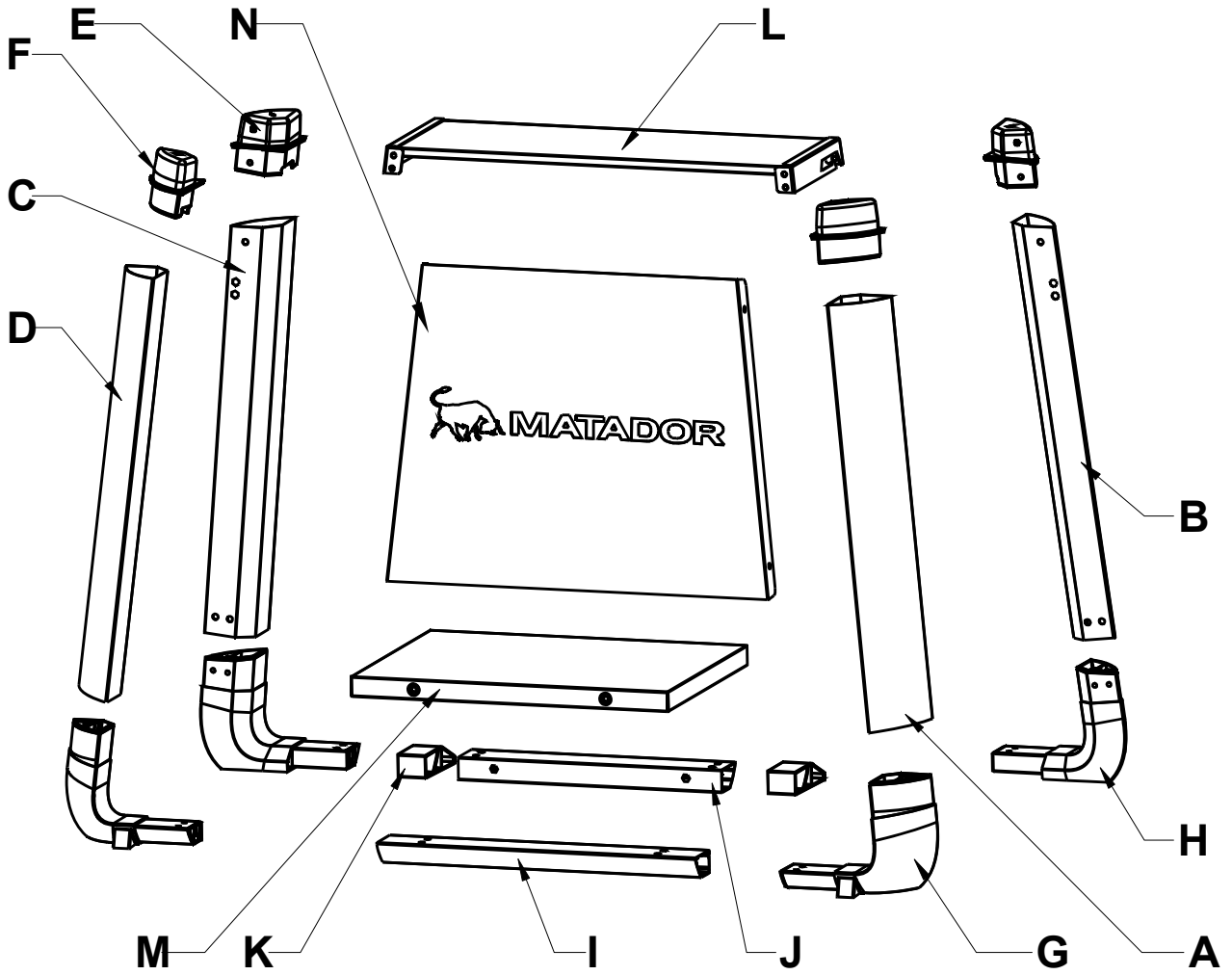

NOTE: The normal flow of gas through the Regulator and Hose Assembly can create a humming sound. A low volume of sound is perfectly normal and will not interfere with operation of the BBQ. If humming sound is loud and excessive you may need to purge air from the gas line.



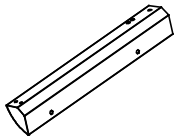

EXPLODED PARTS VIEW

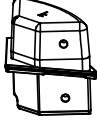
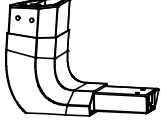

PARTS LIST

POS	Picture	Part Name	QTY
A		Leg – right front	1
B		Leg – right rear	1
C		Leg – left rear	1
D		Leg – left front	1
E		Leg cap E	2
F		Leg cap F	2
G		Corner G	2
H		Corner H	2
I		Front crossbeam	1

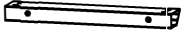
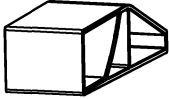
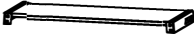
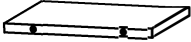

J		Rear Crossbeam	1
K		Rear Foot	2
L		Storage shelf	1
M		Base	1
N		Front panel	1

BOLT PACK

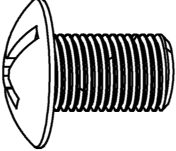
POS	Picture	Part Name	QTY
AA		M6x12 Screw	40

ASSEMBLY STEPS

Remove all packaging and transit protection materials from parts before assembly.
Wear gloves during assembly to protect your hands from cuts and abrasions.
Some stages of assembly may require a 2 people to complete safely.
To assemble this Trolley you will need a Phillips head screwdriver (not provided with the BBQ).

Step 1.

Assemble Corner's (G&H) to the 'Front Crossbeam' (I) using Screw (AA) 4pcs

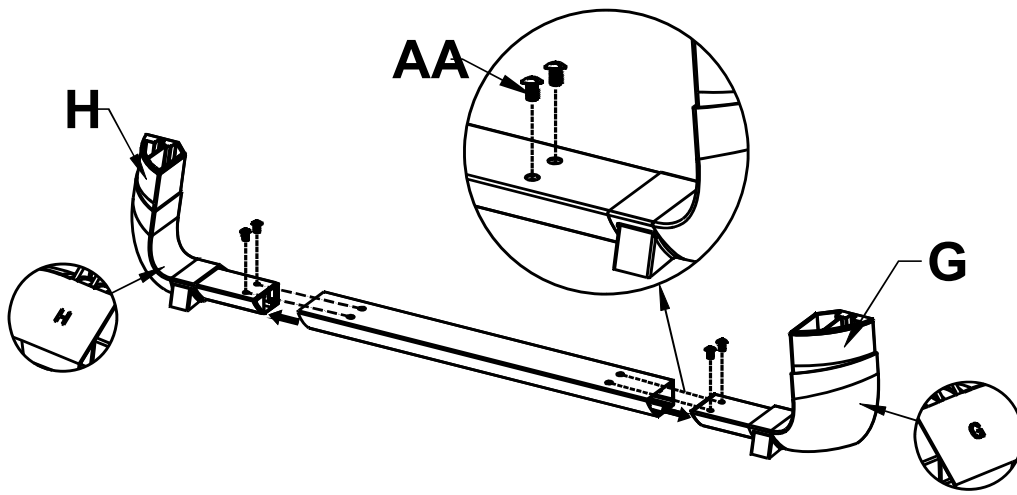

Step 2.

Insert Corner's (G&H) to the 'Rear Crossbeam' (J) using Screw (AA) 4pcs

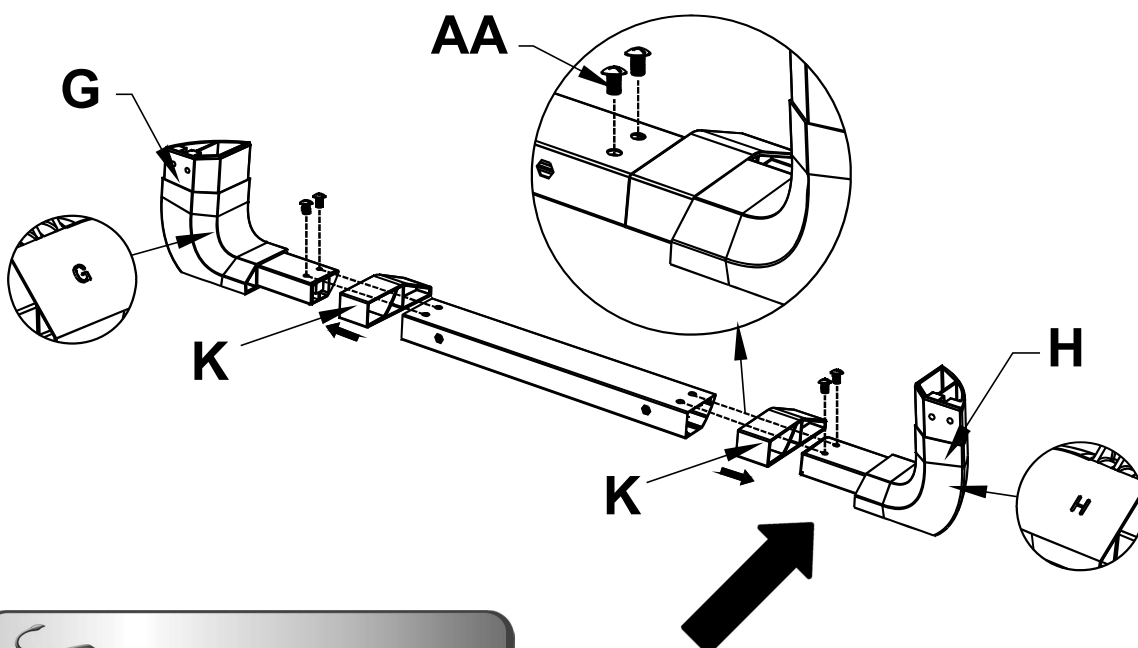

IMPORTANT ORIENTATION

Step 3.

Assemble the 'Base' (M) to the Crossbeam assemblies using Screw (AA) 4pcs

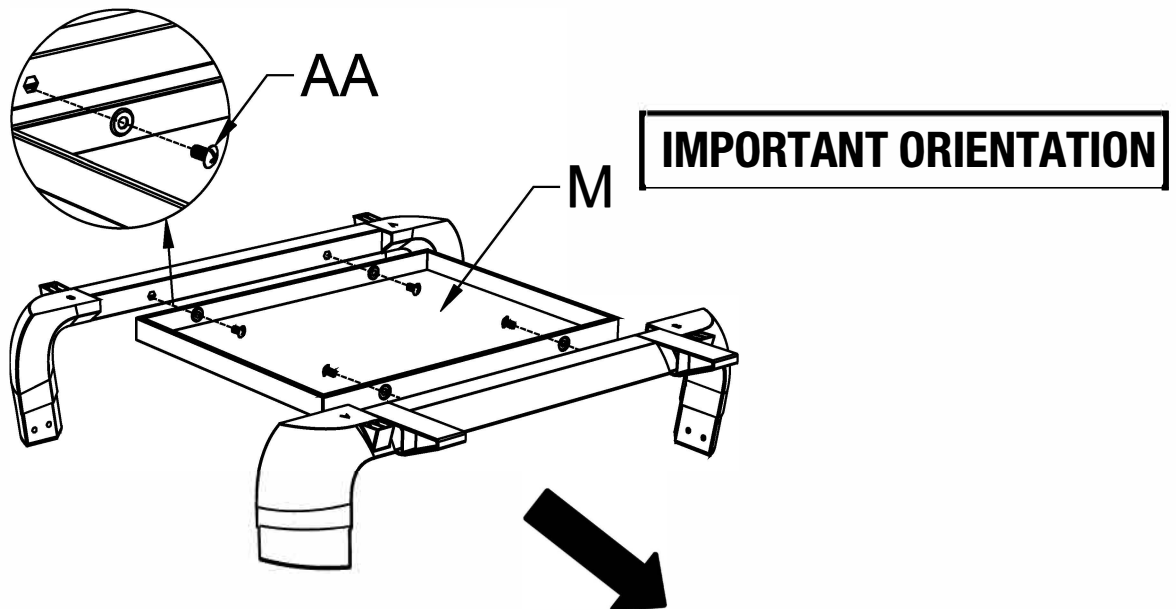

Step 4.

Assemble Legs 'A', 'B', 'C' and 'D' to the Base assembly using Screw (AA) 8pcs

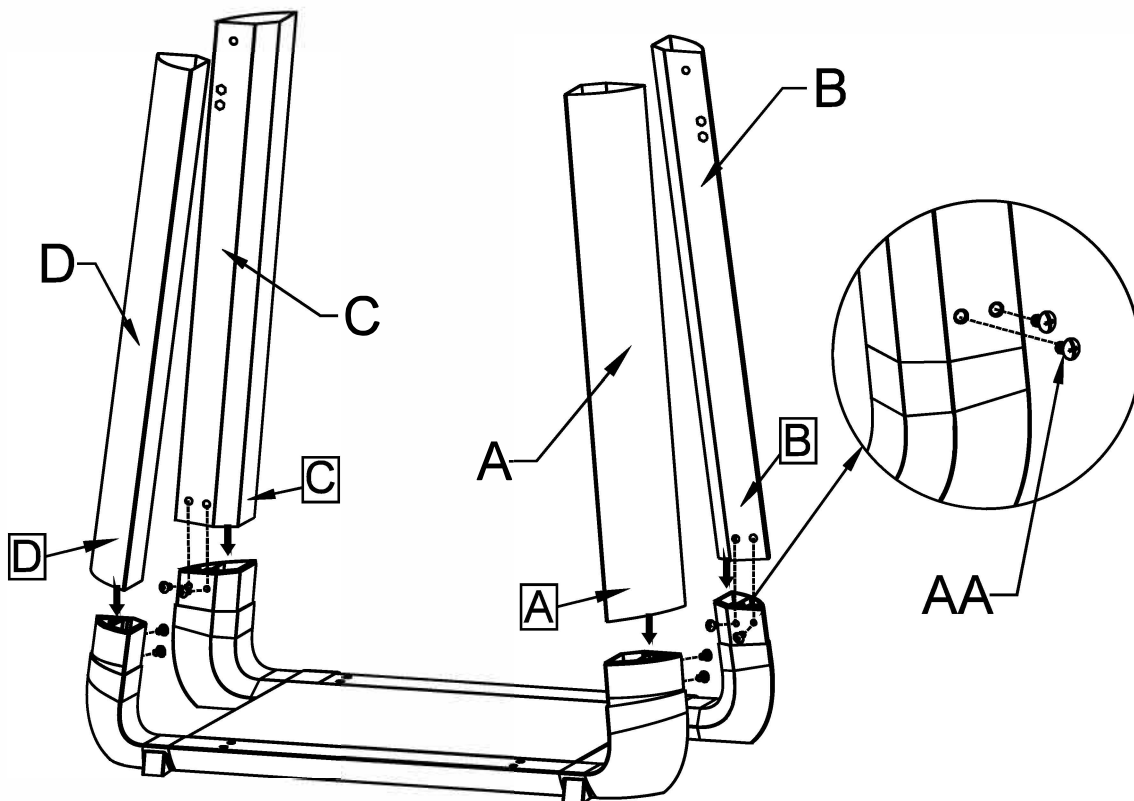

Step 5.

Assemble the 4 'Leg caps' (E&F) to the top of the legs, using Screw (AA) 4pcs

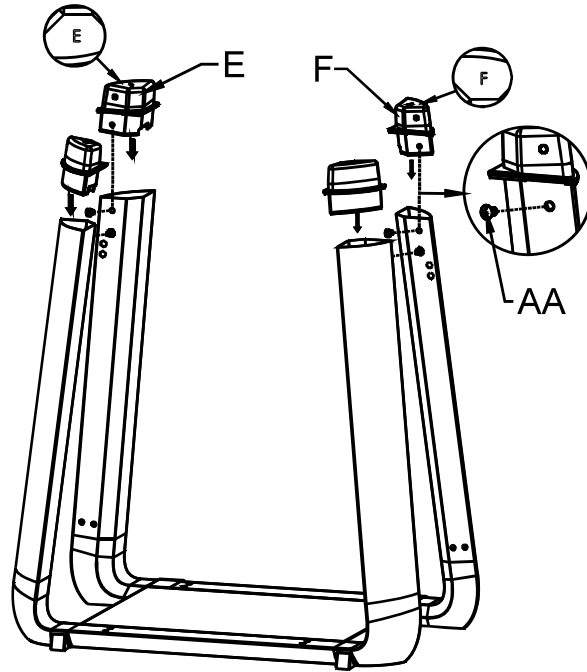

Step 6.

Assemble the 'Storage shelf' (L) to legs using Screw (AA) 8pcs

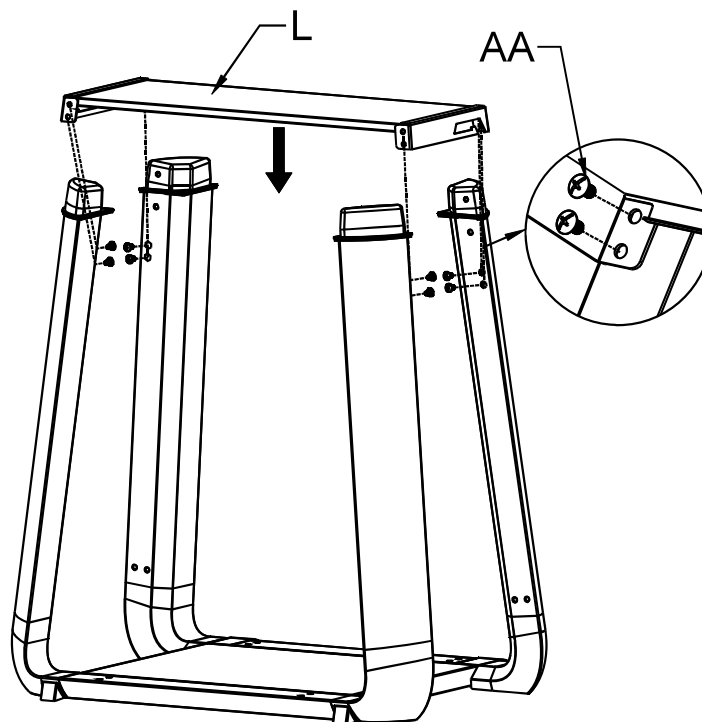

Step 7.

Assemble the 'Front panel' (N) to the Stand using Screw (AA) 4pcs

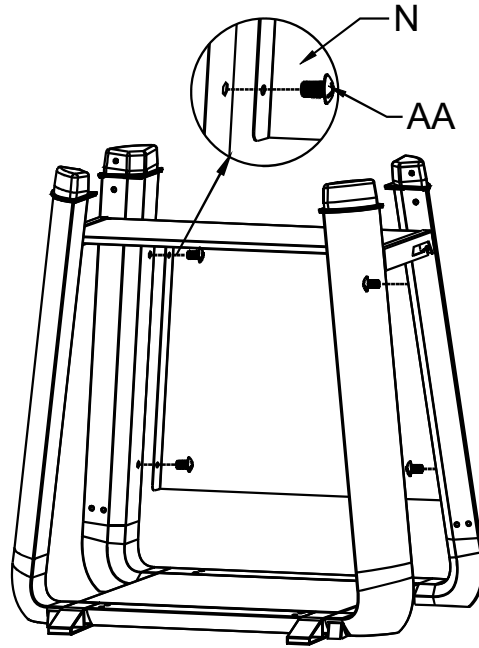

FULLY ASSEMBLED STAND

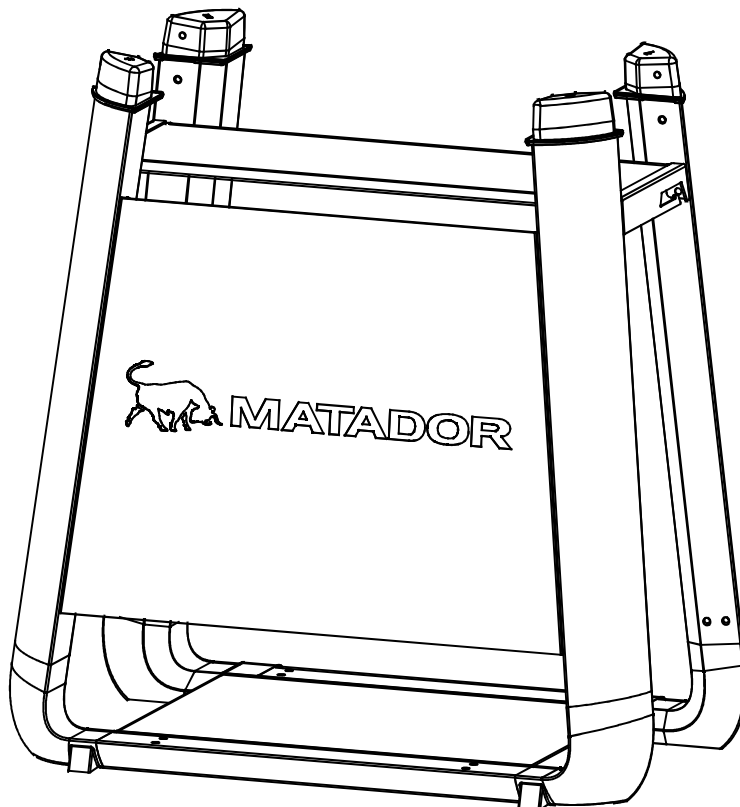

Assemble the BBQ to the Patio Stand using Screw (AA)
4pcs.

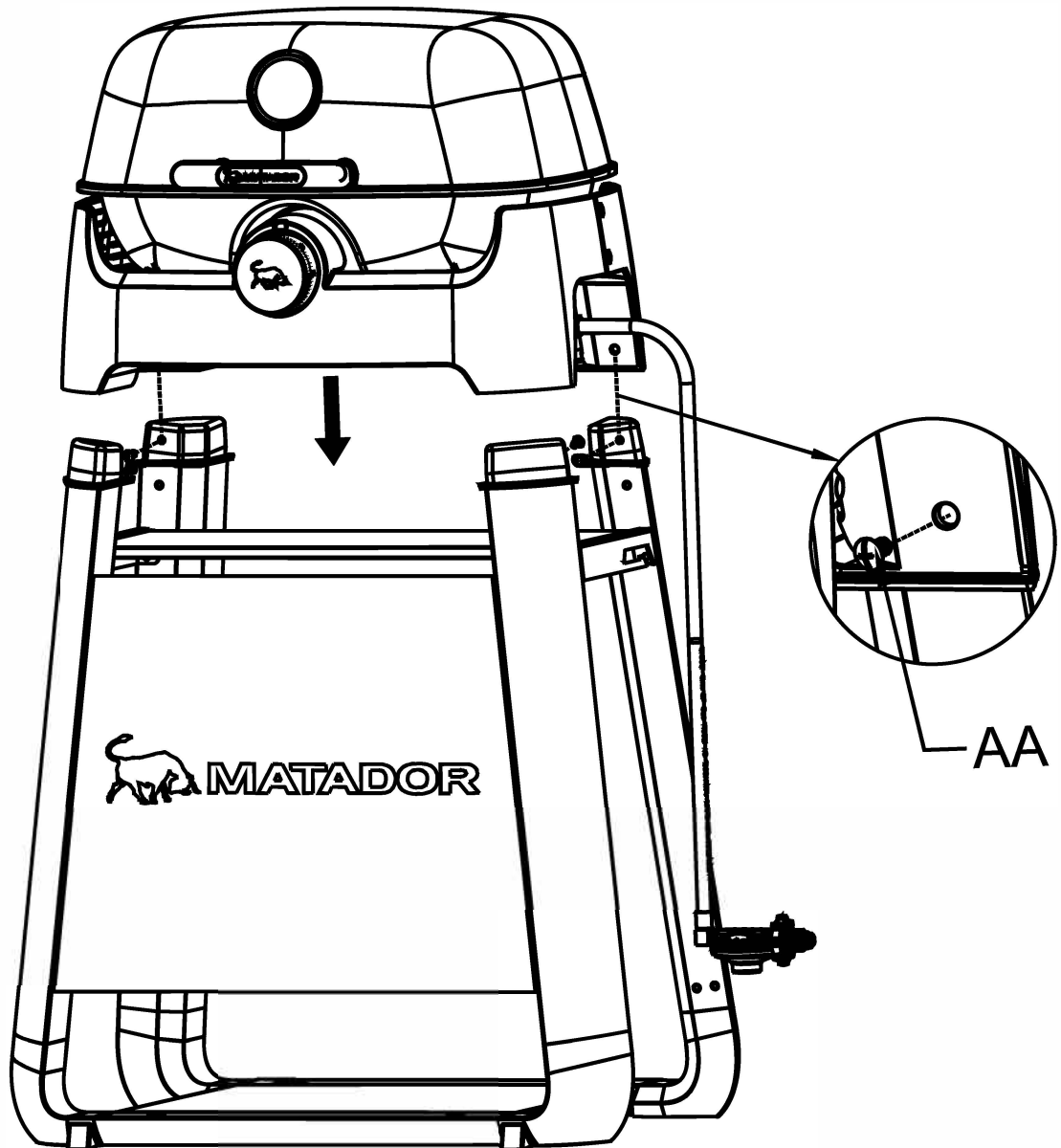

BBQ LOCATION - OUTDOOR AREAS

This appliance shall only be used in an above ground open-air situation with natural ventilation, without stagnant areas, where gas leakage and products of combustion are rapidly dispersed by wind and natural convection.

Any enclosure in which the appliance is installed or used shall comply with one of the following:

An enclosure with walls on all sides, but at least one permanent opening at ground level and no overhead cover.

Within a partial enclosure that includes an overhead cover and no more than two walls.

Within a partial enclosure that includes an overhead cover and more than two walls, the following shall apply:

At least 25% of the total wall area is completely open; and
At least 30% of the remaining wall area is open and unrestricted.

In the case of balconies, at least 20% of the total of the side, back and front wall areas shall be and remain open and unrestricted.

Examples of the correct appliance outdoor setups can be seen below.

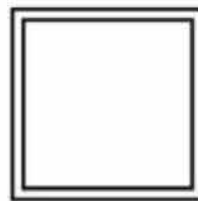
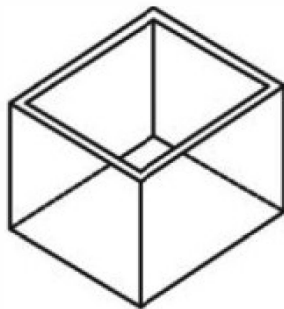

OUTDOOR AREA-EXAMPLE 1

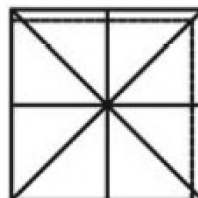
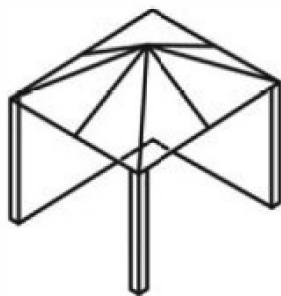

OUTDOOR AREA-EXAMPLE 2

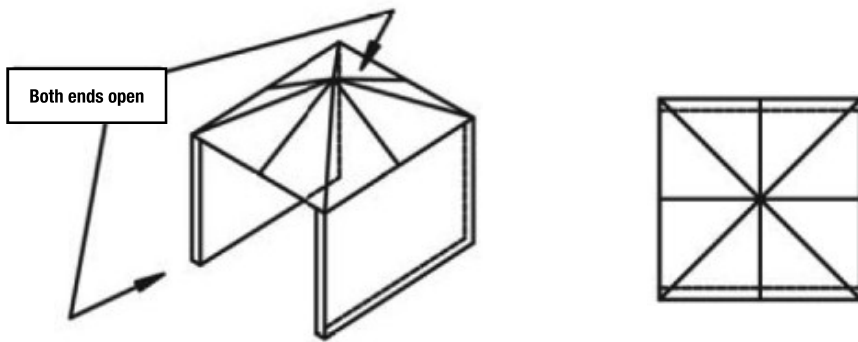

OUTDOOR AREA-EXAMPLE 3

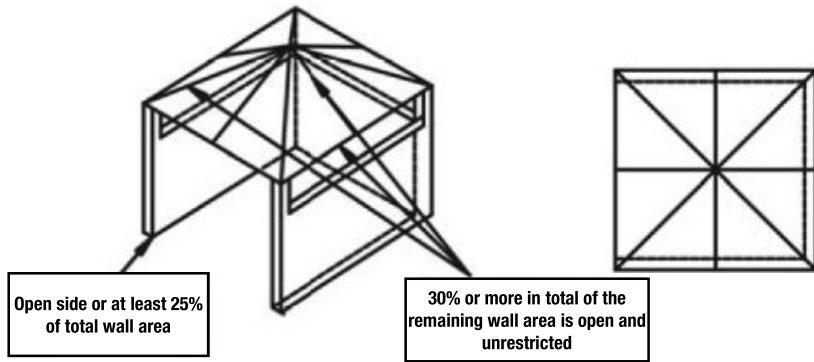

OUTDOOR AREA-EXAMPLE 4

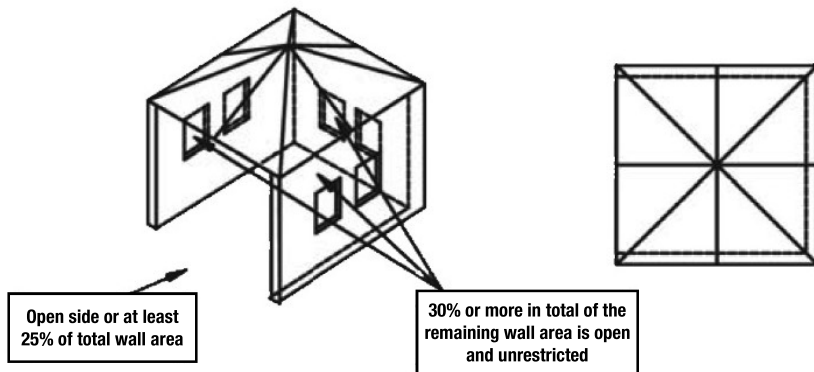

OUTDOOR AREA-EXAMPLE 5



WARNING
STORE CYLINDER IN A WELL-VENTILATED
AREA
OUT OF REACH OF CHILDREN

IMPORTANT

- This product is for outdoor use only. Do not use indoors. Do not use below ground level.
- Do not store gas cylinders below ground level. LP gas is heavier than air so if a leak occurs the gas will collect at a low level and could ignite in the presence of a flame or spark.
- Do not store or use LP gas cylinders on their side as this could allow liquid gas into the supply lines with potential serious problems.
- Leak test your BBQ before each use. Leak test the hose connections each time you reconnect the gas cylinder.
- Always turn off the gas at the cylinder when not in use.
- Inspect the hose before each use. If there is evidence of excessive abrasion or wear, or the hose is cut it must be replaced prior to the outdoor gas BBQ being put into operation. Only use hose supplied from the manufacturer.

You must have the correct gas cylinder, regulator and hose for this BBQ to operate safely and efficiently. Use of an incorrect gas cylinder, regulator or hose is dangerous and will void the warranty on this product.

CARE AND MAINTENANCE

Remember to turn off and disconnect the gas before any maintenance is carried out.

1. If your BBQ uses a flexible hose to connect to the gas cylinder, check the rubber O-ring on the regulator end of the hose assembly at least once a year. If it appears worn or cracked, have it replaced.
2. We recommend having your BBQ checked by an authorised service agent every 5 years. This is to ensure there are no leaks and that all components are still functioning correctly.
3. Keep the outdoor gas BBQ area clear and free from combustible materials, gasoline, and other flammable vapors or liquids.
4. Make sure there is no obstruction surrounding the BBQ, which may block the flow of combustion and ventilation air.
5. To maintain the surface of your hotplate and grill plate, it is recommended to periodically wash cooking surfaces with a mild soap and warm water solution. Afterwards keep the hotplate and grill plate oiled and covered with the hood when not in use. A BBQ cover (not included) is also recommended to cover your BBQ and maintain and protect from all weather conditions.



PRODUCT WARRANTY

Thank you for purchasing one of our quality MATADOR products. Your MATADOR product is covered against defects for a period of 5 years for parts and labour, repair or replacement. This warranty excludes surface rust and damage caused by abuse or neglect.

This warranty in **Australia** is given by Pacific Gas & Heating Pty Ltd,
Tel: 1300 793978
Email: service@pacifictrends.com.au

The warranty in **New Zealand** is given by Bunnings NZ Ltd, PO BOX 14436, Panmure, Auckland, 1741.
Tel: 1800 797 586 Fax: 09-9782222
Email: onlineEnquiries@bunnings.co.nz

Any claim under this warranty must be made within 5 years of the date of purchase of the product. Proof of purchase must be presented.

Goods presented for repair may be replaced by refurbished goods of the same type rather than being repaired. Refurbished parts may be used to repair the goods.

FOR AUSTRALIAN CUSTOMERS

To make a claim under the warranty please contact the store where the product was purchased or contact Pacific Gas & Heating Pty Ltd directly.

CONDITIONS OF THE WARRANTY

The warranty covers domestic use only and does not apply to commercial applications. You may submit details and proof to our store for consideration.

The warranty covers manufacture defects in materials, workmanship and finish under normal use. This warranty is provided in addition to other rights and remedies you

may have under law: our goods come with guarantees which cannot be excluded under the Australian Consumer Law. You are entitled to replacement or refund for a major failure and to compensation for other reasonably foreseeable loss or damage. You are also entitled to have the goods repaired or replaced if the goods fail to be acceptable quality and the failure does not amount to a major failure.

FOR NEW ZEALAND CUSTOMERS

To make a claim under the warranty, take the product (with proof of purchase) to any Bunnings store (See www.bunnings.co.nz for store locations). This warranty is provided in addition to other rights and remedies you may have under law: our goods come with guarantees which cannot be excluded under the Consumer Guarantees Act 1993(NZ). You are entitled to replacement or refund for a major failure and to compensation for other reasonably foreseeable loss or damage. You are also entitled to have the goods repaired or replaced if the goods fail to be of acceptable quality and the failure does not amount to a major failure.

Goods presented for repair may be replaced by refurbished goods of the same type rather than being repaired. Refurbished parts may be used to repair the goods.

The warranty excludes damage resulting from product misuse or product neglect.

The warranty covers domestic use only and does not apply to commercial applications.

PRODUCT WARRANTY

Please thoroughly read conditions of warranty

- The appliance must be operated and maintained in accordance with the instructions supplied in the operating manual.
- Any repair does not extend the warranty period.
- Any parts other than original Matador parts will void this warranty.

INSTALLATION CONDITIONS

All installations must conform to the applicable Electrical and Building standards as laid down by the local codes or state or region.

WHAT IS NOT COVERED IN THE WARRANTY

- Removal or re-installation costs. This warranty does not cover costs for transit nor in home service.
- Lack of maintenance, abuse, neglect, misuse, accidental or improper installation of this appliance.
- Scratches, dents, corrosion or discolouration caused by heat, abrasive chemical cleaners or chipping.
- Corrosion or damage caused by exposure to the elements such as insects, weather or hail.
- Cleaning and wear and tear; service calls of this nature are chargeable. Commercial use of the product.
- Unauthorised repairs or modifications during the warranty period.
- Consumable items, example – heating elements.

RECORD THE FOLLOWING INFORMATION

Attach a copy of the purchase receipt here:

Date of purchase

Purchase from

Location

Model no. & name

Date of manufacture

Receipt number

FOR TECHNICAL ASSISTANCE

FOR AUSTRALIAN CUSTOMERS

If you experience any technical issues with your MATADOR product, in the first instance review the instruction manual or call the warranty service agent below.

FOR NEW ZEALAND CUSTOMERS

If you experience any technical issues with your MATADOR product, in the first instance review the instruction manual or call your local Bunnings Warehouse.

WARRANTY CLAIMS

FOR AUSTRALIAN CUSTOMERS

Please contact Pacific Gas & Heating Pty Ltd,
Tel: 1300 793978.
Email: service@pacifictrends.com.au

FOR NEW ZEALAND CUSTOMERS

Please contact the store where the product was purchased.





Visit www.matadorbbqs.com.au

For technical and warranty support call
1300 793 978 (AUS)
1800 797 586 (NZ)

Your purchase receipt will be required for warranty claims.
For spare parts contact Pacific Gas & Heating Pty Ltd.