



# Pallet Integrity

## Pallet Integrity Standard

Only wooden pallets that comply with the following specifications can be placed directly onto the racking.

- Wooden pallets 1165mm (L) x 1165mm (W) x 150mm (H) load rated to a capacity of 2 tonnes

Leading Edge Boards

Middle Boards (Topside)

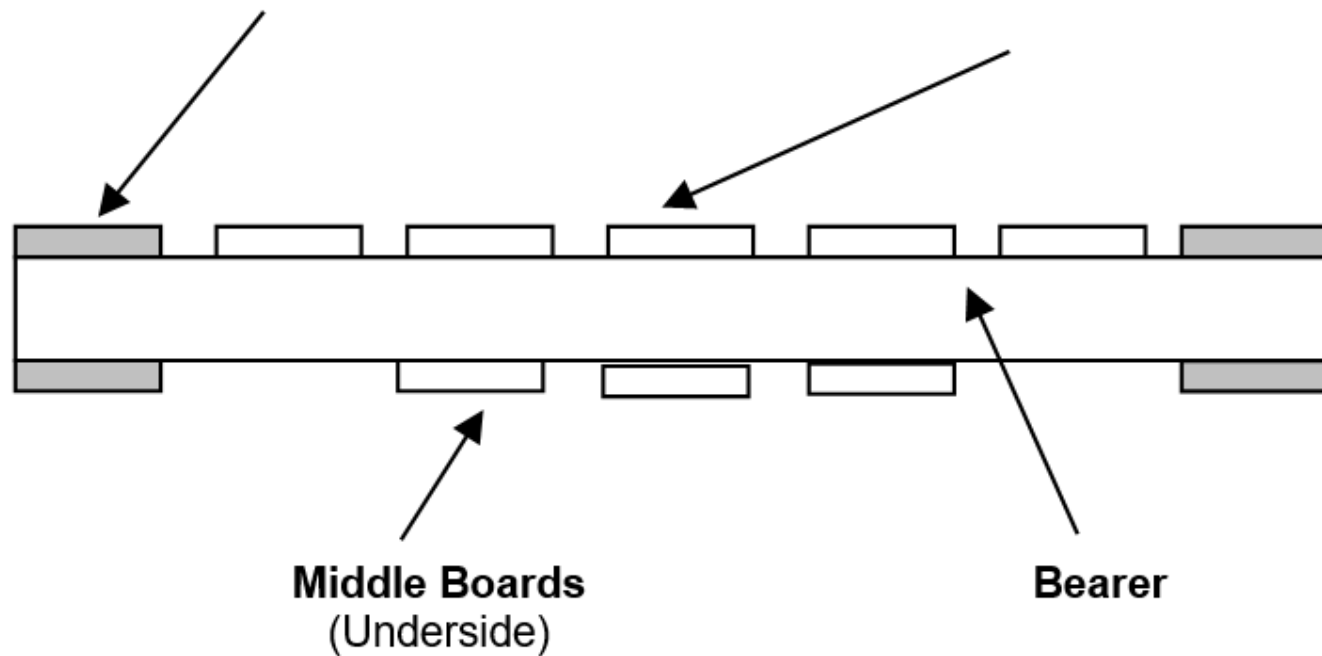

- 4 leading edge boards (top and bottom) that are intact and are at least 20mm in thickness.
- Minimum 4 top boards & 3 middle underside boards (excluding leading edge boards) that are firmly fixed to pallet with no excessive damage.
- 3 bearer supports (one on each side and one in the middle) that are structurally sound.
- Nails must not be protruding by more than 5mm.

Minor damage to the pallet is acceptable where it doesn't affect the load carrying capacity of the pallet and doesn't cause the pallet to break or fall apart during transportation or storage (see below for further details)

## Damaged Pallets

Loscam pallet guidelines can be found below to assist in the determining whether a pallet is suitable for placement into racking.

Damage to pallet boards shall not exceed the following criteria:

- A 25 mm wide chip extending through the full board depth and exceeding a length of 600mm
- Full depth splits having a length exceeding 300 mm
- Full depth cracks (broken boards)

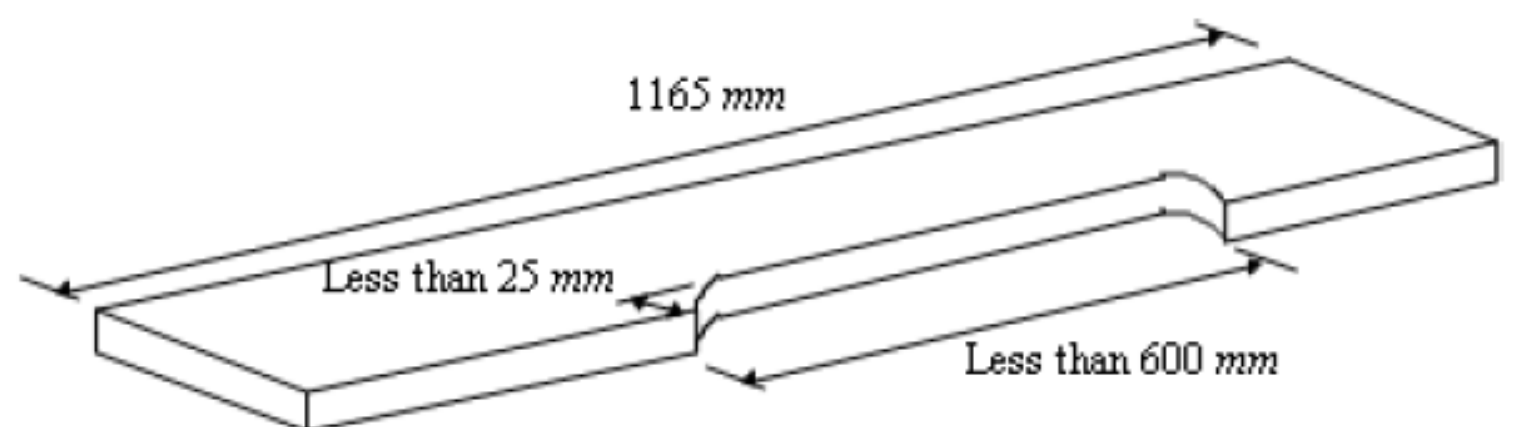
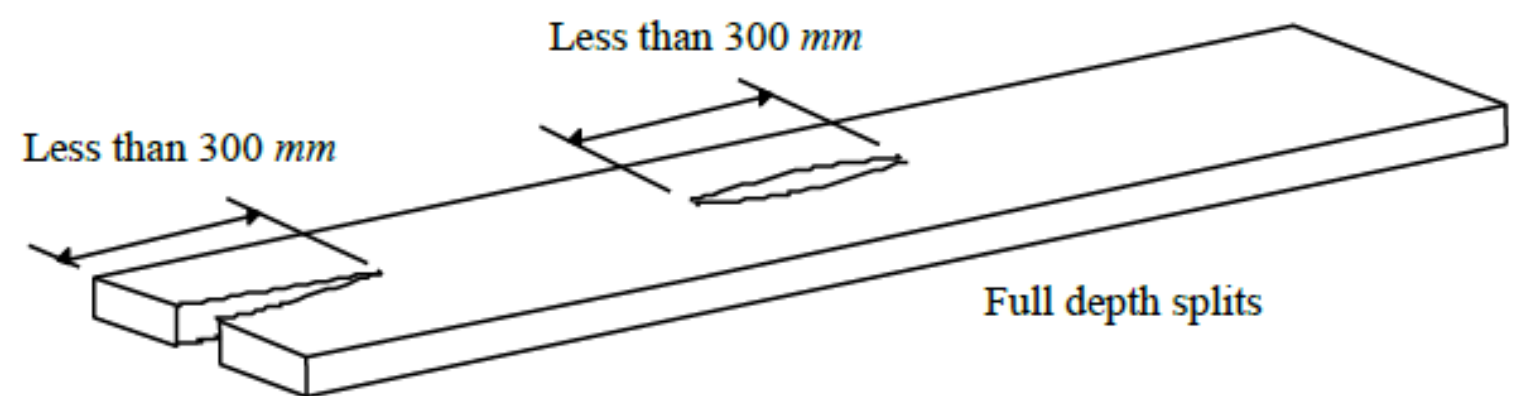
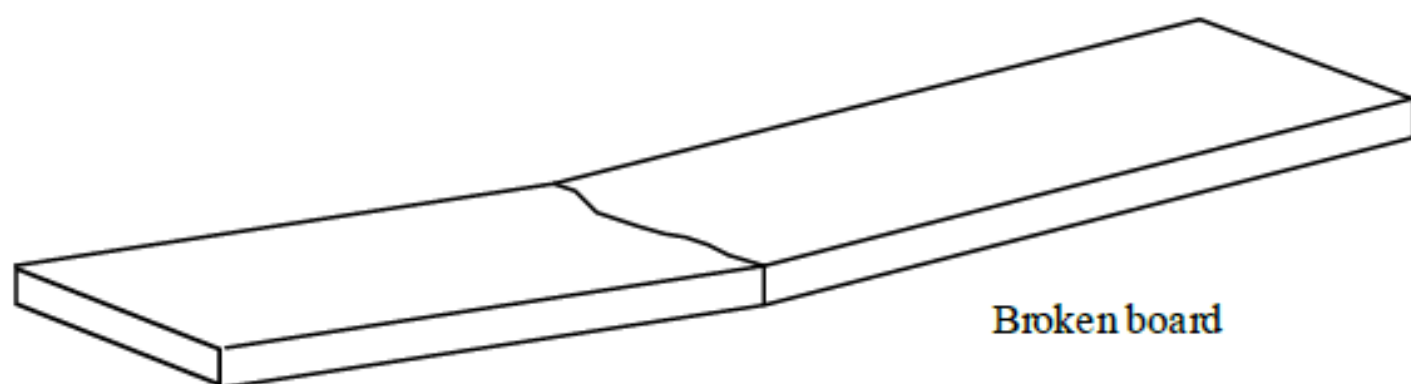

Damage to pallet bearers shall not exceed the following criteria:

- End splits shall not exceed 100 mm
- Bearers must have the capacity to securely hold the pallet boards when manipulated by hand

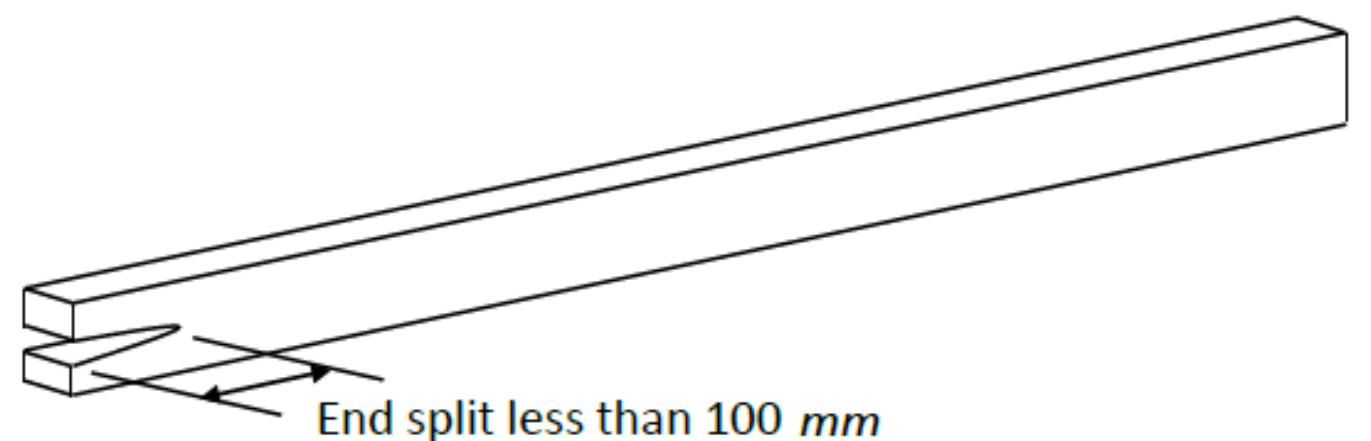

The following guidance applies when pallets are deemed to be damaged;

- Pallet repairs must only be carried out by relevant pallet supplier (e.g. Loscam repair Loscam red and Bunnings green pallets)
- Broken boards must not be removed from the pallet by our team.
- Standard pallets that are identified as damaged should be put aside and then sent via the Distribution Centre for onforwarding to the pallet manufacturer for rectification or disposal. (does not apply to skids and plain pallets)

