

Model/s
ECGG604W
ECGG905W

Version
V1.4 0922

Everything you need
for your Gas on Glass
Cooktop is in this
User Manual

esatto

Welcome

Residentia Group

—

Head Office

165 Barkly Avenue
Burnley, Victoria
Australia 3121

—

ACN

600 546 656

—

Online

residentia.group
www.esatto.house
📧 @esatto.house

—

Postage

PO Box 5177
Burnley, Victoria
Australia 3121

—

Telephone

1300 11 4357

Congratulations on purchasing your new Gas Cooktop. The Esatto brand is proudly distributed within Australia by Residentia Group Pty Ltd.

Please refer to the warranty card at the rear of this manual for information regarding your product's parts and labour warranty, or visit us online at: www.residentia.group

At Residentia Group, we are customer obsessed and our Support Team are there to ensure you get the most out of your appliance. Should you want to learn more about your new gas cooktop, it's features or importantly taking care of the appliance, our Support Team are here to help.

You can use our online Support Centre at anytime by visiting:
<http://support.residentia.group.com.au>

Or you can contact us via phone by dialing: 1300 11 HELP (4357).

It is important that you read through the following use and care manual thoroughly to familiarise yourself with the installation and operation requirements of your appliance to ensure optimum performance.

Again, thank you for choosing an Esatto appliance and we look forward to being of service to you.

Kind Regards,
The Residentia Team

Contents

Page 2
Welcome

Page 4
Safety Instructions

Page 6
Product Overview

Page 8
Before First Use

Page 9
**Using Your
Cooktop**

Page 10
Burners

Page 11
Cleaning & Care

Page 12
Troubleshooting

Page 13
Technical Data

Page 14
**Installation
Instructions**

Page 16
Gas Connection

Page 19
LPG Conversion

Page 20
**Electrical
Connection**

Page 21
**Testing Appliance
Operation**

Page 23
Purchase Details

Page 24
Warranty

Safety Instructions

IMPORTANT SAFETY INSTRUCTIONS READ CAREFULLY AND KEEP FOR FUTURE REFERENCE

Read this manual thoroughly before first use, even if you are familiar with this type of product. The safety precautions enclosed herein reduce the risk of fire, electric shock and injury when correctly adhered to. Make sure you understand all instructions and warnings.

Keep the user manual in a safe place for future reference, along with the completed warranty card and purchase receipt. If you sell or transfer ownership of this product, pass on these instructions to the new owner.

Always follow basic safety precautions and accident prevention measures when using an electrical appliance. The following statements you will see in this booklet have these meanings:

WARNING: Indicating information concerning your personal safety.

CAUTION: Indicating information on how to avoid damaging the appliance, benchtop or cabinetry.

IMPORTANT: Indicating tips and information about use of the appliance.

USAGE CONDITIONS AND RESTRICTIONS

- **Domestic use only:** This appliance is intended for indoor household use only. It is not intended for commercial, industrial or outdoor use. It is not intended for use in a recreational vehicle.
- **Purpose:** Do not use this appliance for anything other than its intended purpose. Other uses are not recommended and may cause fire, electric shock or personal injury.
- **Attachments:** The use of attachments is not recommended by the appliance manufacturer and distributor as they may be hazardous.
- **Improper use:** Damage due to improper use, or repairs made by unqualified personnel will void your warranty. We assume no liability for any eventual damages caused by misuse of the product or noncompliance with these instructions.

BEFORE USING YOUR APPLIANCE

This manual explains the proper use of your new Esatto cooktop. Please read this manual carefully before using the product. This manual should be kept in a safe place for handy reference. This rangehood is a domestic appliance which has been manufactured and tested to comply with Australian and New Zealand Standard AS/NZS 5263.

This cooktop must only be installed in accordance with the instructions provided. Incorrect installation may cause harm to persons, damage property and void the product's warranty.

Read the following carefully to avoid damage or injury.

IMPORTANT: Check for any damage or marks. If you find the appliance is damaged or marked, you must report it within 7 days if you wish to claim for damage/ marks under the manufacturer's warranty. This does not affect your statutory rights.

WARNING: Follow these instructions carefully to avoid injury or damage to your appliance.

- Do not allow pots to boil dry, as damage to both pan and cooktop may result.
- Do not operate the cooktop for an extended period without a pot or pan on the burner.
- Do not allow large cookware to overhang the cooktop onto adjacent benchtop. This will cause scorching to the benchtop surface.
- Do not allow cooking pots or pans to intrude into the area which is close to the controls.
- Ensure burner bodies and trivets are properly located on the cooktop (i.e. correctly assembled and positioned).

CAUTION: Follow these instructions carefully to avoid an electric shock or fire.

It is important to use your cooktop safely. Check these safety points before using your cooktop.

- This appliance is not intended for use by persons (including children) with reduced physical, sensory or mental capabilities, or lack of experience and knowledge, unless they have been given supervision or instruction concerning use of the appliance by a person responsible for their safety.
- Children should be supervised to ensure they do not play with this appliance.
- During use, this appliance becomes hot. Care should be taken to avoid touching hot surfaces. To avoid burns, young children should be kept away.
- This appliance must not be used as a space heater.
- Keep vents clear of obstructions.
- In order to avoid a fire, this appliance must be kept clean.
- Do not spray aerosols in the vicinity of this appliance while it is in operation.
- Do not store flammable materials on or under this appliance, e.g. aerosols.
- Do not remove the trivet and enclose the burner with a wok stand as this will concentrate and deflect heat onto the burner.
- Do not use large pots or heavy weights which can bend the trivet or deflect flame onto the burner.
- Do not place anything, e.g. asbestos mat between pan and trivet as serious damage to the

cooktop may occur.

- For maximum stability, ensure pots and pans are centrally located on the trivets.
- Handles should be turned away from the front of the bench to avoid accidents.
- Do not modify this appliance.
- Only models fitted with flame safeguard can be used in marine craft, caravans or mobile homes.

UNPACKING

During transportation, protective packaging was used to protect the appliance against any damage. After unpacking, please dispose of all elements of packaging in a way that will not cause damage to the environment.

All materials used for packaging the appliance are environmentally friendly; they are 100% recyclable and are marked with the appropriate symbol.

CAUTION: During unpacking, the packaging materials (polythene bags, polystyrene pieces, etc.) should be kept out of reach of children.

DISPOSAL OF THE APPLIANCE

Old appliances should not simply be disposed of with normal household waste and should be delivered to a collection and recycling centre for electric and electronic equipment. A symbol shown on the product, the instruction manual or the packaging shows that it is suitable for recycling.

Materials used inside the appliance are recyclable and are labelled with information concerning this. By recycling materials or other parts from used devices you are making a significant contribution to the protection of our environment.

Information on appropriate disposal centres for used devices can be provided by your local authority.



Product Overview

YOUR COOKTOP

Figure 1A — ECGG604W

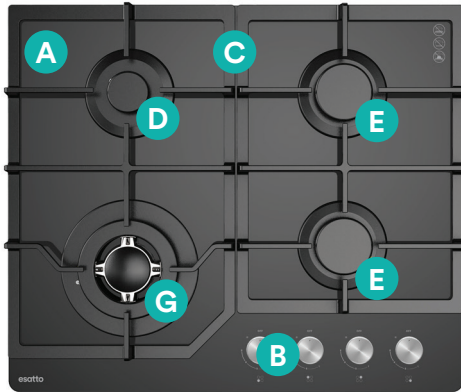
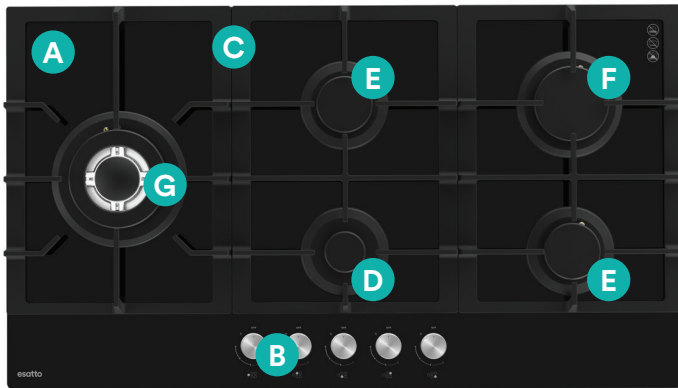

Figure 1B — ECGG905W



KEY

- A. Toughened Black Glass
- B. Burner Control Knobs
- C. Cast Iron Trivets
- D. Auxiliary Burner
- E. Semi Rapid Burner
- F. Rapid Burner
- G. Wok Burner

THE BURNER

Figure 2A

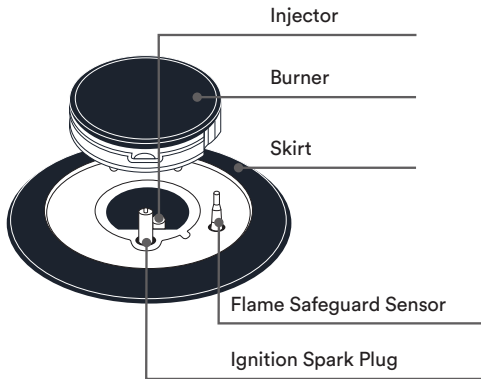
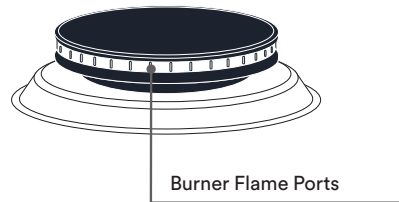

Figure 2B



COOKTOP COMPONENTS & ACCESSORIES

Your Esatto cooktop is supplied with:

- 1 × Cooktop
- 1 × Wok support trivet
- 1 × Voltage regulator valve
- 4 × Injector (ECGG604W)
- 5 × Injector (ECGG905W)
- 1 × Pressure joint
- 4 × Brackets
- 4 × Sponges
- 4 × Screws
- 1 × Elbow
- 1 × User Manual
- 1 × Quick Start Guide

Note: The images in this user manual are for reference only. Your appliance may appear differently.

Before First Use

INSTALLATION

- An authorised person must install this appliance and **MUST** provide a Certificate of Compliance. This certificate should be retained along with purchase information.
- Before using the cooktop, ensure that all packing materials are removed from the appliance.
- In order to avoid any potential hazard, the installation instructions in this booklet, and any labels on the appliance must be followed.
- Ensure that all specified vents, openings and air spaces are not blocked.
- Where the appliance is built into a benchtop, the benchtop material must be capable of withstanding 85°C.
- Ensure that the duplicate rating label (in the instruction pack) is attached to a readily accessible adjacent surface, so that the cooktop can be easily identified in the case of a service call.

SERVICING

- Servicing **MUST** only be carried out by authorised personnel.
- To maintain safe operation, it is recommended that the product be inspected every five years by an authorised service person.
- If the supply cord is damaged, it must be replaced by the manufacturer, its service agent or similarly qualified persons in order to avoid a hazard.

WARNING: Never install a cooktop that has been damaged. Please contact our Service Team for assistance.

CLEANING

- Always ensure the appliance is turned off before cleaning.
- This appliance contains aluminium fittings. Do not use caustic based cleaners.
- Do not use steam cleaners as this may cause moisture build up on electrical components.
- Always clean the appliance immediately after any food spillage.
- Do not place any components in a dishwasher.
- Refer to the Cleaning & Care section on page 11 of this user manual for instructions on cleaning and maintaining your glass hob panel.

CAUTION: Never place burners or trivets in a dishwasher.

Using Your Cooktop

STANDARD BURNER

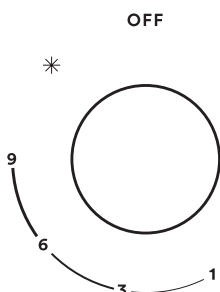

Figure 3A

TRIPLE RING WOK BURNER

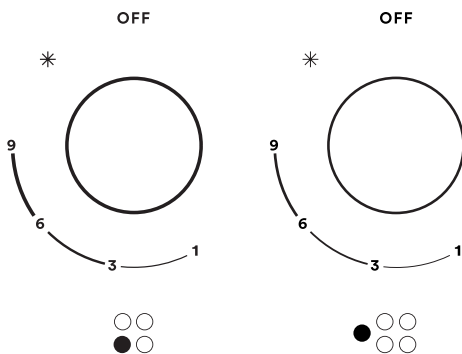

Figure 3B: ECGG604W

Figure 3C: ECGG905W

Both rings of the wok burner operate between knob rotation settings '1' and '9'.

NOTE: Gas controls turn anticlockwise from 'OFF' and have limited movement.

CONTROLS

Each burner is controlled by a control knob. The markings on the control panel indicate which burner the knob controls, and the setting for that burner (See Figure 3).

LIGHTING BURNERS

Electronic ignition: These cooktops are fitted with mains powered ignition. When the appliance has been connected and the power is on, depressing any knob will release sparks to all burners.

CAUTION:

- Keep hands clear of burners when lighting.
- If burner does not light within 5 seconds, turn knob to 'OFF' position, wait to allow gas to disperse and then try lighting again.
- Burners **MUST** be operated between '1' and '9' settings only.

To light a burner, the knob must be turned to the * position, then pushed down as far as possible for approximately 5 seconds. If the flame goes out when the knob is released simply depress the knob again, this time holding it down with slightly more force for the same length of time.

The height of the flame can be varied by turning the control knob toward the '1' position.

NOTE: When the wok burner is turned to setting 1, only the small inner ring stays lit. This is a normal function of the dual wok burner to provide a very low power flame option.

In the absence of electrical power, carry out the ignition directly to the burner with a hand held ignition source.

Note: The diagrams in this user manual are for reference only. Your appliance may appear differently.

Burners

CHOICE OF BURNER

For your convenience there is a choice of burners to choose from:

- A small Auxiliary burner for special low heat and slow cooking. Minimum pan size 120mm (Maximum 160mm).
- A medium Semi-Rapid burner for normal cooking and simmering. Minimum pan size 160mm (Maximum 180mm).
- A large Rapid burner (ECGG905W only) for fast heating and large pots and pans. Minimum pan size 200mm (Maximum 240mm).
- A Triple Ring wok burner for very fast heating using a wok or large pot or pan. Minimum pan size 200mm (Maximum 240mm).

To conserve gas place the pan centrally over the burner and adjust the flame so that it does not extend past the edge of the pan (Figure 4). Do not boil food too rapidly. A vigorous boil will not cook food any faster, and will waste energy.

POTS AND PANS

All common pots and pans; aluminium, stainless steel, cast iron, ceramic, etc., may be used on your new gas cooktop. Ensure that the pots or pans are steady and have flat bases to avoid dangerous spill-over of hot liquids and wasted energy.

CAUTION:

Never use asbestos mats, wire mats or grids, or aluminium foil as it can lead to overheating, cracked enamel or broken glass. The warranty will be void if these items are used and cause a failure. Woks should only be used on the wok burner and the wok support trivet. Refer to Figure 1A & 1B on page 6 depending on your model.

Figure 4



INCORRECT
A flame that is too high will cause gas wastage along with possibility of heating or damage to your handles.



CORRECT
A correct flame height will save gas usage.



CORRECT
For a large burner, use a large utensil.



CORRECT
For a small burner, use a small utensil.

Cleaning & Care

CAUTION:

Ensure the appliance is off and cool before cleaning.

TRIVETS

Persistent stains may require rubbing with a nylon scourer or creamed powder cleansers. Household enamel cleaners are available, follow the manufacturer's instructions in their use.

Harsh abrasive cleaners, powder cleaners, steel wool or wax polishes should not be used.

GLASS HOB

The glass used as the primary hob has been toughened and manufactured to the highest possible standards for both safety and reliability. However, it must be remembered that as it is glass, it may break. Treat it accordingly. To clean the glass hob use a soft cloth or sponge with detergent and warm water.

CAUTION: Try to clean up and remove spillages immediately, while the hob is still hot! Especially sugar and foods with a high sugar content (eg. jam), melted plastics and foil, all of which can damage the hob if left.

WARNING! If the surface is cracked, switch off the appliance immediately to avoid the possibility of electric shock.

If the hob requires extensive cleaning:

1. Remove soilage using the razor blade scraper. Angle the scraper at approx. 45° and scrape away the spillage. The razor blade can be pressed down hard onto the hob without causing any damage.
2. Use a hob cleaner product after there has been sufficient time allowed for the hob to cool. Shake the bottle and apply a small quantity of cleaner directly onto the hob. Rub clean using a damp cloth or paper towels.
3. Use a damp cloth to remove all remaining traces of the cleaner, which could otherwise burn on when the hob is next used. Wipe the hob dry.

TRIVETS AND BURNERS

These can all be lifted off and removed for separate cleaning.

CAUTION: When refitting the burners, ensure that they are correctly seated.

Ensure burners are thoroughly dried after cleaning or spillage. When cleaning the burners, ensure that all the flame ports are free of any blockage (refer to Figure 2B on page 7). If necessary, use a toothpick or brush to clear ports. The outer surface of the burner caps have a polished finish and extra care needs to be taken to avoid scratching this surface during cleaning. In instances of heavy soiling, it may be necessary to apply a non-abrasive cleaning compound and rub with a cloth until the soiling is removed and then finish with a soft, dry cloth.

WARNING:

NEVER place trivets or burners in the dishwasher.

IGNITION SPARK PLUG & FLAME SAFEGUARD SENSOR

Gently clean the ignition spark plug and flame safeguard sensor with a damp cloth to avoid lighting difficulties. Ensure that they are dry before use.

INJECTOR

Ensure the injector remains free of any foreign material. If necessary, use a thin piece of wire to clear the orifice.

Troubleshooting

If you have a problem with the cooktop, check the table below. You may be able to solve the problem and this will save you from paying for a service call. You will have to pay for a service call even in the warranty period if the problem is one listed below.

Table 1

PROBLEM	POSSIBLE CAUSE	SOLUTION
Burner will not light even though the sparker is working	Knob not held down long enough in '9' position for flame safeguard.	Repeat lighting procedure and hold knob down for 5 seconds in '9' position. (Refer page 9).
	Gas supply valve turned off.	Turn on gas supply to appliance.
	Wrong knob turned.	Ensure the knob you are turning corresponds to the burner you want to light.
	Port blockage in ignition area.	Ensure that ports in ignition area are clean and dry.
	Ignition spark plugs wet or dirty.	Dry or clean ignition spark plugs.
No spark is obtained when control knob is activated	Electricity supply is disconnected or switched off.	Switch on electricity or check fuses.
	Ignition spark plugs wet or dirty.	Dry or clean ignition spark plugs.
Flames uneven or tending to lift	Flame ports blocked or wet.	Clean or dry flame ports.
	Burner cap incorrectly fitted.	Ensure this component is fitted correctly.
Flames not staying on when knob is released	Knob not held down long enough in '9' position for flame safeguard to engage.	Repeat lighting procedure and hold knob down for 5 seconds in '9' position. (Refer page 9).
	Knob not set between '1' and '9'	Knob MUST be set between these positions.
	Dirt or spillage on flame safeguard sensor.	Clean flame safeguard sensor tip.
Low heat, slow cooking	Incorrect cooking pot or pan being used.	Refer to Figure 4 (page 10).
Benchtop or knobs overheating	Incorrect cooking pot or pan being used.	Refer to Figure 4 (page 10).
	Pot or pan not located on burner properly.	Ensure pot or pan is centrally located on burner.

Technical Data

Esatto reserves the right to alter these specifications. This appliance conforms to AS/NZS 5263.

Table 2

FEATURES	ECGG604W	ECGG905W
Burners	4	5
Wok	Yes, triple ring Wok	Yes, triple ring Wok
Ignition	220–240V~	220–240V~
Trivet	Cast Iron	Cast Iron
Hob Material	Toughened Glass	Toughened Glass
Features	Ignition under knob	Ignition under knob
Flame Failure Safety	Yes	Yes
Colours	Black Glass	Black Glass
Gas Types	NG (LP conversion kit supplied)	NG (LP conversion kit supplied)

COOKTOP PHYSICAL DIMENSIONS (mm)

Width	600	900
Depth	510	510
Height	100	100

CUT OUT DIMENSIONS (mm)

Width	560	830
Depth	490	490

ENERGY RATING (NG) – MJ/h

Auxiliary burner	4.3	4.3
Semi Rapid burner × 2	6.3	6.3
Rapid burner	N/A	10.8
Wok burner	13.5	13.5
Total MJ/h	30.4	41.2

Installation Instructions

This appliance must be installed by an authorised person and in compliance with:

- AS/NZS 5601.1 Gas Installations Part 1: General Installations, and AS/NZS 5601.2 Gas Installations Part 2: LP Gas installations in caravans and boats for non-propulsive purposes, or the relevant installation code for gas appliances in your country.
- The local gas fitting regulations, municipal building codes, electrical wiring regulations and any other relevant statutory regulations.
- The particular instructions as given below.
- A certificate of compliance MUST be given to the customer after the application is successfully installed.

CAUTION: Cooktops are supplied set up for natural gas (NG). To use on LPG, the injectors must be changed using the conversion kit supplied. Refer LPG Conversion on page 19.

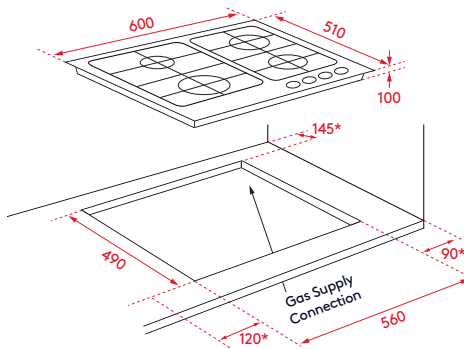

Figure 5A – ECGG604W

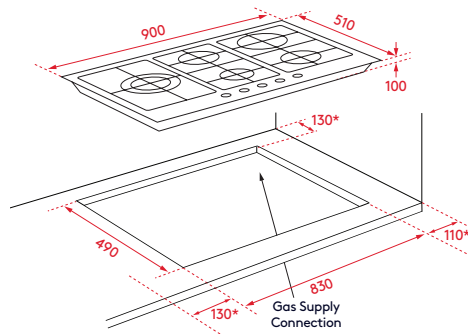

Figure 5B – ECGG905W

* Minimum clearance from cut-out to combustible surface.

NOTE: This dimension is not relevant if the adjacent surface is non-combustible.

INSTALLATION PROCEDURE

- The bench cutout should be made as per cutout dimensions in Table 2 and Figure 5A & 5B (depending on your model).
- **Adjacent walls, cupboards and protection for combustible materials:** Ensure that the appliance is installed in accordance with AS/NZS 5601.1, or AS/NZS 5601.2 with regard to clearances to combustible surfaces and materials, and clearances to rangehoods and exhaust fans.

To ensure clearances to combustible surfaces observe the minimum distance requirements shown in Figure 5A & 5B (relevant to your model).

Clearances to combustible surfaces may be reduced if combustible surfaces are protected in accordance with AS/NZS 5601.1, or AS/NZS 5601.2.

- **Barrier:** A barrier must be installed to prevent accidental contact with the cooktop base, where the base of the cooktop is accessible from below (i.e. Inside a cupboard, etc.). A minimum clearance of 25mm must be maintained between the base and the barrier. This barrier may be made of any non-combustible, rigid material.

Barrier protection is not necessary if the product is installed above an underbench oven or similar appliance and/or if the cupboard construction is such that the underside of the cooktop is not accessible.

- Ensure that there is an earthed power outlet within 900mm of the rear right hand side of the cooktop when installed. This should be accessible at all times.
- A self-adhesive Foam Tape has been provided to act as a sealing agent and is to be placed around the edge of the hob underside. Ensure that there are no gaps in the Foam Tape. Take care to ensure that the seals meet without overlapping. The thickness of this Foam Tape is 3mm and the width is 10mm.

WARNING: Do not use a silicon sealant to seal the appliance against the benchtop. This will make it difficult to remove the appliance should the cooktop need a service.

- Fit the pull down clamps supplied to ensure that the cooktop cannot move after installation. Refer to Figure 6 and the following instructions.
- Remove any excess seal visible after installation

WARNING: Failure to fix the cooktop to the bench could result in loosening of the gas connection through movement of the cooktop and a gas leak may result.

Clamps and screws are supplied with each cooktop. Fit the clamps as shown in Figure 6.

When benchtops are less than 35mm in thickness, it may be necessary to fit a spacer between the benchtop and each clamp to ensure clamps can be tightened sufficiently.

FITTING THE CLAMPS

- Ensure that the hob is free from all burner pieces and trivets. Place the hob upside down on a soft surface to protect both the hob and your worksurface from damage.
- Place the bracket (B) over the holes that match the size of the screws. There are one set of screw holes in each corner of the hob. Slightly tighten a screw (C) through the bracket (B) so that the bracket is attached to the hob whilst still allowing you to adjust it's position.
- Carefully turn the hob back over and then gently lower it into the aperture hole that you have cut-out in your benchtop.
- On the underside of the hob, adjust the brackets into a position that is suitable for your benchtop. Then fully tighten the screws (C) to secure the hob into position.

Figure 6

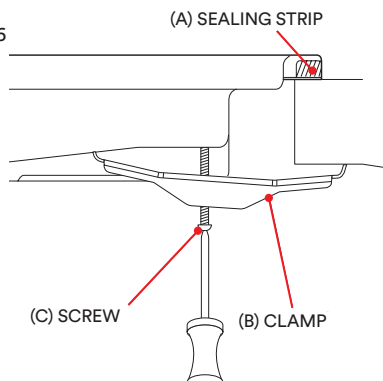

Gas Connection

OPERATION ON N.G./S.N.G

This appliance is supplied for use with Natural Gas. However, it can be converted for use with LPG. Refer to LPG Conversion on page 19.

SUPPLY PIPE SIZING

The total hourly gas consumption for the appliance is shown on the data label. The required supply pressure (i.e. at inlet to appliance regulator) for each gas type is shown on the data label, and given in Table 3 (page 18). Use this information in conjunction with the length of run, number of elbows, tees and bends, the available service pressure and the supply requirements of other installed appliances to determine a suitable pipe size.

For assistance in this matter refer to the appropriate section of AS/NZS 5601.1 or AS/NZS 5601.2.

An AGA certified class B or D flexible connection may be used to connect the cooktop in accordance with AS/NZS 5601.1, in particular section 5.9 and clause 6.10.1.8, or AS/NZS 5601.2, in particular section 2.11.

Where a hose assembly is used and the cooktop is in the installed position, the hose assembly shall be suitable for connection to a fixed consumer piping outlet located at a point 800 – 850mm above the floor and in the region outside the width of the appliance to a distance of 250mm. The point of connection to consumer piping must be accessible with appliance installed.

ELBOW POSITIONING

It is possible to reposition the elbow if required by loosening the locking nut and elbow by using two spanners. Re-tighten the entire assembly after the elbow has been repositioned. When fitting elbow to appliance, ensure that the sealing washer is fitted.

Note to Installer: Assembly of elbow to manifold at rear of unit requires two spanners to secure locking nut and ensure leak free connection. For this reason the elbow is best secured onto cooktop manifold before installing unit into benchtop.

REGULATOR

An appliance regulator is provided. The regulator must be positioned so that the pressure test nipple is accessible when the appliance is installed.

Connect the gas supply to the ½" B.S.P. internal thread inlet of the regulator. Refer to 'bench cutout' Figure 5A & 5B (relevant to your model) for connection point position. Regulators are supplied pre-adjusted and configured by the component maker for use with Natural Gas.

The appliance installer is not required to make an adjustment to obtain the correct outlet pressure setting.

An arrow on the base of the regulator indicates the direction of gas flow when the inlet and outlet of the regulator is orientated correctly. When the regulator has been fitted check for leaks from the connections with soapy water.

ASSEMBLY OF THE REGULATOR

The assembly of the regulator to the cooktop manifold is achieved via the elbow union and sealing washer supplied, refer to Figure 7.

The ½" parallel thread connects to the manifold, and the sealing washer is placed between the manifold end and the flat face on the elbow. The ½" tapered thread connects to the outlet of the regulator, and is sealed on the thread using approved thread sealing tape or approved thread sealing compound.

The inlet of the regulator is a ½" parallel thread and is connected to consumer piping or hose assembly.

Regulators are supplied pre-adjusted and configured by the component maker for use with Natural Gas.

The appliance installer is not required to make an adjustment to obtain the correct outlet pressure setting.

An arrow on the base of the regulator indicates the direction of gas flow when the inlet and outlet of the regulator is orientated correctly. When the regulator has been fitted check for leaks from the connections with soapy water.

Figure 7

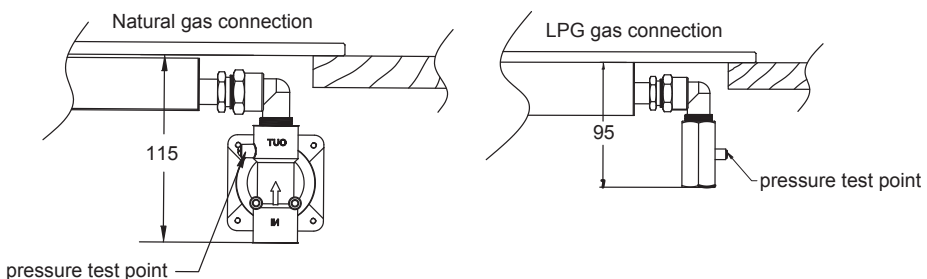

Gas Connection (Continued)

CHECKING THE GAS SUPPLY

- Check the manometer zero point is correct.
- Connect the manometer to the cooktop pressure point. This is located on the regulator.
- Turn on the gas supply and electricity and try to ignite the gas.

NOTE:

It will take additional time to light the gas for the first time as air needs to be purged from the pipes.

With the appliance operating check the outlet pressure:

- When all burners of the appliance are operating at maximum.
- When the smallest burner of the appliance is operating at minimum.

Under these conditions the outlet pressure should not vary from the nominal outlet pressure of 1.00kPa by more than $\pm 0.20\text{kPa}$.

If the regulator appears to not be performing satisfactorily, then check the following points:

- If the outlet pressure is consistently too low then the inlet pressure may be too low and adjustment of an upstream regulator may be needed, or an upstream regulator or valve with insufficient flow capacity may be present in the gas supply line. If this is suspected then it may be necessary to repeat the checks whilst measuring both the inlet and outlet pressure to determine if the inlet pressure is in the range 1.13 – 5kPa.
- Check that the regulator has been fitted to the gas supply line in the correct orientation, the arrow on the base of the body indicates the direction of gas flow.

Once these checks have been completed, if the regulator still fails to perform in a satisfactory manner it should be replaced.

Table 3A – ECGG604W

Burner Type	Natural Gas (Nominal Test point pressure: 1.00kPa)		LPG (Nominal Test point pressure: 2.75kPa)	
	Injector Size (mm)	Gas Consumption (MJ/h)	Injector Size (mm)	Gas Consumption (MJ/h)
Auxiliary burner	0.93	4.3	0.58	4.3
Semi Rapid burner	1.15	6.3	0.68	6.3
Rapid burner	—	—	—	—
Wok burner	1.72	13.5	1.0	13.5

Table 3B – ECGG905W

Burner Type	Natural Gas (Nominal Test point pressure: 1.00kPa)		LPG (Nominal Test point pressure: 2.75kPa)	
	Injector Size (mm)	Gas Consumption (MJ/h)	Injector Size (mm)	Gas Consumption (MJ/h)
Auxiliary burner	0.93	4.3	0.58	4.3
Semi Rapid burner	1.15	6.3	0.68	6.3
Rapid burner	1.5	10.8	0.9	10.8
Wok burner	1.72	13.5	1.0	13.5

LPG Conversion

This appliance is supplied set up for Natural Gas usage. A conversion kit is included with the product for Universal LPG usage. The conversion kit contains the appropriate injectors, 1 Brass Test Point and 1 LPG sticker.

Please follow the procedure below if a conversion to suit UNIVERSAL LPG is required:

- Remove the hotplate trivets, burner caps and burner crowns to access the hotplate injectors. Replace the factory fitted injectors with the appropriate injectors, as supplied. Refer to injector orifice table for injector sizes. The injector size is stamped on the side of the injector.
 - Connect the brass test point adapter (pictured opposite) using approved gas thread tape or compound to the elbow fitting.
 - Turn on the gas supply and at each new connection check for leaks using soapy water. Each hotplate valve should be turned on, one at a time, and the injector hole blanked off for several seconds.
 - With the appliance operating check the outlet pressure when all burners of the appliance are operating at maximum, when the smallest burner of the appliance is operating at minimum.
Under these conditions the outlet pressure should not vary from the nominal outlet pressure of 2.60kPa by more than $\pm 0.52\text{kPa}$.
- If the regulator appears to not be performing satisfactorily then check the following points:
 - If the outlet pressure is consistently too low then the inlet pressure may be too low and adjustment of an upstream regulator may be needed, or an upstream regulator or valve with insufficient flow capacity may be present in the gas supply line.
 - If this is suspected then it may be necessary to repeat the checks whilst measuring both the inlet and outlet pressure to determine if the inlet pressure is in the range 2.75 – 7.00kPa.
 - One by one, turn the knobs to minimum and screw in the bypass screw (accessible when the knob is removed) until a small stable flame results; a length of 3-4mm. Turn the knob to maximum and then back to minimum to ensure that the correct minimum flame is maintained.
 - Attach the LPG sticker to the cooker, near the gas supply inlet. Cover the Natural Gas label that is factory fitted.

Electrical Connection

ELECTRICAL CONNECTION (220-240 VOLTS)

The appliance is supplied with a standard 7.5 Amp service cord terminated by a 3-pin plug for connection to a standard 10 Amp household socket. The electrical supply is required to power the electronic ignition system.

Note: It will be necessary for servicing purposes to disconnect the electrical power supply. The power point should therefore be accessible after the appliance is installed, as specified in the local wiring regulations.

Diagram 1A & 1B (depending on your model) are schematics of the wiring in the appliance.

IMPORTANT:

This appliance must be earthed. This appliance is designed to be connected to a 220-240V, 50Hz-60Hz AC electricity supply. The wires in the mains lead are coloured in accordance with the following code:

1. Green/Yellow = Earth
2. Blue = Neutral
3. Brown = Live

IMPORTANT: The wire which is coloured Green/Yellow must be connected to the terminal which is marked with the letter E or by the Earth symbol.

WARNING: When the power cord is damaged it must be replaced by the manufacturer, its service agent or similarly qualified persons in order to avoid a hazard.

Diagram 1A – ECGG604W

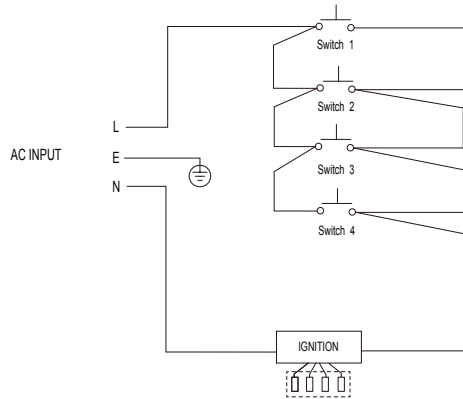
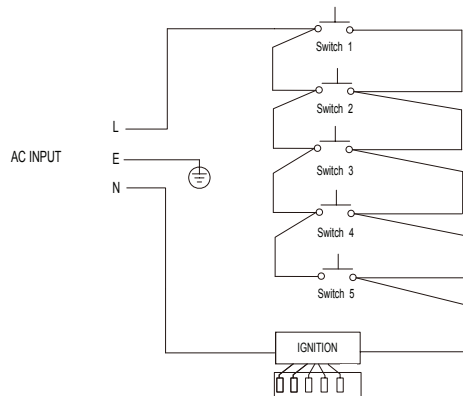

Diagram 1B – ECGG905W



Testing Appliance Operation

After installation, test the appliance and ensure that it operates correctly before handing it over to the customer. The following procedure is recommended:

- Turn on the gas and electricity supply and attempt ignition on all burners, both separately and in combination. (For correct procedure refer to page 9 Lighting Burners). Note that additional time needs to be allowed for the initial lighting as air has to be purged from the pipes.
- Observe the flame appearance on each burner (Figure 9). If it is much larger or much smaller than expected, the injector size and supply pressure require checking. Where a flame is unsatisfactory, refer to the Troubleshooting Guide (page 12) to correct the fault. If the Troubleshooting Guide does not solve the problem, please call the Service Centre.
- When all the foregoing is satisfactory, check the turndown (minimum or low) setting on each burner, as this may need adjustment. Valves have a bypass controlling screw, which may be accessed by removing the knob. This screw will be located on a particular area of the valve (refer Figure 10). Normally, this will have been correctly set at the factory for use on Natural Gas (NG) and should not require adjustment.

IMPORTANT: If the appliance has been converted to LPG, then the bypass screw will **HAVE** to be screwed in until a small, stable flame results.

Please ensure the supply pressure has been checked PRIOR to any adjustment.

Figure 9

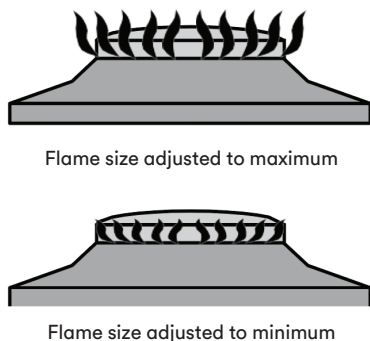

If the appliance cannot be adjusted to perform safely inform the customer of the problem and affix an appropriate warning notice to the appliance. If the fault appears to be dangerous the appliance should be disconnected. If a minor fault exists, the customer may wish to use the appliance while awaiting service.

If a fault cannot be fixed, please call the Service Centre for assistance.

The customer should be advised that, in the event of a fault, the local service organisation or the retailer from whom the appliance was purchased should be contacted.

When satisfied that the unit is operating correctly, turn off and instruct the customer on correct operation as outlined in this booklet. Ask the customer to operate the controls to ensure that the correct procedure is understood.

CAUTION: Servicing must only be carried out by an authorised service person.

Injector sizes required for various gas types are shown in Table 3A & 3B on page 18 (depending on your model). The appliance test point pressure for each gas type is also shown.

For model identification after installation, an additional data plate sticker has been provided. This sticker is to be stuck onto adjacent cabinetry.

Figure 10

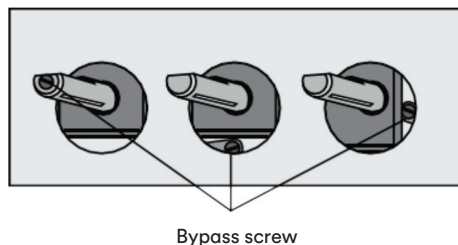

**Attach your receipt
to this page**



Purchase Details

For your records, please record details of your purchase below and staple your receipt on the opposite page. Your serial number can be found on the rating plate of your Cooktop.

STORE DETAILS

STORE NAME |

ADDRESS |

TELEPHONE |

PURCHASE DATE |

PRODUCT DETAILS

MODEL NO. |

SERIAL NO.* |

Warranty

WARRANTY TERMS AND CONDITIONS COOKTOPS

This document sets out the terms and conditions of the product warranties for Residentia Group Appliances. It is an important document. Please keep it with your proof of purchase documents in a safe place for future reference should you require service for your Appliance.

1. **IN THIS WARRANTY**
 - (a) 'acceptable quality' as referred to in clause 10 of this warranty has the same meaning referred to in the ACL;
 - (b) 'ACL' means Trade Practices Amendment (Australian Consumer Law) Act (No.2) 2010;
 - (c) 'Appliance' means any Residentia Group product purchased by you accompanied by this document;
 - (d) 'ASR' means Residentia Group authorised service representative;
 - (e) 'Residentia Group' means Residentia Group Pty Ltd of 165 Barkly Ave, Burnley VIC 3121, ACN 600 546 656 in respect of Appliances purchased in Australia;
 - (f) 'major failure' as referred to in clause 10 of this warranty has the same meaning referred to in the ACL and includes a situation when an Appliance cannot be repaired or it is uneconomic for Residentia Group, at its discretion, to repair an Appliance during the Warranty Period;
 - (g) 'Warranty Period' means:
 - (i) where the Appliance is used for personal, domestic or household use (i.e. normal single family use) as set out in the instruction manual, the Appliance is warranted against manufacturing defects for 24 months, following the date of original purchase of the Appliance;
 - (h) 'you' means the purchaser of the Appliance not having purchased the Appliance for re-sale, and 'your' has a corresponding meaning.
2. This warranty only applies to Appliances purchased and used in Australia and is in addition to (and does not exclude, restrict, or modify in any way) any non-excludable statutory warranties in Australia.
3. During the Warranty Period Residentia Group or its ASR will, at no extra charge if your Appliance is readily accessible for service, without special equipment and subject to these terms and conditions, repair or replace any parts which it considers to be defective. Residentia Group or its ASR may use remanufactured parts to repair your Appliance. You agree that any replaced Appliances or parts become the property of Residentia Group. This warranty does not apply to light globes, batteries, filters, seals or similar perishable parts.
4. Parts and Appliances not supplied by Residentia Group are not covered by this warranty.

5. You will bear the cost of transportation, travel and delivery of the Appliance to and from Residentia Group or its ASR. If you reside outside of the service area, you will bear the cost of:
 - (a) travel of an authorised representative;
 - (b) transportation and delivery of the Appliance to and from Residentia Group or its ASR, in all instances, unless the Appliance is transported by Residentia Group or its ASR, the Appliance is transported at the owner's cost and risk while in transit to and from Residentia Group or its ASR.
6. Proof of purchase is required before you can make a claim under this warranty.
7. You may not make a claim under this warranty unless the defect claimed is due to faulty or defective parts or workmanship. Residentia Group is not liable in the following situations (which are not exhaustive):
 - (a) the Appliance is damaged by:
 - (i) accident
 - (ii) misuse or abuse, including failure to properly maintain or service
 - (iii) normal wear and tear
 - (iv) power surges, electrical storm damage or incorrect power supply
 - (v) incomplete or improper installation
 - (vi) incorrect, improper or inappropriate operation
 - (vii) insect or vermin infestation
 - (viii) failure to comply with any additional instructions supplied with the Appliance;
 - (b) the Appliance is modified without authority from Residentia Group in writing;
 - (c) the Appliance's serial number or warranty seal has been removed or defaced;
 - (d) the Appliance was serviced or repaired by anyone other than Residentia Group, an authorised repairer or ASR.
8. This warranty, the contract to which it relates and the relationship between you and Residentia Group are governed by the law applicable where the Appliance was purchased.
9. To the extent permitted by law, Residentia Group excludes all warranties and liabilities (other than as contained in this document) including liability for any loss or damage whether direct or indirect arising from your purchase, use or non use of the Appliance.
10. For Appliances and services provided by Residentia Group in Australia, the Appliances come with a guarantee by Residentia Group that cannot be excluded under the Australian Consumer Law. You are entitled to a replacement or refund for a major failure and for compensation for any other reasonably foreseeable loss or damage. You are also entitled to have the Appliance repaired or replaced if the Appliance fails to be of acceptable quality and the failure does not amount to a major failure. The benefits to you given by this warranty are in addition to your other rights and remedies under a law in relation to the Appliances or services to which the warranty relates.
11. At all times during the Warranty Period, Residentia Group shall, at its discretion, determine whether repair, replacement or refund will apply if an Appliance has a valid warranty claim applicable to it.
12. Missing parts are not covered by warranty. Residentia Group reserves the right to assess each request for missing parts in a case by case basis. Any parts that are not reported missing in the first week after purchase will not provide free of charge.
13. To enquire about claiming under this warranty, please follow these steps:
 - (a) carefully check the operating instructions, user manual and the terms of this warranty;
 - (b) have the model and serial number of the Appliance available;
 - (c) have the proof of purchase (e.g. an invoice) available;
 - (d) telephone the numbers shown below.
14. You accept that if you make a warranty claim, Residentia Group and its ASR may exchange information in relation to you to enable Residentia Group to meet its obligations under this warranty.

IMPORTANT

Before calling for service, please ensure that the steps in point 13 have been followed.

CONTACT SERVICE

→ Service: 1300 11 HELP (4357)

The Australian Consumer Law requires the inclusion of the following statement with this warranty:

Our goods come with guarantees that cannot be excluded under the Australian Consumer Law. You are entitled to a replacement or refund for a major failure and for compensation for any other reasonably foreseeable loss or damage. You are also entitled to have the goods repaired or replaced if the goods fail to be of acceptable quality and the failure does not amount to a major failure.

Warranty (NZ)

NEW ZEALAND WARRANTY TERMS & CONDITIONS COOKING APPLIANCES

To help care for your investment, be sure to register your appliance online. Registration will help you if you need to arrange service in the future, and serves as a record of your purchase—including critical information like model number and serial number – that you can refer to at any time. Simply visit the below website, or ask your retailer for help: www.esatto.house/nz/registration

WARRANTY

These products are covered by a warranty for a period of 24 months from the date of purchase, subject to the following conditions*. The warranty covers rectification free of charge of any fault arising from defective materials or components, or faulty workmanship or assembly.

* The conditions above mentioned are:

1. That the purchaser carefully follows all instructions packed with the product;
 2. That the purchaser and/or installer carefully follows the installation instructions provided and complies with electrical wiring regulations, gas and/or plumbing codes;
 3. That the purchaser carefully follows instructions provided in the owner's handbook relating to the proper use and care of the product and does not use the product for any purpose other than the domestic use for which it has been designed;
 4. Commercial use of the product for professional or industrial purposes will void this warranty;
 5. That the product was purchased and installed in New Zealand;
 6. That this warranty does not extend to:
 - a) optional glass lids for hobs apart from claims which relate to mechanical or physical damage thereof at the date of purchase;
 - b) 'consumable' parts such as light bulbs or filters;
 - c) damage to ceramic glass caused by liquid or solid spill-overs, lack of maintenance, or impact;
 - d) damage to surface coatings caused by cleaning or maintenance using products not recommended by the owner's handbook;
 - e) defects caused by normal wear and tear, accident, negligence, alteration, misuse or incorrect installations;
 - f) a product dismantled, repaired or serviced by any serviceman other than an authorised service agent;
 - g) a product not in possession of the original purchaser;
 - h) damage caused by power outages or surges
 - i) damage caused by pests (eg. rats, cockroaches etc.)
7. That if the product is a freestanding microwave oven or small appliance it must be returned to the dealer/retailer for servicing. These products, unless stated otherwise, have a 12 month warranty from original date of purchase with 24 months on the microwave magnetron; Waste disposers have a 12 month warranty.
 8. The provision of service under this warranty is limited by a 25km boundary from the retailer where the product was purchased except for microwaves. Such travelling outside of these limits will incur commercial cost to be paid by you, regulated by the number of kilometres travelled beyond the 25km limit (50km return trip). Microwaves are to be delivered to the nearest authorised service agent by the customer.

Please refer to your user manual for any further conditions that may apply to your specific model.

Nothing herein contained shall be construed in any way as excluding or limiting your rights under the Consumer Guarantees Acts 1993.

For Service please visit www.applico.co.nz/service or contact the dealer/retailer from whom you purchased the product from or call the 0800 number listed below. If you are unable to establish the date of purchase, or the fault is not covered by this warranty, or if the product is found to be in working order, you will be required to bear all service call charges.

Registration of this warranty constitutes acceptance of the terms and conditions of this warranty.

Should you require any assistance, please call Customer Services on 0800 763 448.

Distributed by Applico Ltd. www.applico.co.nz July 2019

After registering your appliance online, we recommend you fill out the below information for your reference and keep this warranty card in a safe place.



E2447

esatto
everything
you need



A RESIDENTIA
GROUP INITIATIVE