

Installation Instructions and User Guide

tastic

HEAT VENT LIGHT

Model: 11303 Original

Model: 11311 Triumph 3 in 1 (275 W)

Model: 11312 Triumph 3 in 1 (375 W)

Model: 11317 Triumph 2 in 1

Model: 11335 Mirage with LED Motion Sensor

Model: 12303 Sensation

Model: 12301 Silhouette

Electrical Rating: 230~240 V. 50 Hz.

www.ixlappliances.com.au
www.ixlappliances.co.nz

Welcome

Thank you for buying this IXL Tastic. Even if you have used a Tastic before, there are very good reasons to read this user guide before using this one:

- You and your family, property and home will be safe from harm.
- You will learn how this appliance may differ from others.
- By using the Tastic fully and properly, you will get maximum life and value from it.
- Our warranty depends on you using the Tastic according to this user guide.

It will only take you a few minutes, so please read on!

Contents

Classic Tastic Range.....	Pg 3
Safety	Pg 4
How it Works.....	Pg 5
Ventilation Requirements.....	Pg 6
Clearances	Pg 7
Flat Roof Installations (with insufficient clearances)	Pg 8
Electrical Requirements	Pg 8
Wiring Diagrams	Pg 9-10
Installation	Pg 10-11
Replacement Lamps	Pg 12
Cleaning and Maintenance.....	Pg 12
FAQ's	Pg 13-15
Warranty	Pg 16-17
Notes	Pg 18
Warranty Registration	Pg 19



Model: 11303 Original



Models: 11311/11312/
11317 Triumph



Model: 11335 Mirage



Model: 12303 Sensation



Model: 12301 Silhouette

11303 Original

4 x 275 W Heat, Vent & Light
8 W LED Centre Globe
Half Heat Function
Cutout 262 mm x 262 mm
200 mm Fan, 283m³/hr or 79l/s

11311 Triumph 3 in 1

2 x 275 W Heat, Vent & Light
10 W LED Centre Globe
Cutout Template Supplied
200 mm Fan, 279m³/hr or 78l/s

11312 Triumph 3 in 1

2 x 375 W Heat, Vent & Light
10 W LED Centre Globe
Cutout Template Supplied
200 mm Fan, 279m³/hr or 78l/s

11317 Triumph 2 in 1

2 x 275 W Heat & Light
10 W LED Centre Globe
Cutout Template Supplied

11335 Mirage with LED Motion Sensor

2 x 275 W Heat, Vent & Light
10 W Motion Sensor LED Globe
Cutout Template Supplied
200 mm Fan, 279m³/hr or 78l/s

12303 Sensation

4 x 275 W Heat, Vent & Light
10 W LED Centre Globe
Half Heat Function
Cutout 330 mm x 330 mm
200 mm Fan, 392m³/hr or 109l/s

12301 Silhouette

4 x 375 W Heat, Vent & Light
10 W LED Centre Globe
Half Heat Function
Cutout 330 mm x 330 mm
200 mm Fan, 407m³/hr or 113l/s

Read through these instructions completely before commencing installation.



Do not allow insulation material to rest against the sides or top of the Tastic unit when installed. This Tastic must not be installed where there is a possibility of water splashing on to the lamps. There is no IP rating on any IXL Tastic.

NOTE: This product must be installed by a qualified installer.

The infra-red lamps heat by direct radiation rather than by heating the air in the room, so the Tastic should be located directly over where drying off occurs.

Locate the Tastic in accordance with the requirements of the current Australian/New Zealand Wiring Rules AS/NZS 3000 relating to damp situations.

In some installations this may mean that no part of the Tastic may be located directly above any part of a bath or shower recess or enclosure.

For unenclosed showers refer to Wiring Rules conditions.

Switches and other controls must not be located where they can be touched by a person in the bath or shower.

NOTE: Tastic products must only be installed horizontally in ceiling.

- Do not look directly into heat lamps when in use.
- Tastic products are not tanning lamps.
- Make sure the lamps have cooled and power is off to the Tastic before removing lamps for replacement.
- Do not operate this appliance without the fascia in position.
- This appliance is not intended for use by persons (including children) with reduced physical, sensory or mental capabilities, or lack of experience and knowledge, unless they have been given supervision or instruction concerning use of the appliance by a person responsible for their safety.
- Young children should be supervised to ensure they do not play with the appliance.
- This appliance must be mounted with the lowest point at least 2.1 metres from the floor.
- This appliance must not be mounted immediately below a socket outlet.”
- Regulations concerning the discharge of air have to be fulfilled.

WARNING: Curtains or combustible material may ignite if in contact with the heater.

The IXL Tastic range has been designed to exacting standards to give you many years of trouble-free operation. To ensure you get the most from your Tastic there are a few simple points to keep in mind.

HEAT LAMPS

The IXL Tastic Heat Lamps have no warm up period because the infra red lamps provide instantaneous heat, and are designed to heat you and not your bathroom - that's the efficient way infra red heat works. You'll save money and energy, with an average cost of around one cent a shower if used correctly, (based on average 5 minute drying time). Also, to get the full benefit of Tastic's infra red warmth, stand directly under the heat lamps. IXL's exclusive clear heat lamps have been designed specifically for this application, and concentrate their heat for maximum effectiveness.

Make sure you have the Tastic model that suits your bathroom ceiling height. This Tastic is manufactured to offer peak performance with bathroom ceiling heights up to 2.4 m for the Triumph 11311 & 11317 and Mirage 11335, 2.7 m for Sensation 12303, Original 11303, Triumph 11312 & 3.3 m for Silhouette 12301.

The Tastic half heat function is available on the 4 lamp models, and is another energy saver, allowing you to adjust the heat level to suit prevailing conditions or personal preference.

VENTILATION

To ensure optimum performance of the exhaust fan, it is essential that there is adequate air flow into your bathroom to help the Tastic's powerful and efficient exhaust fan to quickly remove steam while you shower. Your Tastic works by drawing steam-laden air from the room, and as with all exhaust fans it is essential that sufficient air inlet is provided. Ensure adequate inlets exist through windows, vents or under the door. Air flow path from inlet to fan should ideally pass over the steam source.

CENTRE LIGHT (EXCEPT MODEL 11335 MIRAGE)

The centre light in all Tastic models is designed to provide general illumination in your bathroom.

Note: For efficiency purposes, the centre light will not operate simultaneously with the heat lamps.

MOTION SENSOR LED GLOBE CENTRE LIGHT

The LED motion sensor LED globe has been specifically developed to fit the IXL Tastic Mirage (Model 11335). It is also compatible to other Tastic 3 in 1 products (except Tastic Original and Tastic Prime). It is designed to provide general illumination in your bathroom with automatic switching on and off when light switch is on. It aims to save energy and increase your level of comfort.

When the motion sensor globe is switched to the ON position at the light globe, the light globe will initially illuminate for approximately 2-3 seconds when turned on at the switch plate, at which time it will then switch off. On detection of movement the motion sensor will activate globe to full brightness.

Without any movement, the motion sensor LED globe will gradually dim to off within a period of 2 minutes. The motion sensor LED globe will dim 10 seconds before switching off, and will resume at full brightness once reactivated by movement. Detection range is between 3-5 meters from the globe. It functions through screens and shower doors. This motion sensor is applicable to the centre LED light globe only, not including the heat lamp or exhaust fan.

Note: For efficiency purposes, the motion sensor LED globe will not operate simultaneously with the heat lamps

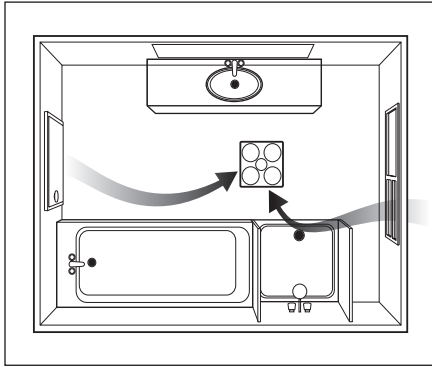

Fig. 1: Ideal placement of Tastic.
Sufficient air inlets into room are required

For maximum efficiency and fan performance there are a few key points to keep in mind when installing your Tastic.

Sufficient air inlet into room

Steam will only be removed if there is sufficient flow of air through the room. Ensure generous inlets exist through windows, vents or under the door. Air flow path from inlet to fan should ideally pass over the steam sources (see Fig. 1).

Draftstoppa type products should never be used with Tastics as it will lead to dangerous heat build up inside the unit and void the warranty.

If backdraft flaps are required then customers should buy an Eco Tastic or Easy Duct Tastic.

Adequate ventilation in roof cavity

It is essential that there is adequate space within the roof cavity so that exhaust air from the Tastic can dissipate. Where space is restricted, use Fig. 3 as a guide to minimum requirements for adequate ventilation.

The roof cavity itself should be well ventilated to outside so that moist air can be removed. Local building codes may require flueing to outside through roof or as per Fig.5 (page 8) for flat roof installation.

Where ventilation space is restricted

This product is not recommended for installation between floors of multi-storey dwellings, or where space within the roof cavity is severely restricted and a flue as per Fig.5 cannot be fitted. IXL has other Tastic products available that are particularly suited to installations between floors or where space is restricted. Contact your nearest IXL Service Centre on the number located on the back of this booklet.

For more information and advice about IXL ventilation products visit ixlappliances.com.au (Australia) / ixlappliances.co.nz (New Zealand)

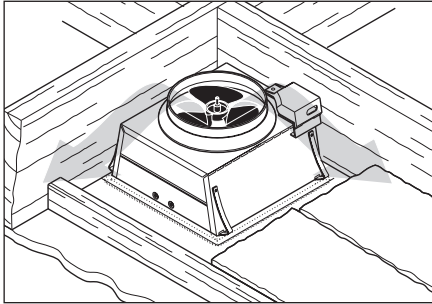

Fig. 2: Adequate open space in the roof cavity is required

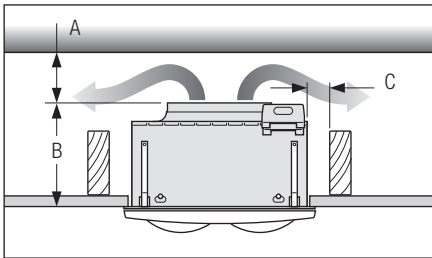

Fig. 3: Minimum clearances for installation

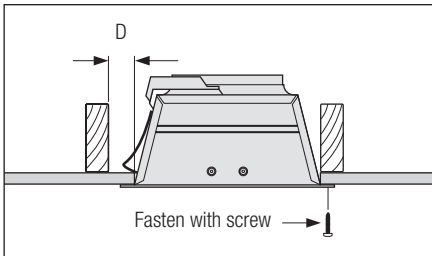

Fig. 4: Joist clearances

All appliances must be mounted so that the lowest point is at least 2.1 m above the floor. A minimum clearance of 75 mm is required above the top of the Tastic when installed in a well ventilated roof cavity. Where ventilation is restricted, this clearance should be increased by a minimum of 25 mm.

Additionally, a minimum of 15 mm clearance is required between the two vertical sides of the Tastic and any adjoining parts of the roof structure, such as walls, joists or insulation batts.

Figure 3 measurement A :

75 mm min. where there is good ventilation to the sides of the unit.

100 mm min. where ventilation to the sides of the unit is restricted

Figure 3 measurement B:

Model No's 11311, 11312, 11317 and Mirage 11335
230 mm.

Model No 11303
210 mm

Model No's 12301 & 12303
220 mm.

Figure 3 measurement C:

15 mm min. clearance on the two vertical sides.

Figure 4 measurement D:

35 mm min. clearance required when using the inbuilt clip fasteners.

Flat Roof Installations

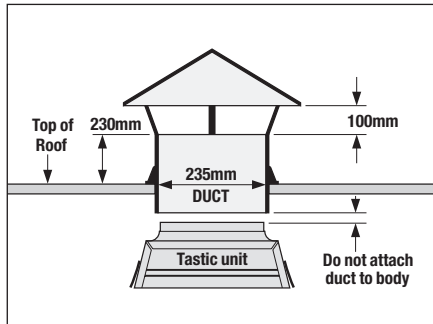

Fig. 5: Minimum external outlet requirements

When installing into a flat roof with insufficient clearance, or where ceiling cavity ventilation is restricted, an external venting duct must be installed. Use Fig. 5 as a guide to minimum external outlet requirements.

IMPORTANT: Do not attach the duct to the body of the Tastic. Allow for 10-20 mm minimum gap between the Tastic and the end of the duct.

Electrical Requirements



Tastic units are fitted with a LED centre lamp. To ensure correct operation and to prolong the life of the LED please wire as per the following wiring diagrams for the appropriate model. This will help to prolong the life of the LED.

See the wiring diagrams on the following pages for supply requirements and maximum loadings for each model. Tastics may be connected to a lighting or power circuit if loading permits. These models are for wired-in installation and wiring must be carried out by a registered electrician. *Switches and a wall plate are provided with the Tastic, attached to the unit. Remove the fascia for access. Do not use this product with any solid state speed control or commercial dimming device.

* Number of switches depends on your Tastic model.

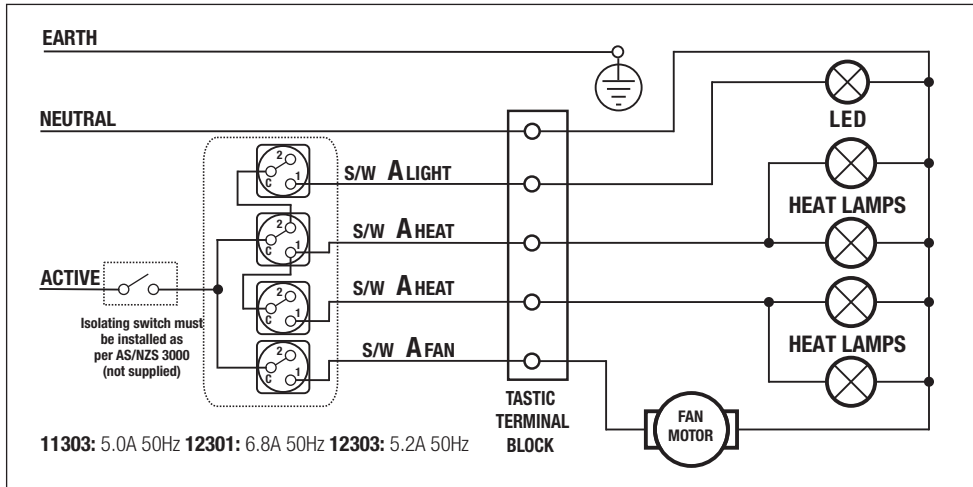

Fig. 6: Wiring diagram for model 11303, 12301 and 12303.

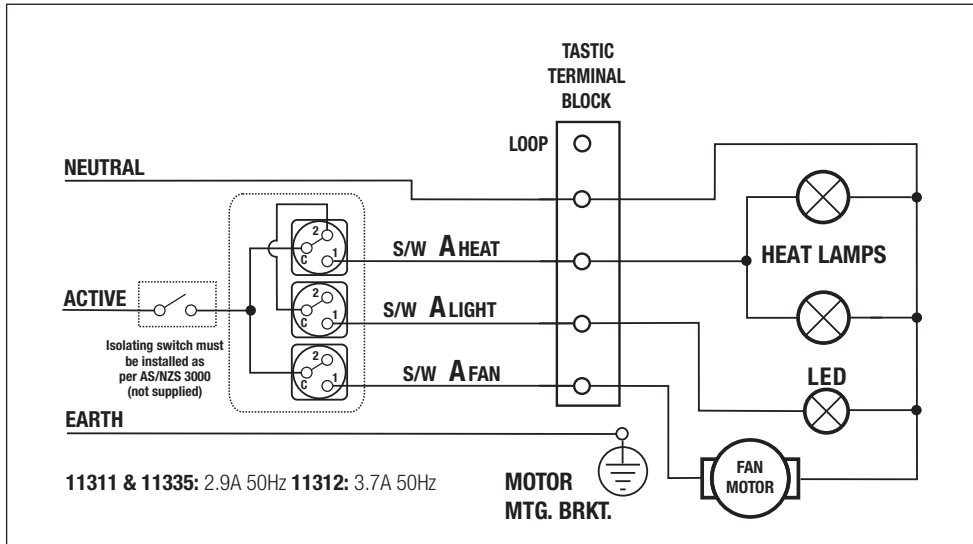

Fig. 7: Wiring diagram for model 11311, 11312 and 11335.

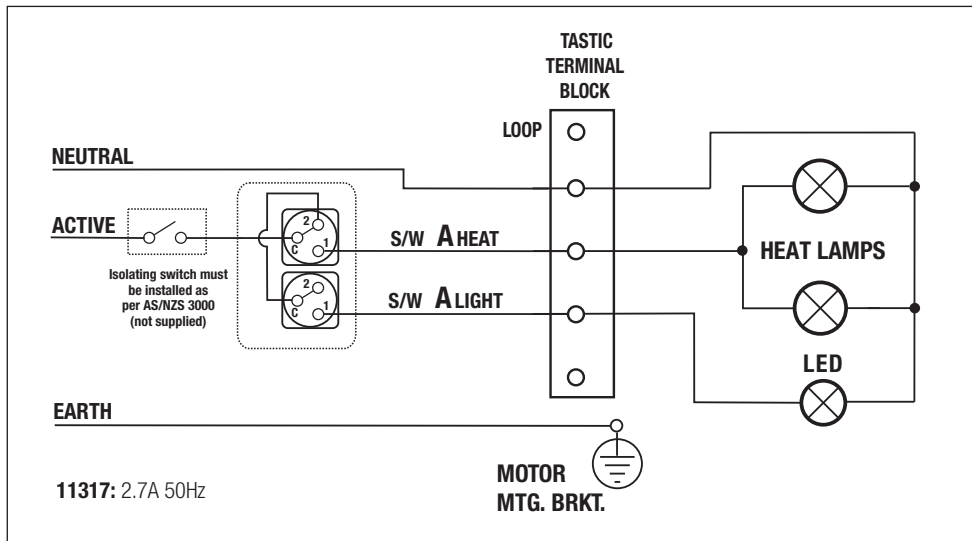

Fig. 8: Wiring diagram for model 11317.

Installation

The Tastic may be installed between joists using the inbuilt clip fasteners. Alternatively, the unit can be installed against a joist using two screws through holes located in the flange (Fig. 4 on page 7), provided that the clearances for the two vertical sides are maintained as per Fig. 3 on page 7.

Depending on your model, the Tastic has a weight of 2 – 3.5 kg (see below). If adequate support is not available for the Tastic, it may be necessary to provide extra strengthening.

Original – approx. 3 kg

Triumph/Mirage – approx. 2 kg

Sensation/Silhouette – approx. 3.5 kg

IMPORTANT: Joists, beams and rafters shall not be cut or notched to install the appliance.

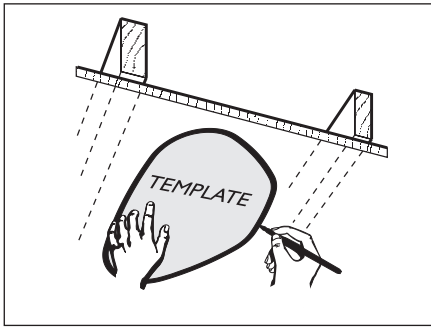

Fig. 9: Use template to mark position of Tastic

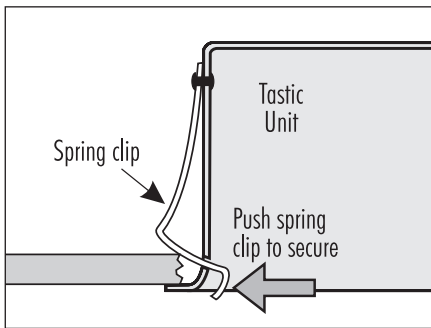

Fig. 10

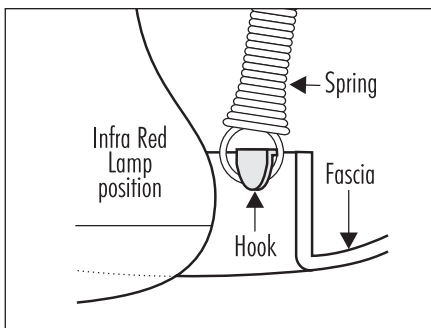

Fig. 11 – 11303, 11311, 11312, 11317 and 11335

NOTE: This product must be installed by a qualified installer. Ensure power is off to location of Tastic

1. After determining the location of the Tastic, use the card included with your Tastic Carton as a template to mark out and cut an aperture in the ceiling. Make sure that template is parallel to a wall
2. Remove fascia from the body. Remove all lamps, rubber band and switches from motor mounting channel. Spin fan to check freedom of rotation.
3. Unscrew terminal cover and make necessary wiring connections. Refit terminal cover. Do not turn on power to Tastic.
4. Push Tastic body into ceiling aperture, allowing metal springs to snap open. As the Tastic is raised into the ceiling, ensure electric cables do not rest over the Tastic.
5. To secure the Tastic in position, push lower ends of springs apart (Fig 10). Ceiling board thickness should be adjusted to enable springs to be fitted without excessive force.

Final Assembly

1. Models 11303, 11311, 11312, 11317 and 11335, remove lamps and centre globe to fit fascia into position and hook coil-spring onto fascia as per Fig. 11. Models 12301 and 12303 have snap fit fascia, however the lamps and centre globe must be fitted in these models prior to the fascia. The legs of the lamp surround must rest freely on the ceiling. A clearance of approximately 3-5 mm should exist between the ceiling and outer rim of surround.
2. Insert infra-red lamps and centre globe into socket and screw in well to give good electrical contact to ensure correct operation.
3. Centralise fascia and wipe surround and bulbs clean.
4. Turn on power and check operation of Tastic.

The Sensation and Silhouette fascia must be removed prior to replacing lamps. Ensure lamps are screwed well in after replacement to give good electrical contact.

NOTE: Replacement with any other lamps other than those listed below may cause damage to the moulding and void the warranty.

Heat Lamps

The IXL Tastic lamps have been specially developed for best performance.

11303 Original 275 watts max IXL Cat no. 11300

11311 Triumph 275 watts max IXL Cat no. 11300

11312 Triumph 375 watts max IXL Cat no. 11375

11317 Triumph 275 watts max IXL Cat no. 11300

11335 Mirage 275 watts max IXL Cat no. 11300

12301 Silhouette 375 watts max IXL Cat no. 11375

12303 Sensation 275 watts max IXL Cat no. 11300

NOTE: Replace only with genuine IXL approved Hard Glass Infra-Red lamps.

Light Bulb

R63 8W LED (IXL Model no. 12214) - suits Tastic Original and Tastic Prime.

R80 10W LED (IXL Model no. 12281) - suits most of the models except Tastic Original and Tastic Prime.

R80 10W Motion Sensor LED (IXL Model no. 12283) - suits most of the models except Tastic Original and Tastic Prime.

Light bulb is not covered by manufacturer's warranty.

NOTE: 100 W maximum light bulb on all model Tastics excluding Tastic Original and Tastic Prime – 42 W max.

Cleaning & Maintenance

WARNING: Always make sure the unit is turned off and allow all bulbs to cool before cleaning.

Maintenance of the Tastic is required to ensure the quality of the product and functions are maintained.

It is recommended that the Tastic body, fascia and globes be checked and cleaned every 2 years.

To clean bulbs and fascia use a damp cloth with liquid glass cleaner. Facia are dishwasher safe.

Cleaning and maintenance will help to preserve the lifespan and performance of the Tastic.

Service

NOTE: Do not remove the Tastic from the ceiling. Your Tastic will be serviced in your home. If service is required, please contact IXL's Customer Service on 1300 727 421.

Frequently asked questions

Q – Will my Tastic heat my bathroom?

A – No, your Tastic is designed to provide infra red radiant heat to warm the body while drying, when standing directly underneath. It is not designed as a room heater.

Q – Can I install my Tastic directly above a shower recess?

A – For safety reasons it is not recommended to install above shower recess. Please refer to the current Australian/New Zealand Wiring Rules AS/NZS 3000 relating to damp situations for further details.

Q – Can I replace by 275 watt heat lamps with 375 watt lamps?

A – You can only use heat lamps which have been fitted and approved for use in your product. The rating label will state the maximum wattage for your product.

Q – What is the maximum recommended light globe wattage that I can install in my Tastic?

A – Check the rating label for the maximum safe wattage for your product.

Q – What will happen if I leave my heat lamps on without fan operation?

A – On certain models (Eco & Easy Duct) the fan will commence operation automatically to keep the unit operating at a safe temperature. When the unit has cooled sufficiently the fan will switch off automatically. While the heat lamps of Classic Tastic models will operate normally when the fan is off.

Q – Why is my Tastic making noise?

A – All Tastics create some noise due to the rapid movement of air through the Tastic.

Q – Can I retro fit a remote control to my existing hardwired Tastic?

A – No, unfortunately this is not possible.

Q – My Tastic unit's extraction fan doesn't seem to be removing all the moisture and steam from my bathroom?

A – There are a number of factors that will influence the exhaust fan's performance. Firstly you can improve your cross ventilation via an open door or window; refer to page 6 of the instructions for details on improving the room's air flow.

If you live in a traditionally cooler climate, in the winter months during hot showers, you may notice that there is more moisture and condensation build up. If this is the case, you may wish to improve your natural ventilation or invest in an additional exhaust fan.

Bathrooms which have high ceilings, are larger than average, or have an open shower may all require additional ventilation. We recommend that you visit our website for further details and suggestions on effectively ventilating your bathroom.

Q – Can the installer rotate the IXL wall switch mechanisms?

A – Yes, the wall switches can be rotated by a qualified electrical trades person.

Q – Can my installer use an alternative wall switch mechanism other than the one supplied with my IXL product?

A – Yes, your authorised installer can use an alternative switch mechanism.

Q – Why is the motion sensor LED globe always ON?

A – Check whether the switch on the motion sensor LED globe is in the OFF position. If so then set the switch to the ON position to change LED globe to motion sensor mode. Make sure your light switch on the wall switch is in the ON position.

Q – Why is the motion sensor LED globe always ON when the fan is working?

A – It's most likely the motion sensor LED globe has detected movement in the fan impeller

Q – Why is the motion sensor LED globe on when there is nobody in the bathroom?

A – The motion sensor LED globe detection range is between 3-5 meters and may react with movement when someone is in this proximity.

If the functionality of the motion sensor globe causes an inconvenience, you can set the switch on the LED motion globe to the OFF position and use it as standard LED globe.

- Q** – Why does the motion sensor LED globe switch ON then OFF for 2-3 seconds every time I turn the light switch ON at the switch plate?
- A** – It is because the LED globe reverts to the motion sensor mode. The first 2-3 seconds ON to OFF is the signal to program the PCB inside the LED motion globe. This is not considered a fault, the LED globe will perform this way whenever the light switch on the wall is switched to the off position.

For more information or help, please contact IXL Home.

IXL Tastic® Warranty

This Warranty against defects for your newly purchased Tastic product is proudly prepared by IXL Home Pty Ltd of 1K Marine Parade, Abbotsford, VIC 3067, phone 1300 727 421.

1. (i) Where your product was purchased in Australia, IXL Home Tastic products come with guarantees that do not exclude the following consumer entitlements under the

Australian Consumer Law:

- a. replacement or refund for a major failure and compensation for any other reasonably foreseeable loss or damage; and
- b. to have the goods repaired or replaced if goods fail to be of acceptable quality and the failure does not amount to a major failure.

(ii) Where your product was purchased in New Zealand, IXL Home products come with guarantees that do not exclude consumer entitlements under the **New Zealand Consumer Law** and IXL Home will replace the product with a new or equivalent current model free of charge or , or repair the product at our cost, at our discretion.

2. IXL Home warrants that your product and related supply will be free from defects in materials and workmanship during the warranty term. Your in home warranty term is five years with a two year heat lamp and inline fan replacement warranty, commencing from the date of purchase. IXL Home acknowledges this product requires professional installation and product removal is hazardous to consumers, accordingly any necessary inspections and services will be carried out on site. You should not attempt de-installation.

3. Subject to Point 1, IXL Home will repair any defects in materials and workmanship during the warranty term and if the product is deemed irreparable provide a replacement of an equivalent current model where the balance of the warranty period from the original date of purchase will take effect.

4. To the fullest extent permitted by law and subject always to Point 1, IXL Home will not be liable for:

- a. any loss or damage arising from loss of use, loss of profits or revenue; or
- b. for any indirect or consequential loss or damage resulting from any breach of this warranty against defects.

5. Defective IXL Home Tastic products may be repaired using refurbished parts or if required, completely replaced by a refurbished product of the same type.

Limitations to Your IXL Tastic® Warranty

6. Subject to Point 1, this Warranty:

- a. will only be provided to the original purchaser where the original purchase was made from a IXL Home Authorised Dealer or Reseller and proof of such purchase can be presented at the time of

service;

b. only applies to IXL Home Tastic products purchased in Australia from a IXL Home Authorised Dealer or Reseller and installed by a qualified person where a Certificate of Compliance in accordance with State/Territory laws is provided;

c. will not apply where the defect in or failure of the product is attributable to misuse, abuse, accident or non-observation of the manufacturer's instructions. This product must be used in accordance with the manufacturer's instructions;

d. will not cover faults due to normal wear and tear with reasonable use nor consumable components such as globes, filters, glass items, etc;

e. will not cover any damages or problems caused to this product by natural forces e.g. storm, fire, flood, and earthquake; or by intrusion or accumulation (or both) of foreign matters e.g. dust, soil, and moisture. IXL Home recommends that you take out appropriate insurances to protect your product to this end;

f. will not apply if this product is installed in a mobile dwelling e.g. caravan or boat;

g. will not apply if this product is removed from the location where it was first installed;

h. is immediately void if the serial or model number label is removed or defaced;

i. is immediately void if the product is serviced or repaired by an unauthorised/unqualified personnel;

j. covers use of this product for domestic use only;

k. will not be restarted or extended upon repair or replacement of the product or a part.

How to make a Claim under Your IXL Warranty

7. To make a claim under this Warranty you will need to:

a. contact IXL Home customer service team to provide details and register your claim enabling an assessment;

b. submit proof of purchase with your claim e.g. tax invoice or purchase receipt;

c. where a property has been constructed by a builder/developer and it is fitted with IXL products, please submit proof of purchase by way of the certificate of occupancy, with your claim.

8. IXL Home will contact you to make arrangements for service on site.

9. Subject to Point 1, you will be responsible for any costs relating to the provision of your product to a IXL Home Authorised Service Dealer.

10. Subject to Point 1, in the event you live more than 50 km from a IXL Home Authorised Service Dealer you may be subject to travel or transport costs to facilitate the repairing or replacement of your IXL product.

11. IXL Home and its Authorised Service Dealers reserve the right to seek reimbursement of any costs incurred by them should your IXL product be found to be in good working order.

Privacy

The privacy of your personal information has always been important to us. To learn more about how we collect, keep and use your personal information, please obtain a copy of our privacy statement by visiting our website.

Notes

Tastic

Warranty Registration



Visit the IXL Home website below to register your warranty details online.

Australia

www.ixlappliances.com.au/warranty

New Zealand

www.ixlappliances.com.au/warranty

For comments, questions or warranty matters:

IXL Home Pty Ltd

Australia:

1K Marine Parade,
Abbotsford VIC 3067, Australia
Free Call: 1300 727 421
service@ixl.com.au
www.ixlappliances.com.au

New Zealand:

Free Call: 0800 727 421
service@ixl.com.au
www.ixlappliances.co.nz

© Copyright IXL Home, 2021



Approved by the appropriate electrical supply authorities.