

4 SHELF GALVANISED STORAGE UNIT

Tools Required

Phillips Head battery powered screwdriver, Phillips Head Screwdriver, Pliers or Adjustable Spanner.

WARNING: Handle cut metal edges carefully. We recommend wearing gloves whilst assembling this unit.

List of Parts

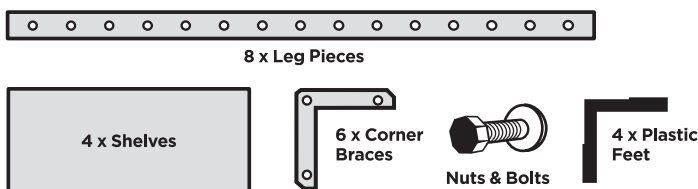

Assembly Instructions

1. Turn one shelf upside down and using only one nut and bolt for each Brace in holes as show in diagram (Pic 1) fix 6 corner Braces to the shelf. In two opposing corners connect 2 corner braces at right angles. In remaining corners position a single brace parallel to the longest edge (Pic 1).

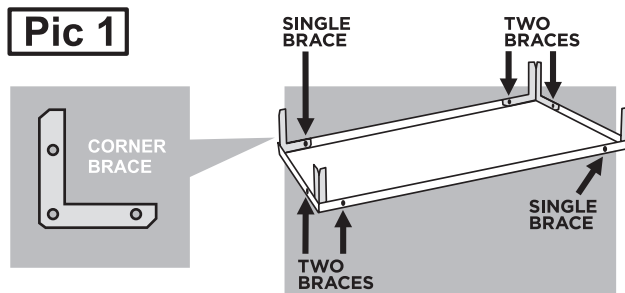

2. To make one full length leg, overlap 2 Leg Pieces and bolt them together. (You must overlap the first 2 holes of each Leg Piece). Do the same with the remaining Leg Pieces to make the 4 legs. Fit a Plastic Foot to each of the completed Legs (Pic 2).

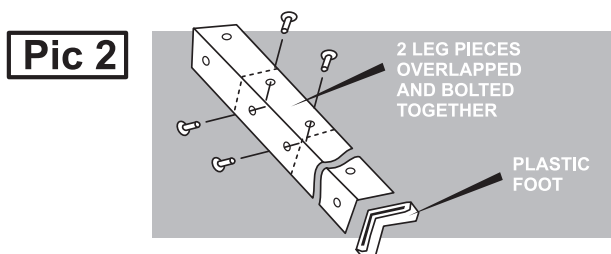

3. Refer Pic 3: (Note 3rd Shelf has the Corner Braces attached). Fit Leg to top Shelf (at the top hole of the leg). Then fit the bottom Shelf to the Leg at the 2nd hole from the bottom. Next fit the 2nd shelf (position is up to you). Finally, fit the 3rd Shelf (position is up to you).

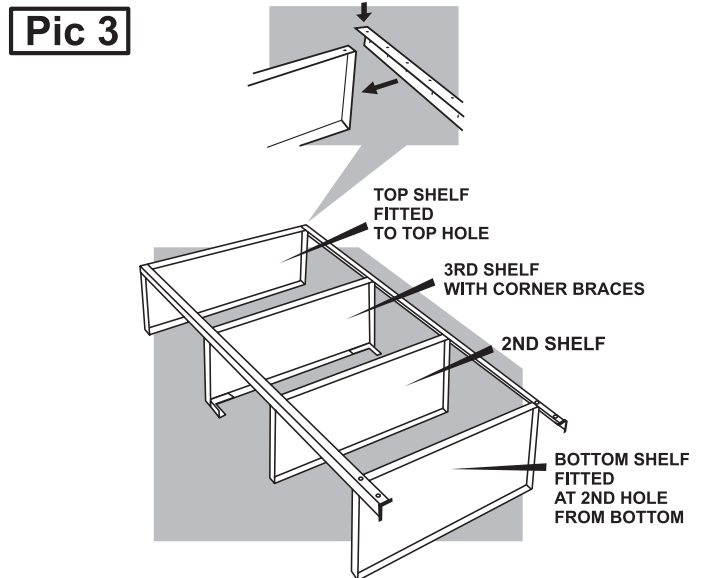

4. Flip the unit over and bolt on the 2 other Legs.
5. On a level floor make sure the Unit is square, then tighten all the nuts & bolts.



THIS PRODUCT SHOULD BE ANCHORED TO A WALL OR OTHER SUITABLE SURFACE TO AVOID SERIOUS INJURY OR DEATH.

To help avoid any serious or fatal injury, this product can be fastened to the wall using leg fixing points to prevent toppling. We strongly recommend that this product be permanently fitted to the wall or other suitable surface. Fixing devices are not included since different surface materials require different attachments. Please seek professional advice if you are in doubt what fixing device to use.

WARNING CHOKING HAZARD: THIS PRODUCT CONTAINS SMALL PARTS