

For construction in non-cyclonic areas

Wind rating: "N2" as per AS4055-2021
("Medium M" to NZS3604-2011)

If you require a higher wind rating please contact us:
admin@absco.com.au or 1800 029 701

NOTE: This shed can be upgraded to wind rating:
"C1" as per AS4055-2021 ("Very High VH" to
NZS3604-2011) with the addition of a Cyclone Kit.

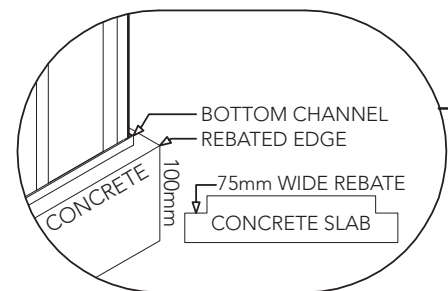

When laying concrete slab, ensure there is a rebated edge 25mm deep around the perimeter. This will help water egress from the base of the shed.

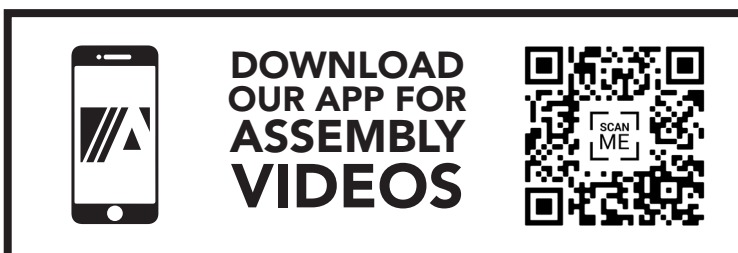

*Most models available

PLEASE LEAVE A REVIEW

Tell us about your experience!
Visit www.abscosheds.com.au/review

GENERAL INSTRUCTIONS

- Before commencing any assembly, read through these instructions in detail to gain a thorough understanding of assembly methods and associated details.
- Unpack the carton and carefully identify and check off all the parts against the parts described and illustrated on "COMPONENTS PACKING LIST" pages.
- Some drilling is required during assembly; Carefully clean away steel shavings (swarf) as you go. Use a soft brush or vacuum as you go to prevent damage to your shed.

SITE PREPARATION

- The site for the shed must be level. An uneven surface may result in misalignment of parts.
- The shed shall be erected on top of a reinforced concrete slab and anchored down appropriately illustrated on "FINAL CONSTRUCTION" page.

TOOLS REQUIRED

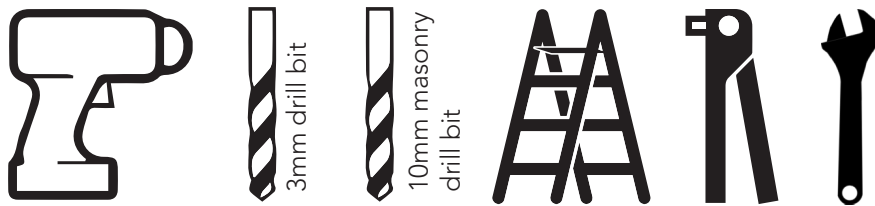

SAFETY NOTES









- Some parts may have sharp edges. It is advisable to wear gloves when handling these items and safety glasses if drilling holes. Sensible shoes are highly recommended.
- Do not erect your shed in windy conditions.
- Ensure that the shed is securely anchored to a solid foundation immediately after construction is completed.
- It is highly recommended to erect the shed with two or more people.
- Do not sit, stand or walk on the roof of your shed.

RECOMMENDED

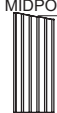
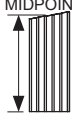

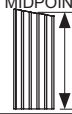
COMPONENT PACKING LIST

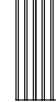















Check off all components.

QTY	COMPONENT DESCRIPTION	PART NO.	CHK	QTY	COMPONENT DESCRIPTION	PART NO.	CHK
2	 STEEL SHEET 2045mm X 773mm	262		1	 STEEL SHEET 1852mm TO MIDPOINT X 773mm	260L	
2	 STEEL SHEET 2045mm X 773mm	263		1	 STEEL SHEET 1852mm TO MIDPOINT X 773mm	260R	
1	 STEEL SHEET 1979mm TO MIDPOINT X 773mm	261L		4	 STEEL SHEET 1610mm X 773mm	43S	
1	 STEEL SHEET 1979mm TO MIDPOINT X 773mm	261R		2	 STEEL SHEET 1785mm X 711mm	34A	
1	 STEEL SHEET 1725mm X 773mm	A		1	 STEEL SHEET 1725mm X 773mm	B	

Nominal sheet widths are shown. +/- 2mm is within tolerance.







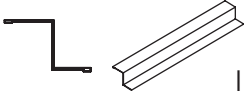
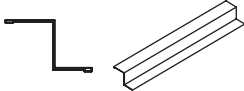
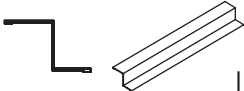
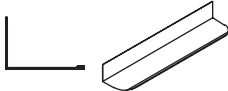
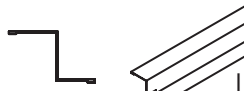
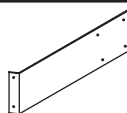
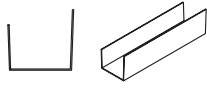
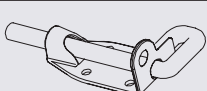
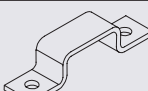

COMPONENT PACKING LIST

Check off all components.

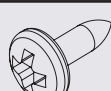
QTY	COMPONENT DESCRIPTION	PART NO.	CHK	QTY	COMPONENT DESCRIPTION	PART NO.	CHK
2	 CHANNEL L = 1496.5mm	81AL		2	 CHANNEL L = 1496.5mm	81AR	
2	 CHANNEL WITH HINGES L = 1725mm	58A		1	 CHANNEL L = 1725mm	58B	
4	 CHANNEL L = 773mm	58C		1	 CHANNEL L = 1568mm	79A	
2	 CHANNEL L = 1530mm	61D		2	 CHANNEL L = 1513mm	81E	
NOTCHED CHANNEL							
1	 CHANNEL L = 1496.5mm	55AL		1	 CHANNEL L = 1496.5mm	55AR	
1	 CHANNEL L = 1496.5mm	55CL		1	 CHANNEL L = 1496.5mm	55CR	
1	 CHANNEL L = 1496.5mm	55BL		1	 CHANNEL L = 1496.5mm	55BR	
1	 CHANNEL L = 1496.5mm	81BL		1	 CHANNEL L = 1496.5mm	81BR	

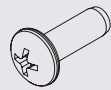
COMPONENT PACKING LIST

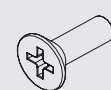
Check off all components.

QTY	COMPONENT DESCRIPTION	PART NO.	CHK	QTY	COMPONENT DESCRIPTION	PART NO.	CHK
2	 JAMB L = 1785mm	89A		1	 JAMB L = 1568mm	90A	
1	 JAMB L = 1725mm	89C		2	 LIP TRIM L = 1610mm	88J	
4	 JAMB L = 1120mm	91A					
INSTRUCTION & FITTINGS PACK							
2	 DOOR STRAP L = 165mm	12A		6	 CHANNEL JOINER L = 200mm	CSJ	
1	ASSEMBLY INSTRUCTION MANUAL			1	DOUBLE DOOR FITTINGS PACK	PSTK DBL	
PSTKDBL - DOUBLE DOOR FITTINGS PACK							
3	 DOOR PADBOLT	FAST 006		2	 PADBOLT HASP	FAST 007	
1	 3mm DRILL BIT	DRILL		1	 PHILLIPS DRIVER BIT	FAST 038	
1	 8G x 3/8" SELF TAPPING SCREW FAST001	PACK 220		12	 3.2x8mm BLIND POP RIVETS	FAST 009	
8	 3/16" ROUND HEAD BOLT	FAST 002		8	 3/16" ROUND NYLOC NUT	FAST 003	
12	 3/16" COUNTER SUNK SCREW	FAST 004		12	 3/16" NUT	FAST 005	

SNAPTITE ASSEMBLY GUIDE

The Snaptite Assembly System locks end channels to all roof and wall sheets without the need for tools and fasteners.

To assemble each panel, the perimeter channels are secured to the top and bottom of each panel. Gently tap the channel over the SNAPTITE lugs on the sheet, working along the sheet.

Each perimeter channel must finish flush with the edges of the sheets. Simply tap the channel along the sheets until each end is neatly flush. If you need to remove channels from the panels, slide it off from the side.

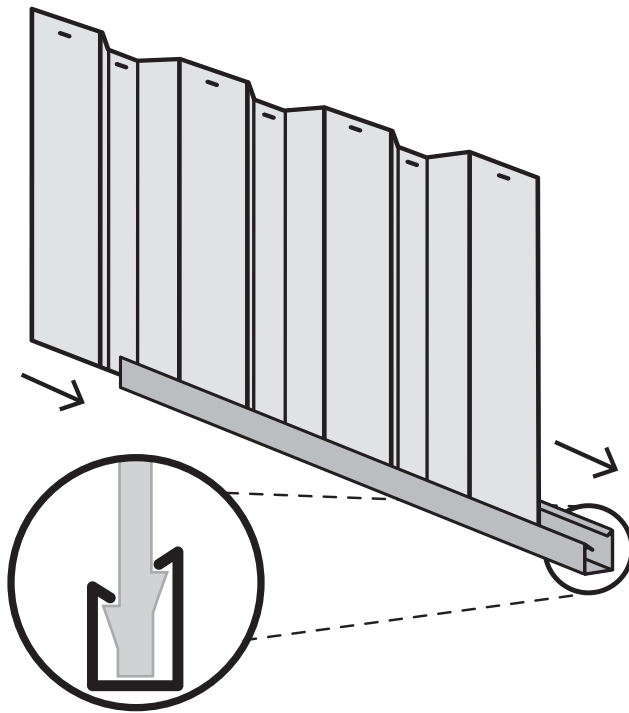

SNAPTITE
World's Easiest Assembly System
UNIQUE PATENTED SYSTEM

Channel locks the shed panel into position without the need for screws!

FASTENING SYMBOLS

 SNAPTITE

Secure channel to sheeting by SNAPTITE fastening method.



Join components together with one screw at this location only, as some channels have extra holes that are not required for this model of shed.

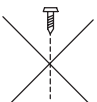

Do not join components together at this location yet, as the screws may obstruct further assembly of the other components.



Join components together by pre-drilling the holes first. Use one component as template to mark where the holes are and drill with a 3mm drill bit.



3mm pop rivet



4mm nut and bolt set.

Guide on Joining Spliced Channels

The text marked on all parts must be shown on the same side as each other



Step 1.
Position the channels and the CSJ joiner so the centre of the CSJ is in line with the ends of both channels as shown.

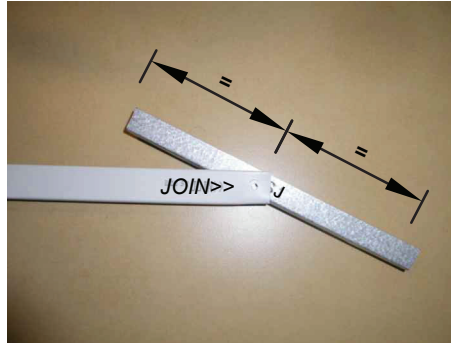

Step 2.
Join the first channel to the CSJ by inserting the centre of the CSJ, on an angle, to the end of the channel where the JOIN>> text is marked.

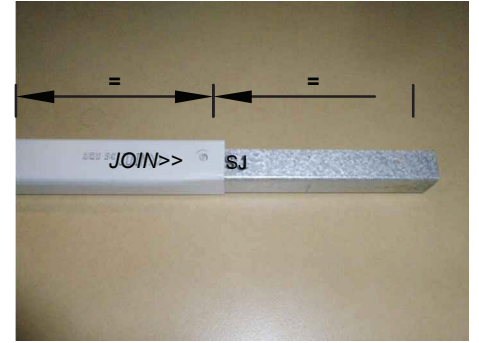

Push down one side of the CSJ until you hear a 'click'.

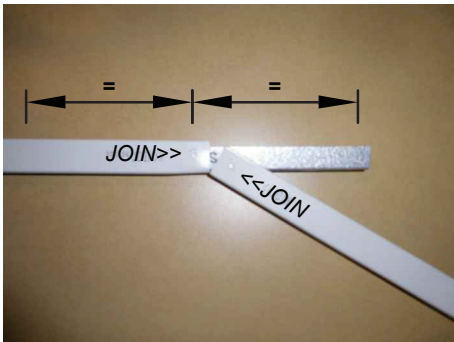

Step 3.
Join the second channel to the CSJ by positioning the <<JOIN of the channel at the centre of the CSJ, on an angle. Push the CSJ into the channel until you hear a 'click'.

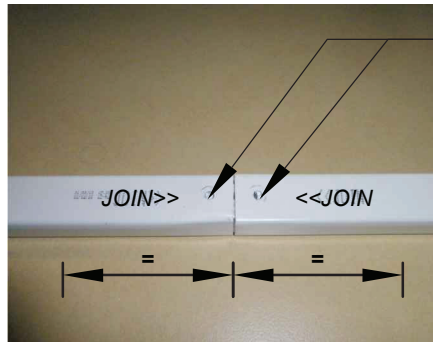

Finished Channel.
The joined channels should now look like the picture with the CSJ positioned equally inside of the joined channels.

Drill out holes with 3mm drill bit in CSJ to match the holes in channel. Drilling of screws on the joined channels is being done after sheets are locked on the spliced channels.

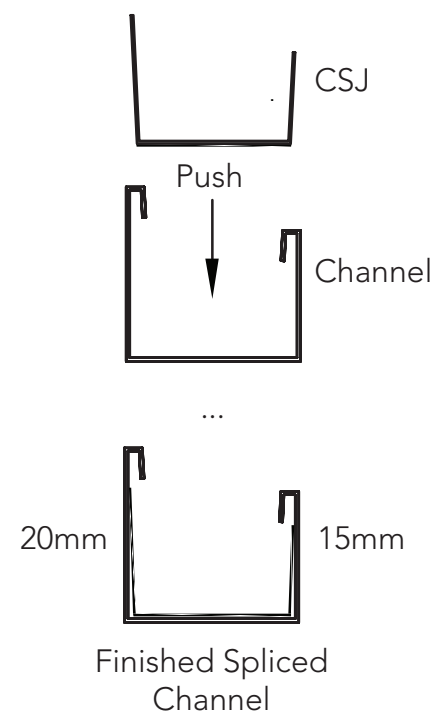

PRE-ASSEMBLY OF SPLICED CHANNELS

Join together 12x channel sections using 6x channel joiners (Part CSJ)

NOTE: Some channels may have holes in them - You will need to redrill holes where CSJ joining channel covers them.

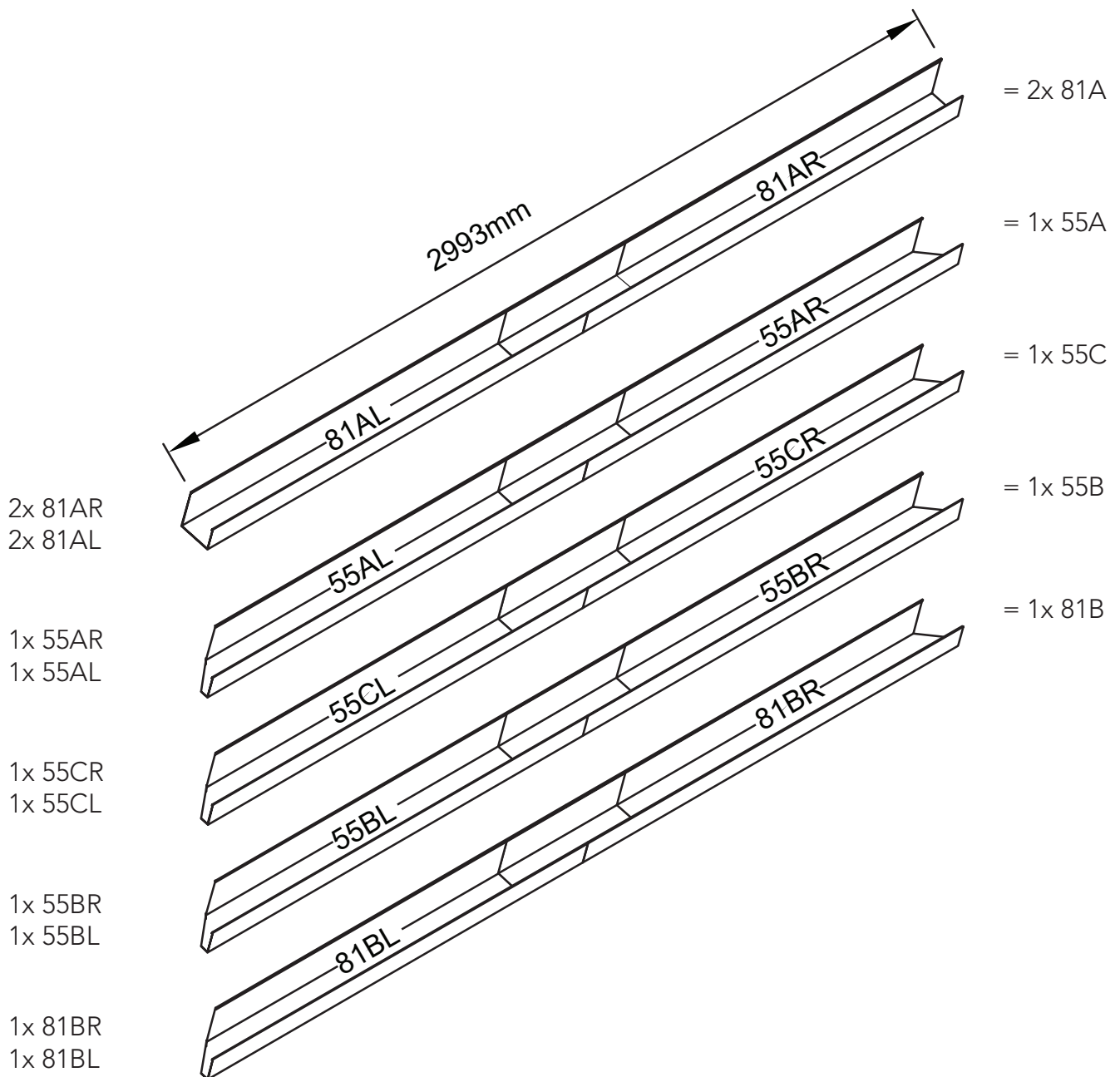

OVERVIEW OF ROOF COMPONENTS

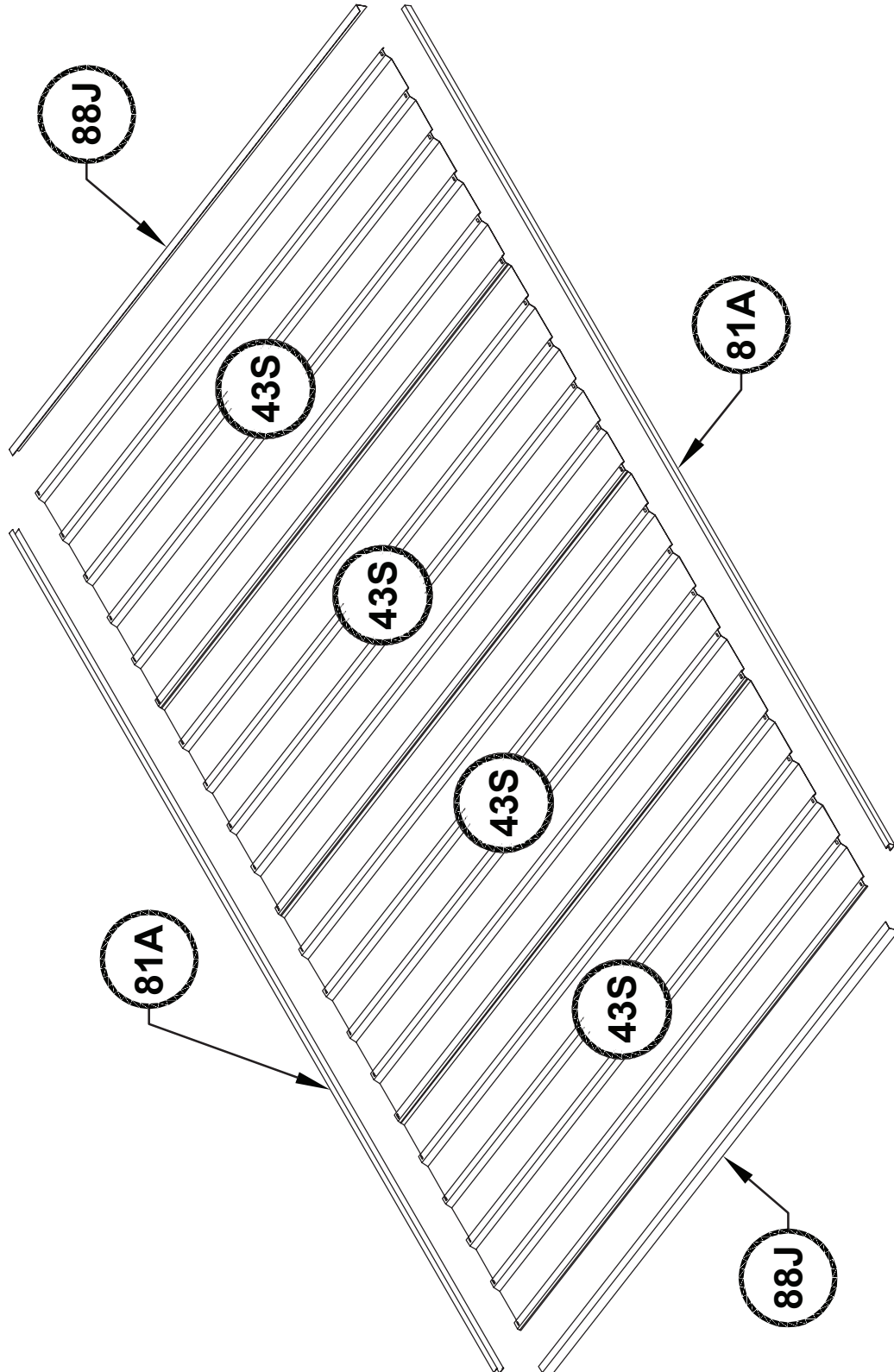

OVERVIEW OF ROOF COMPONENTS

OVERVIEW OF WALL COMPONENTS

OVERVIEW OF WALL COMPONENTS

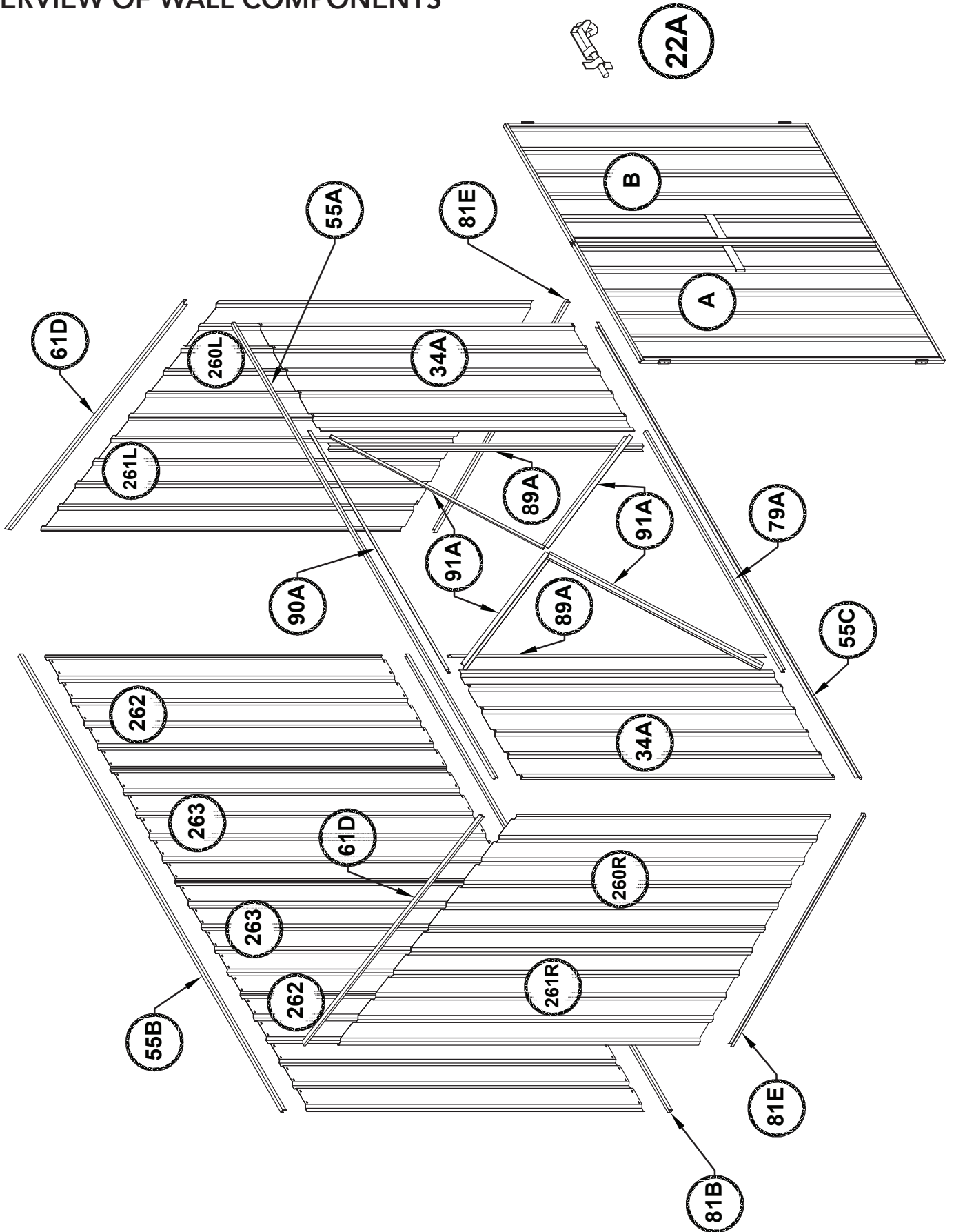

REAR PANEL ASSEMBLY

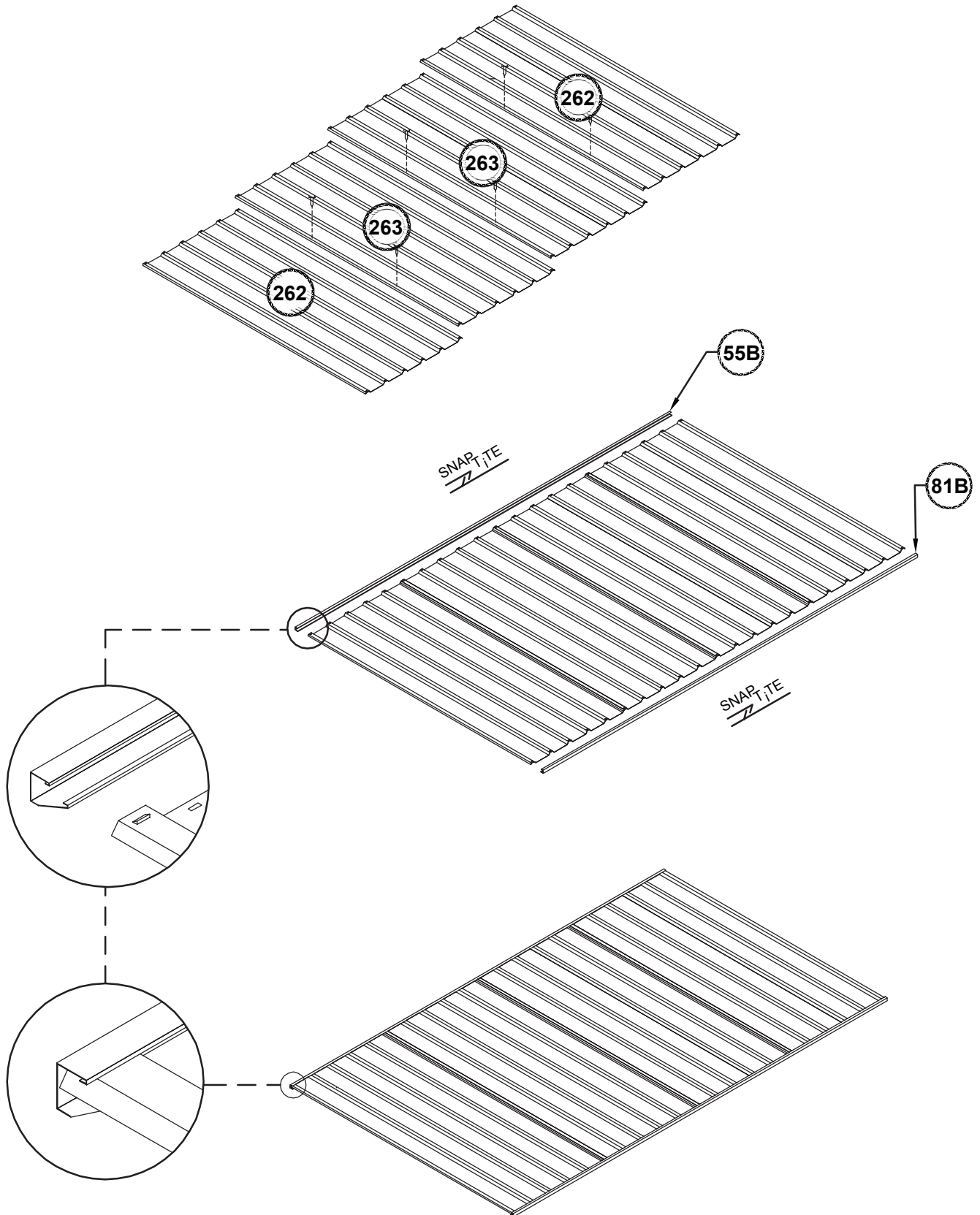

SIDE PANEL ASSEMBLY

1x LEFT SIDE PANEL
1x RIGHT SIDE PANEL

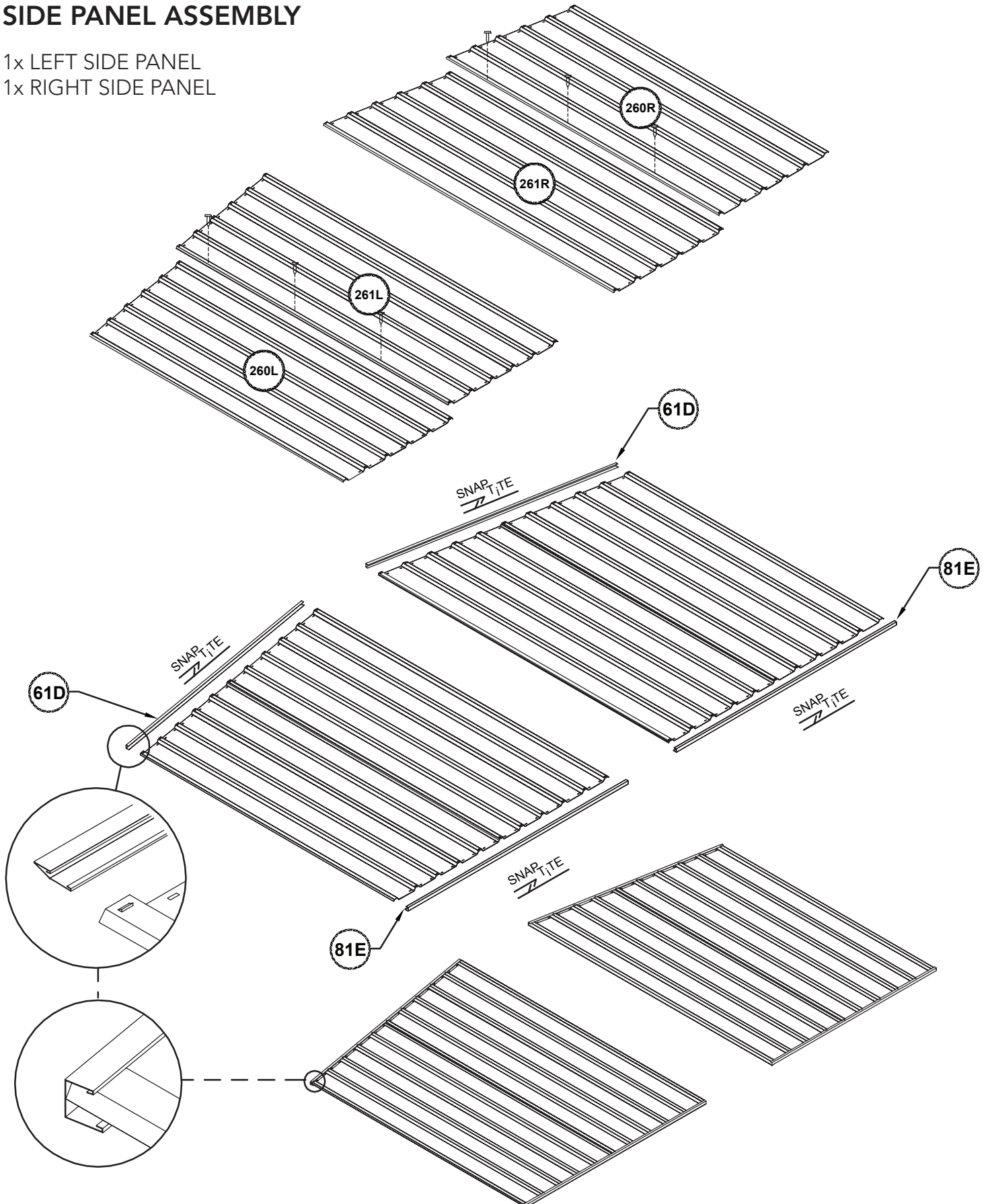

ROOF PANEL ASSEMBLY

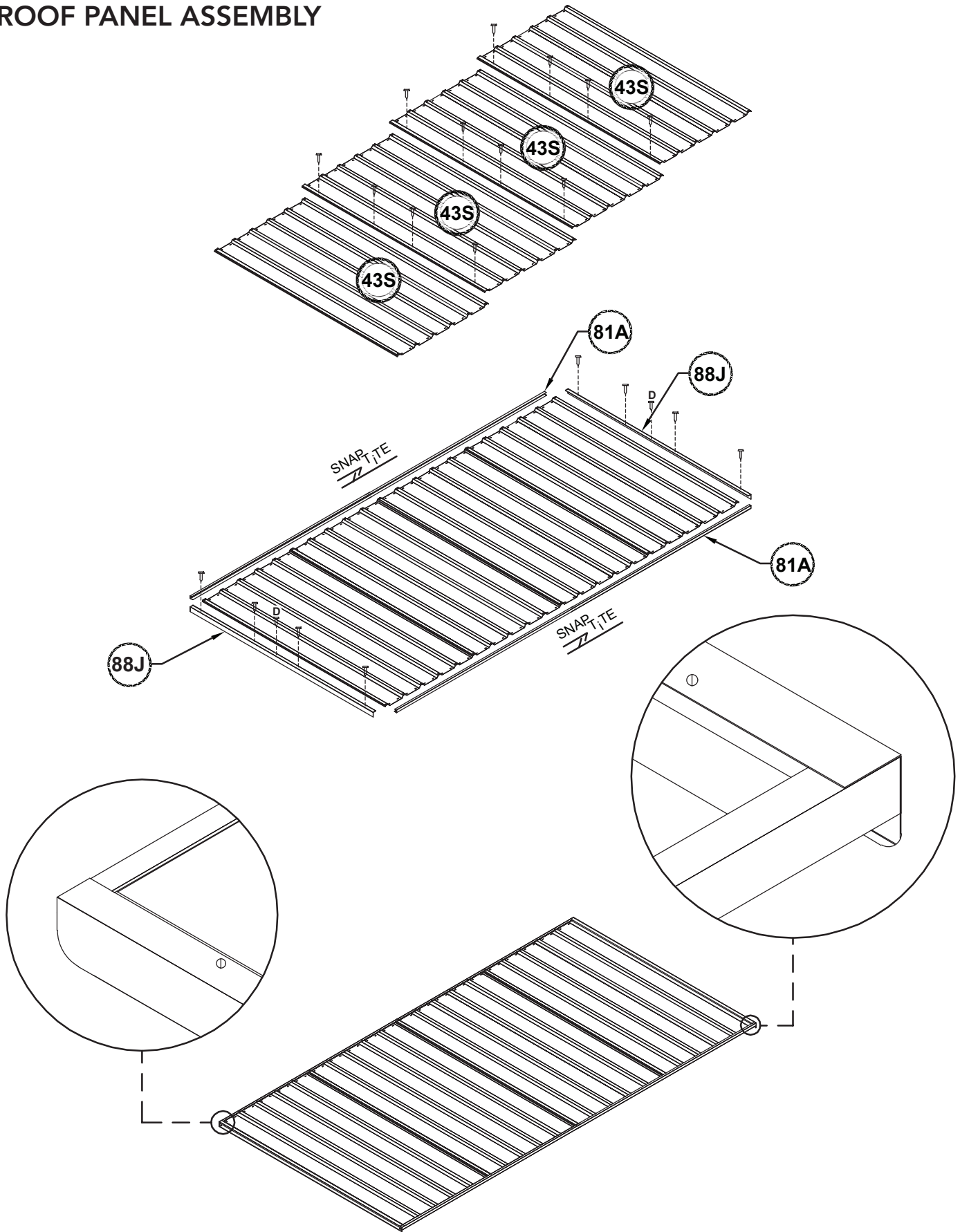

FRONT PANEL ASSEMBLY

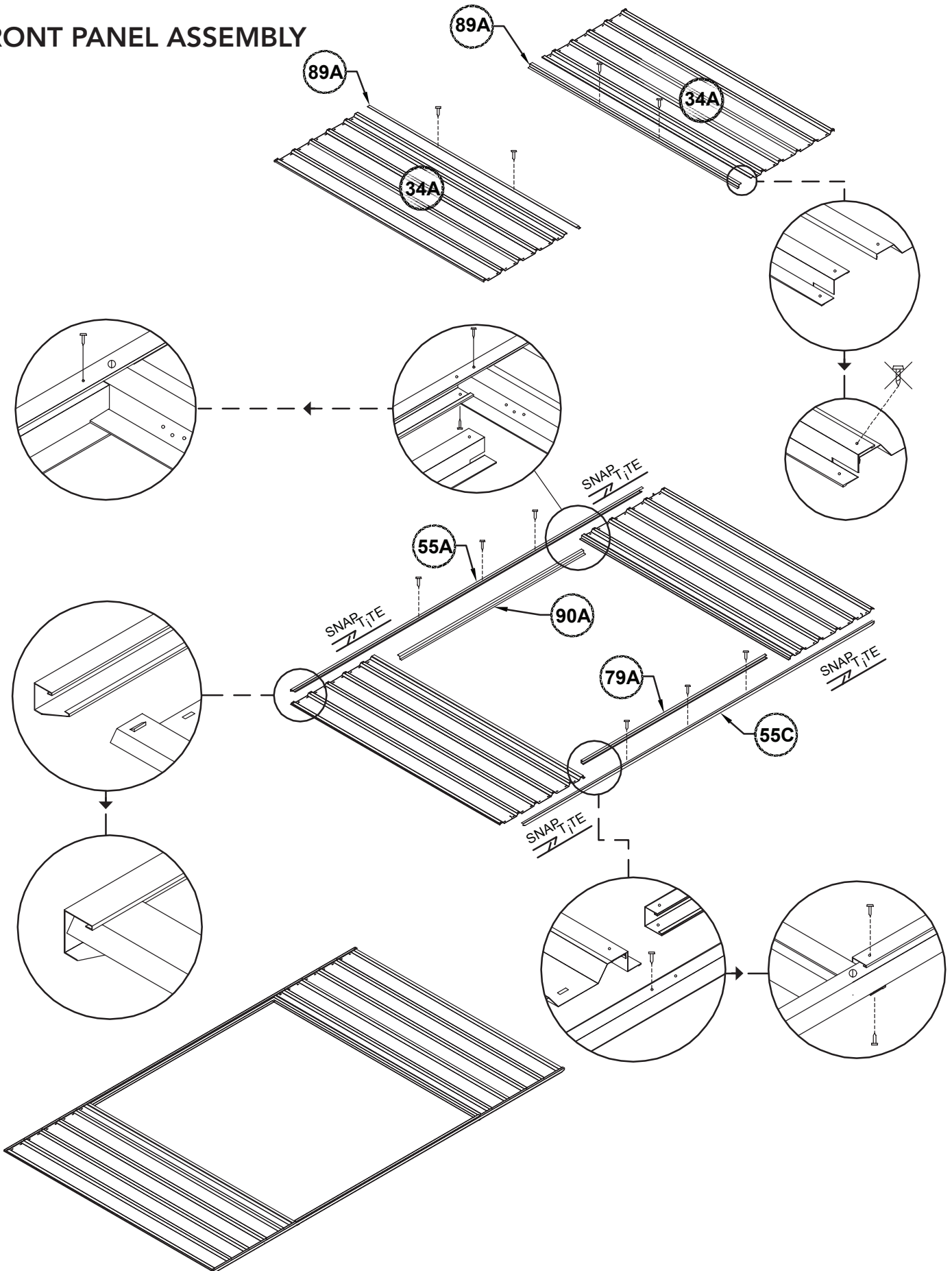

DOOR PANEL ASSEMBLY

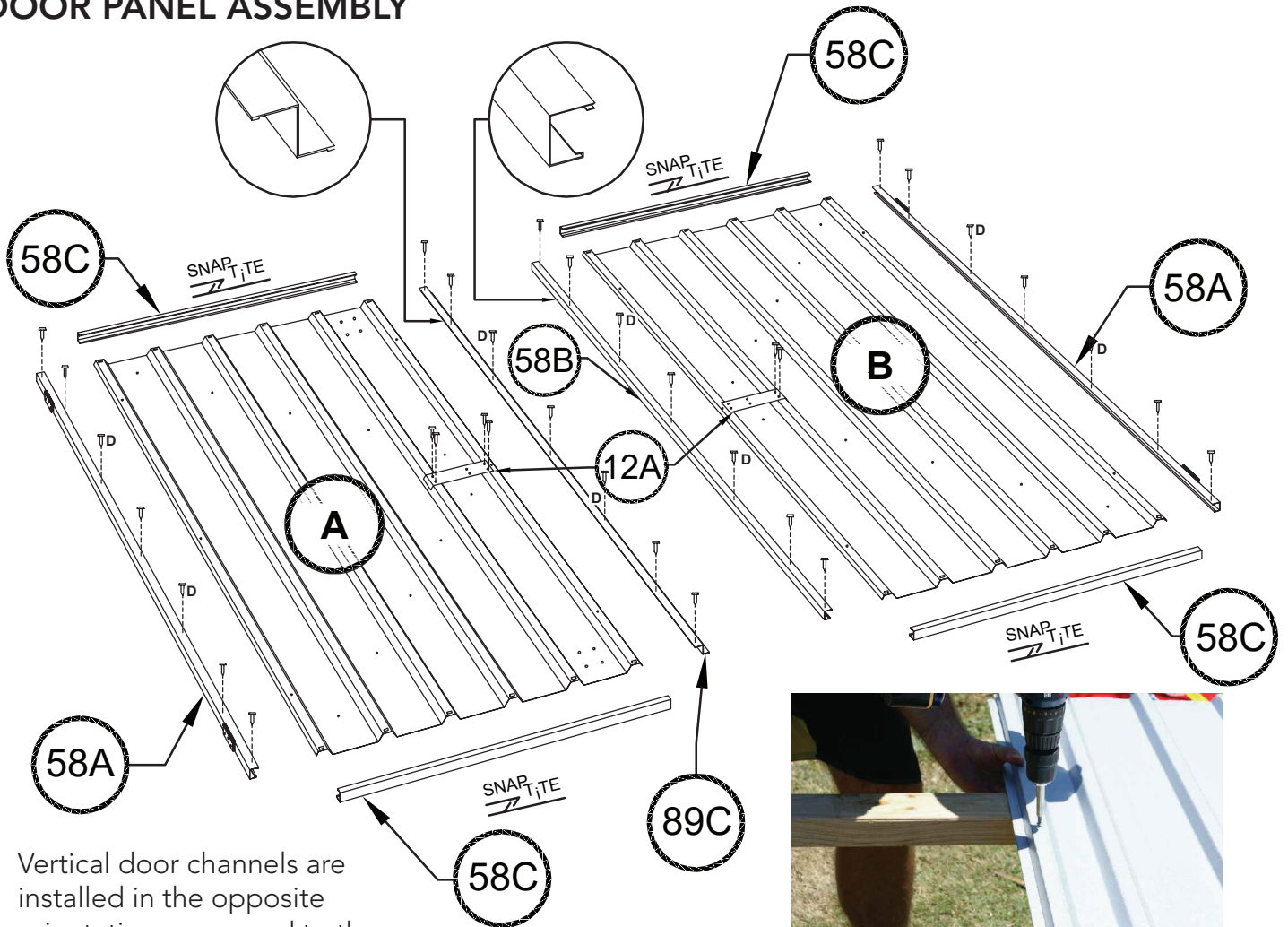

Vertical door channels are installed in the opposite orientation compared to the horizontal door channels.

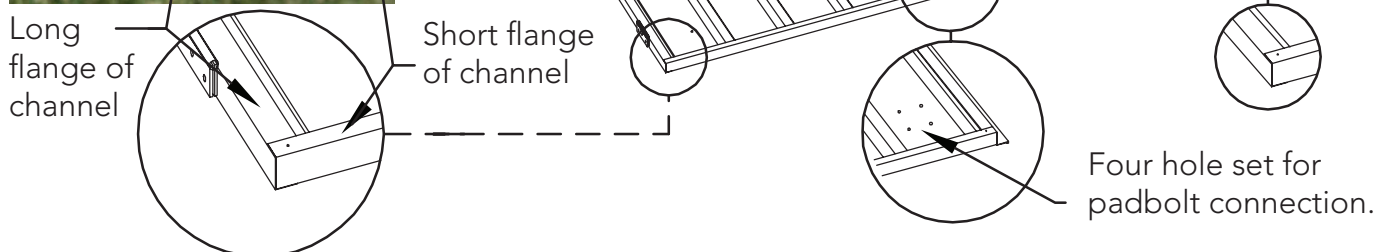
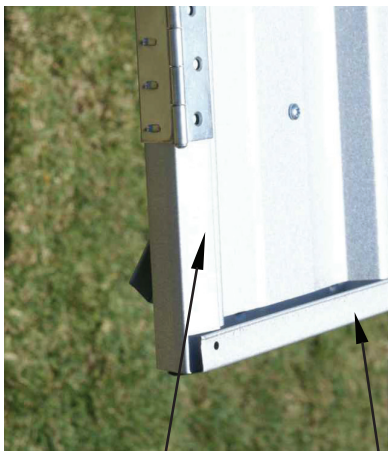

DOOR PANEL ASSEMBLY

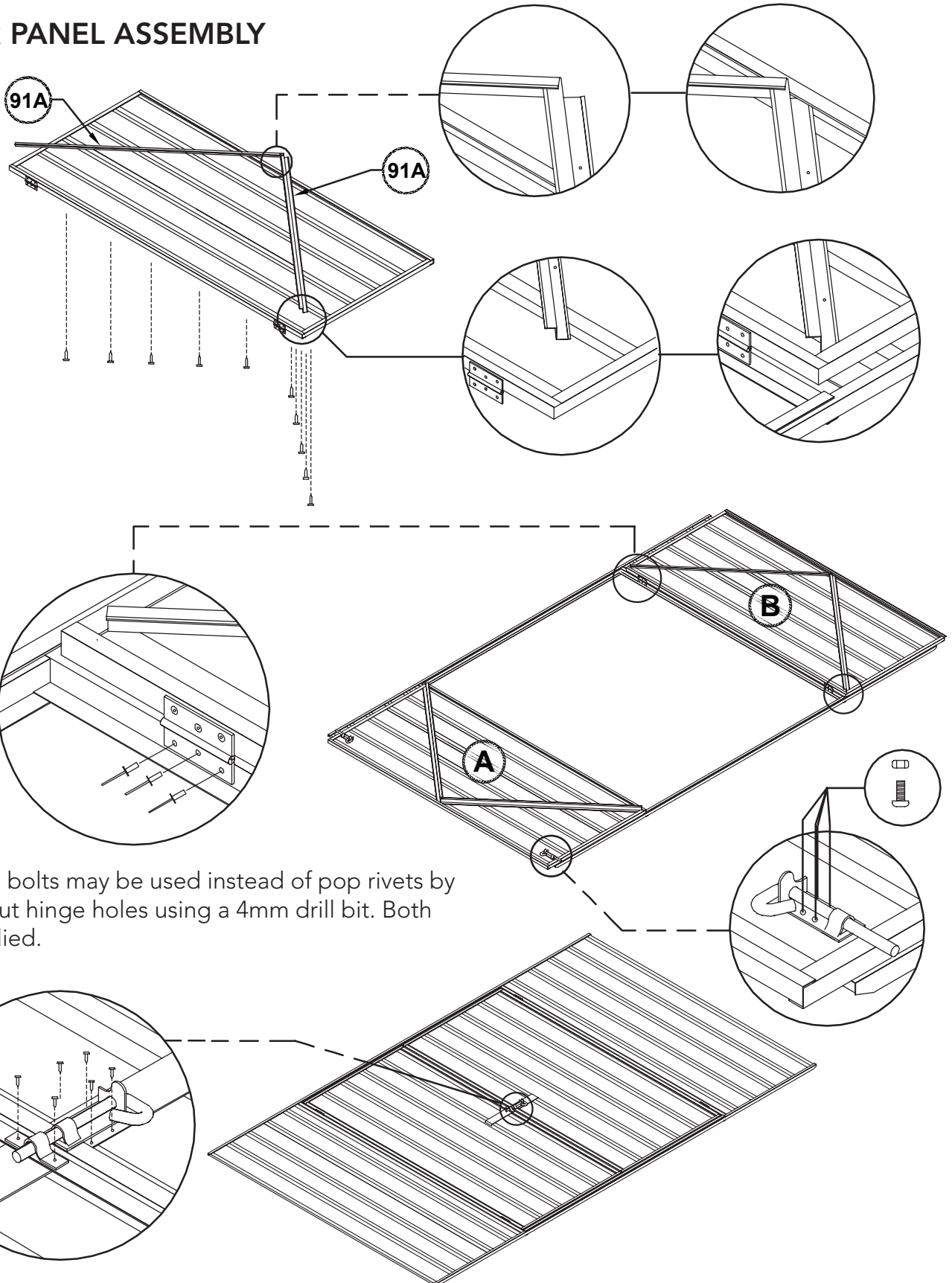

Nuts and bolts may be used instead of pop rivets by drilling out hinge holes using a 4mm drill bit. Both are supplied.

The two holes required to connect the padbolt hasp for each door have not been pre-punched, to allow for proper alignment, position each hasp centrally over the padbolt shaft and drill 3mm holes and secure with screws.

PANEL CONSTRUCTION

NOTE: Take care to ensure that all wall panels are not upside down. The top channels of each panel are pre-punched for attaching roof sheeting. The base channels are not pre-punched.

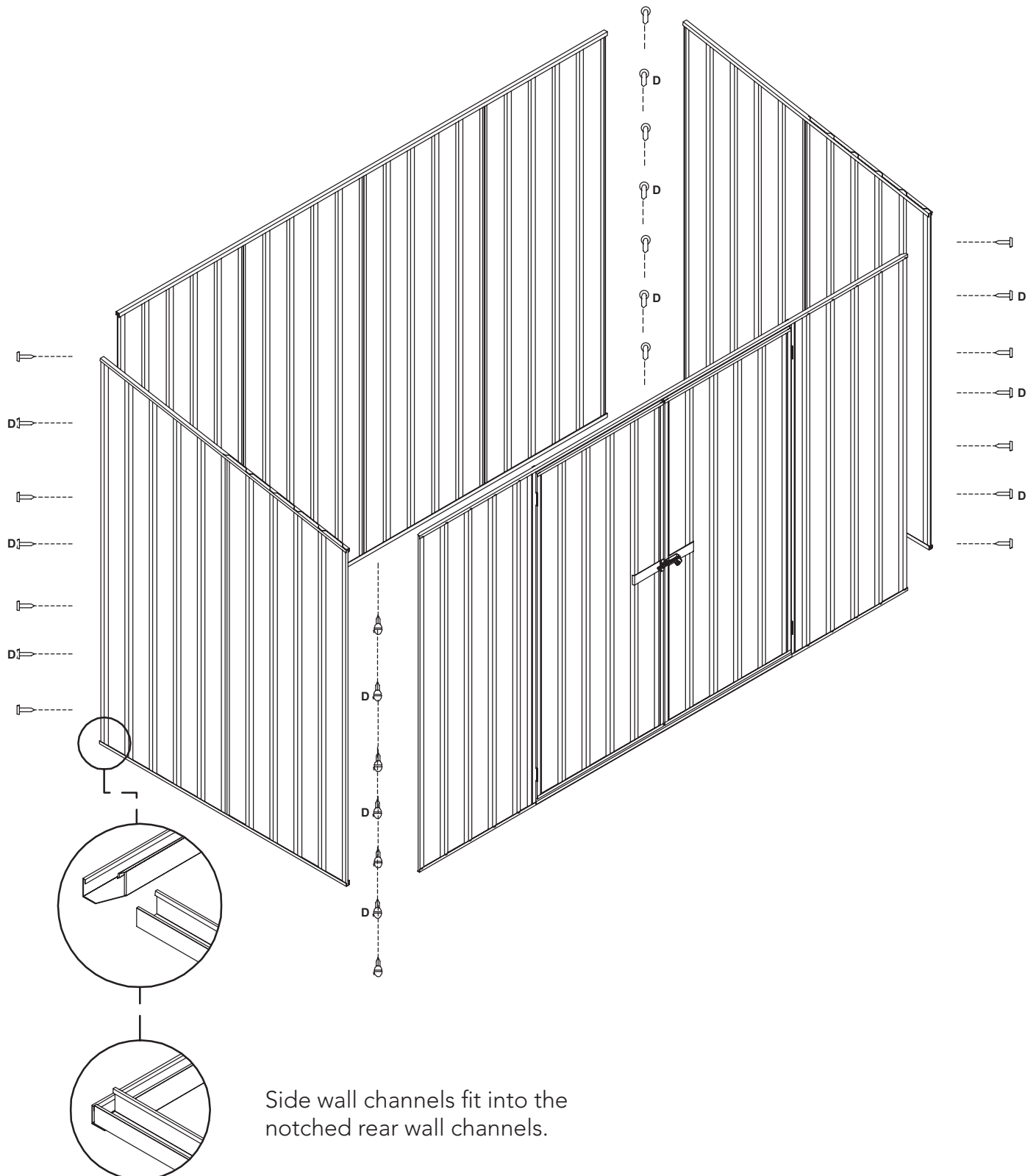

FINAL CONSTRUCTION

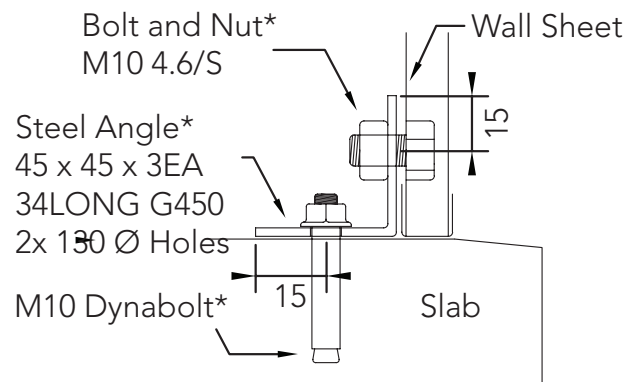
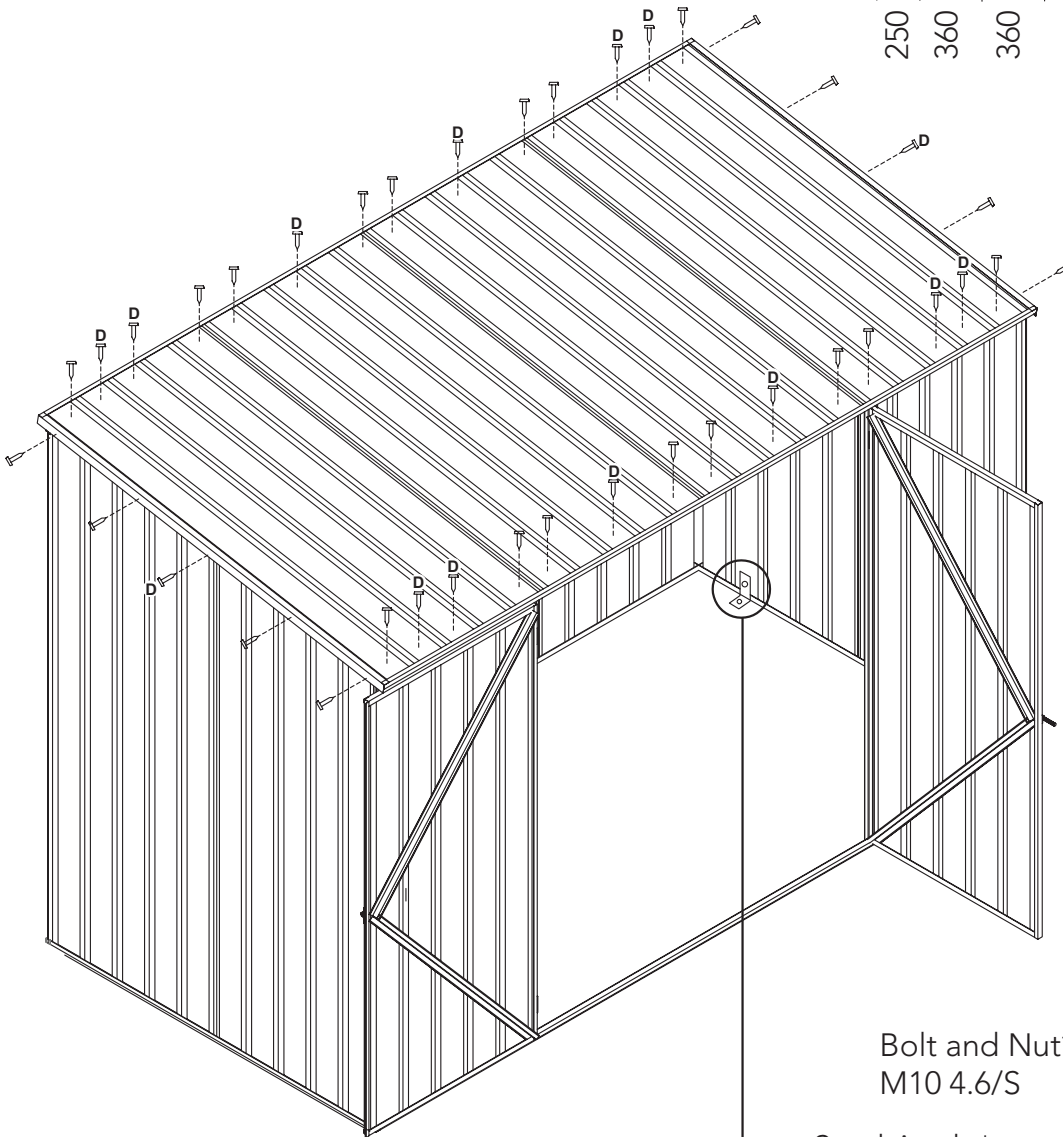
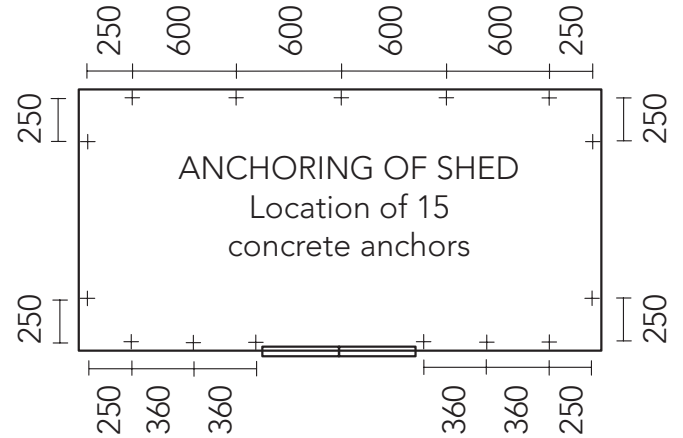

Each anchor consists of one nut, bolt, M10 dynabolt and steel angle.
Drill a 10mm hole into the wall sheet.
Drill a 10mm hole into the concrete.

* Denotes hot dip galvanised finish

Absco Skillion Roof Shed Notes

General

- 1.G This instruction manual shall be read in conjunction with other consultants drawings, specifications and written instructions provided by Absco and/or their representatives.
- 2.G The drawings provided herein are for installation and structural engineering purposes only. If discrepancies are discovered within the documentation provided, these shall be brought to the attention of Absco and written approvals obtained prior to commencing the affected section of work.
- 3.G If in doubt ask.
- 4.G Until approvals from the local authorities are obtained, commencement of construction from these drawings shall not commence.
- 5.G Unless varied by the project specification, all materials and workmanship shall be undertaken in accordance with the relevant Australian standards and the by-laws and ordinances of the relevant building authorities.
- 6.G All dimensions indicated in these drawings shall be verified on site by the installation contractor. Scaling of drawings shall not be undertaken.
- 7.G Prior to commencing works on site, the contractor shall verify the position of all services in the area to ensure that the construction does not interfere with any of those services.
- 8.G During installation on site the shed structures shall be maintained in a stable condition with no part becoming overstressed or permanently deformed.
- 9.G In circumstances where the shed has been installed in a manner which is inconsistent with the installation manual, structural certification shall be void.
- 10.G The structural components detailed within this installation manual have been designed for the following loads in accordance with AS/NZS1170 based on a Class 10a, Type 2 structure:
- Roof Live Load: 0.25 kPa uniformly distributed or 1.1 kN concentrated as per AS/NZS1170.1 and is only valid when the doors of the shed are shut.
- Wind Load: Classification N2, Non-Cyclonic to AS4055 where $V_u = 40$ m/s, $V_s = 26$ m/s

Windward wall $C_{p,e} = 0.7$

Leeward Wall $C_{p,e} = -0.3$ to -0.5 as applicable based on shed geometry

Side Wall $C_{p,e} = -0.5$ to -0.65 as applicable based on shed geometry

Roof $C_{p,e} = -0.5$ to -1.3 depending on wind direction

Absco Skillion Roof Shed Notes

Steelwork

- 1.S All structural steelwork shall have a corrosion protection system applied consistent with AS/NZS 2312-2014.
- 2.S All structural steelwork detailed within this installation manual shall be minimum Grade 550 for roll formed sections (including roof and wall sheeting) and Grade 250 for angle sections.
- 3.S All roof, and wall sheeting shall be minimum base metal thickness of 0.3mm
- 4.S All snaptite channels and jambs shall be minimum base metal thickness of 0.42mm
- 5.S All top hats shall be minimum base metal thickness of 1.0mm
- 6.S All screw fasteners shall be Phil Pan Head Zinc Plated #8 x 3/4" (STP0820)
- 7.S All bolt fasteners for anchoring shall be M10 minimum grade 4.6/S
- 8.S Installation of screw fasteners shall generally be undertaken in accordance with the relevant provisions of AS1562.

Supporting Slab and Foundations

- 1.F The supporting slab foundation for the garden shed shall be of a minimum size indicated on the installation manual. The top surface of the formed slab shall be level and free of any irregularities which would inhibit the installation of the shed.
- 2.F The structural engineering design for the supporting slab foundation shall be undertaken by a suitably qualified structural engineer. The design shall consider all relevant provision of AS3600 and AS2870.
- 3.F Between adjacent footings or excavations, the contractor installing the slab foundation shall not exceed a rise of 1 in a run of 2 in line of slope.
- 4.F Unless approved in writing by the slab foundation engineer, the limits of excavations near existing footings shall be in accordance with that indicated below.

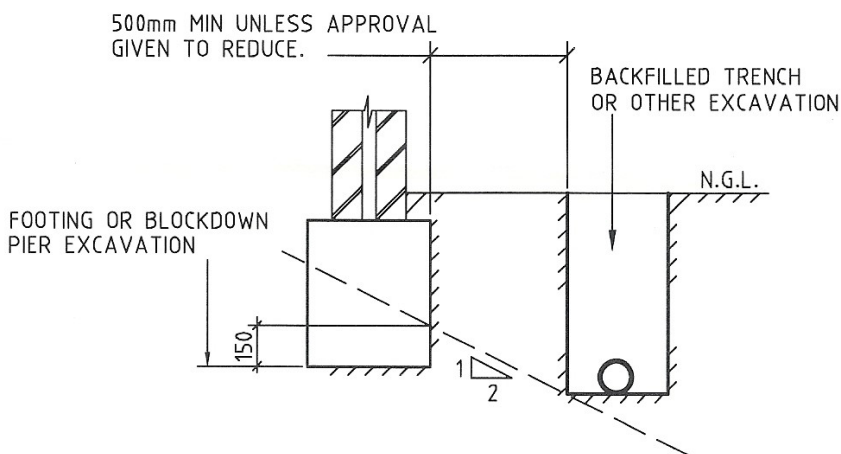

The contractor shall undertake investigatory localised excavations near existing footings to ascertain their depth prior to excavating adjacent to them. It is noted that excavating to a depth below that indicated above shall not be undertaken without the written approval from the engineer.

Absco Sheds Storage Guidelines

- Absco Sheds are designed to be weatherproof for normal weather conditions. In the event of extreme weather conditions such as heavy rain, combined with high wind gusts, the ridge capping, sheeting joints, screw fixings etc., may exhibit minor deformations which may allow some water entry. These areas should be checked regularly to ensure that maximum strength and protection is maintained.
- Other weather conditions such as extreme heat and extreme cold, moist or dry air can influence the effects of concrete floor moisture and/or condensation on the underside of the roof sheets.
- Absco Sheds and storage units are primarily used for storage of garden equipment such as lawnmowers, wheelbarrows, garden tools etc. Storage items that might be adversely affected by any of the above conditions may require additional protection such as being sealed or covered by plastic sheets and/or stacked above the concrete floor on timber slats.
- Waterproof sealants may be used to offer further protection where required around joins and screw fixings, as can rubber door seals and other products which are available from most hardware outlets.
- Placement of waterproof sealants (silicone) between the base of the shed and concrete slab is not recommended, as this process can have a reverse effect, preventing excess water from escaping, resulting with water accumulating and being trapped inside the shed.
- Absco accepts no responsibility for water entry, floor moisture, condensation or the condition of the Contents inside your Absco steel building arising from any of the pre-mentioned weather conditions.
- Absco accepts no responsibility for structural damage if doors were left open and/or not secured during a weather event.

Post-Installation Care

Clear final product of steel fillings (swarf) caused by drilling holes and tek screws.

Failure to do so may cause discolouration of surfaces and promote corrosion.

Refer to warranty for more details

Lifetime Warranty Statement



1. DEFINITIONS

In this document, capitalised terms have the following meaning:

- (a) "ABSCO" means John Scholtes Investments (No. 1) Pty Ltd trading as Absco Industries.
- (b) "Authorised Purpose" means for storage (other than storage of corrosive materials), and other activities typically expected of a non-habitable structure.
- (c) "Defect" means a defect in the design, workmanship, materials, or any other defect caused by the manufacturing process of the Product (including damaged or missing parts).
- (d) "Excluded Environment" means land located within 1km of:
 - (i) salt marine locations or other areas of marine influence;
 - (ii) severe industrial or other abnormally or highly corrosive environments;
 - (iii) areas not washed by rain;
 - (iv) a recognised flood, bushfire or earthquake zone; or
 - (v) areas with uncontrolled fill, unless an engineered foundation is constructed.
- (e) "Lifetime Warranty Period" means the period of 35 years, commencing on the day after the date of purchase of the Product.
- (f) "Lifetime Warranty Statement" means this 'Lifetime Warranty Statement' document.
- (g) "Parties" means ABSCO and You.
- (h) "Product" means any of following unless stated otherwise in the product description and/or the Product Guide for the Product:
 - (i) products which utilise ABSCO 'SNAP-TITE' technology, including but not limited to garden sheds, chicken coops, bike sheds and bin covers; and
 - (ii) all non-insulated large structures such as carports, awnings, shades and garages,but does not include any product stated to be in the "ABSCO Economy" range.
- (i) "Product Guide" means the guide for installation and maintenance of the Product produced by ABSCO.
- (j) "You" / "Your" means the customer who purchased or installed the Product, or the person who owns the land upon which the Product is installed but does not include a subsequent purchaser of the Product where the Product is moved to a different location to that originally installed.

2. ABSCO'S STRUCTURAL WARRANTY

- 2.1. ABSCO provides this warranty to You in relation to the Product. The warranty applies to all colours and finish variants of the Product manufactured by ABSCO and sold by authorised sellers of the Product in Australia or New Zealand.
- 2.2. Subject to the terms of this Lifetime Warranty Statement:
 - (a) ABSCO warrants that the Product will be free from Defects for the duration of the Lifetime Warranty Period; and
 - (b) where the Product contains a Defect, ABSCO will either repair or replace the Product, or provide You with monetary compensation for the Defect in accordance with clause 3.

3. WARRANTY CLAIM PROCEDURE

- 3.1. If, during the Lifetime Warranty Period, You believe the Product has a Defect, You must comply with the procedure set out in this clause 3.
- 3.2. Within 30 days of becoming aware of the Defect in the Product, You must notify ABSCO in writing of the alleged Defect ("Defect Notice") by email to admin@absco.com.au.
- 3.3. The Defect Notice must include:
 - (a) Your name, address and contact details;
 - (b) proof of purchase of the Product, including the colour and finish of the Product;
 - (c) the date and location of the installation of the Product and details of the contractor or installer of the Product;
 - (d) details of the alleged Defect in the Product, including but not limited to:
 - (i) a clear description of the alleged Defect;
 - (ii) the date the alleged Defect was first identified; and
 - (iii) any photographs and/or video footage of the alleged Defect.
- 3.4. As soon as reasonably practicable after receipt of the Defect Notice, ABSCO will contact You to investigate the alleged Defect. You must make the Product available to ABSCO and/or its authorised representatives for inspection and testing if so required.
- 3.5. A travel fee may apply if ABSCO and/or its authorised representatives are required to inspect the Product outside a capital metropolitan city area.
- 3.6. If ABSCO's investigations reveal a genuine Defect in the Product, ABSCO may elect to either:
 - (a) repair the Product;
 - (b) replace all or part of the Product; or
 - (c) refund all or part of the purchase price paid by You as compensation for the Defect in the Product.
- 3.7. ABSCO's election in clause 3.6 is at ABSCO's sole discretion.
- 3.8. If ABSCO elects to repair the Product, ABSCO will arrange for a qualified tradesperson to attend to the rectification of the Defect as soon as reasonably practicable. The cost of the repair will be borne by ABSCO.
- 3.9. If ABSCO elects to replace the Product:
 - (a) ABSCO will arrange for the replacement Product to be available for collection by You from the nearest ABSCO authorised reseller as soon as reasonably practicable;
 - (b) You may be required to return the alleged Defective parts or components to ABSCO; and
 - (c) You will be liable for the cost of disassembly and removal of the Product and assembly of the replacement Product.
- 3.10. If ABSCO elects to repair or replace the Product and the necessary parts or components are no longer manufactured or supplied by ABSCO, ABSCO may repair or replace the parts or components with parts or components of a similar quality, grade, composition and colour. You cannot object to such an alternative.
- 3.11. If ABSCO's investigations do not reveal a genuine Defect in the Product (including a defect which is not covered by this warranty), You agree to pay ABSCO's reasonable investigation costs.

4. WARRANTY LIMITATIONS / EXCLUSIONS

4.1. To the extent permitted by law, this warranty will not apply where:

- (a) the Product has been installed or used for a purpose that is not an Authorised Purpose;
- (b) the Product has not been installed, assembled, maintained and/or operated in complete compliance with ABSCO's Product Guide;
- (c) the Product has been used to store corrosive materials such as fertiliser or chlorine;
- (d) the Product was installed in excess of 12 months after the purchase of the Product;
- (e) the Product has not been installed in accordance with the relevant standards, codes and statutory regulations;
- (f) the Defect is determined to have been caused by storm, wind, rain, earthquake, fire, snow or poor foundations;
- (g) the Defect is, or is the result of, surface deterioration of panels caused by 'swarf' (tiny particles of steel debris left from cutting, grinding or drilling operations);
- (h) the Product has been installed in an Excluded Environment;
- (i) the Product has been subject to accident, negligence, alteration, abuse or misuse;
- (j) the Defect is determined to be the result of overloading; or
- (k) ABSCO determines that the Defect is the result of a failure of a third-party product.

4.2. You acknowledge that:

- (a) dimensions and colour of the Product are subject to normal manufacturing variations and tolerances, and that reasonable variances are not considered a Defect under this warranty; and
- (b) this warranty is limited to the repair or replacement of Defects in the Product and does not extend to any other product or any other consequential or indirect damage incurred as a result of the Defect.

4.3. For the purpose of this warranty, the following matters are excluded from the definition of Defect:

- (a) general wear and tear which is reasonably expected to occur over the life of the Product;
- (b) surface deterioration of panels caused by 'swarf' (tiny particles of steel debris left from cutting, grinding or drilling operations);
- (c) condensation caused by weather conditions such as extreme heat or cold;
- (d) defects in any fastening apparatus (screws, nuts, bolts, rivets, hasps or bolts);
- (e) leaks caused by driving rain;
- (f) improper installation, maintenance or handling of the Product;
- (g) movement, distortion, collapse or settling of the ground or the supporting structure on which the Product is installed; or
- (h) staining from foreign substances (including mould, mildew, dirt, grease, oil and any other substance).

4.4. To the extent permitted by law, ABSCO is not liable to compensate You for any:

- (a) increased costs or expenses;
- (b) loss of profit, revenue, business, contracts or anticipated savings;
- (c) loss or expense resulting from a claim by a third-party; or

- (d) special, indirect or consequential loss or damage of any nature whatsoever, arising from a Defect in the Product or ABSCO's repair or replacement of the Product under this warranty.

5. CONSUMER LAW

Australian Consumer Law

5.1. Clauses 5.2 to 5.3 apply where the Product was purchased in Australia.

5.2. The Product comes with guarantees that cannot be excluded under the Australian Consumer Law. You may be entitled to a replacement or refund for a major failure of the Product and compensation for any other reasonably foreseeable loss or damage. You may also be entitled to have the Product repaired or replaced if the Product fails to be of acceptable quality and the failure does not amount to a major failure.

5.3. The benefits of this Lifetime Warranty Statement are in addition to any rights and remedies imposed by Australian State and Federal legislation that cannot be excluded. Nothing in this Lifetime Warranty Statement is to be interpreted as excluding, restricting or modifying any State or Federal legislation applicable to the supply of goods and services which cannot be excluded, restricted or modified.

New Zealand Consumer Law

5.4. Clauses 5.5 to 5.6 apply where the Product was purchased in New Zealand.

5.5. This warranty is subject to the laws of New Zealand, including but not limited to the New Zealand Sale of Goods Act, the Consumer Guarantees Act and the Fair Trading Act.

5.6. The benefits of this Lifetime Warranty Statement are in addition to any rights and remedies imposed by New Zealand legislation that cannot be excluded. Nothing in this Lifetime Warranty Statement is to be interpreted as excluding, restricting or modifying any New Zealand legislation applicable to the supply of goods and services which cannot be excluded, restricted or modified.

6. NO REPRESENTATIONS / ENTIRE AGREEMENT

6.1. You agree and acknowledge that this Lifetime Warranty Statement contains the entire agreement between the Parties regarding the warranty provided by ABSCO to You in relation to the Product.

6.2. To the full extent permitted by law, this Lifetime Warranty Statement supersedes all other warranties of any kind, including whether express or implied by representations, statement, correspondence or other conditions such as merchantability or fitness for purpose.

7. REGISTRATION OF WARRANTY

7.1. Please ensure that You keep this Lifetime Warranty Statement in a safe place along with your proof of purchase of the Product.

7.2. To ensure ABSCO has a record of your warranty, You can register Your warranty online at <http://absco sheds.com.au/warranty-details/>.