



# MIMOSA®

THE SIGNATURE COLLECTION

## ASSEMBLY INSTRUCTIONS



### CROMWELL 4PCE KWILA GARDEN LOUNGE SETTING

FSC® 100% Kwila Hardwood

- Pre-Bled to Minimise Tannin Leaching
- Table - 120L x 60W x 45H CM
- Bench - 149.6L x 65.5W x 91.4H CM  
Max. Weight Capacity: 330kg (110kg per Seat)
- Chair - 56L x 65.5W x 91.4H CM  
Max. Weight Capacity: 110kg per Seat



# SECTION 1 - CHAIR

## PARTS LIST

**CAUTION!**  
This product weighs 22.4kg.  
Assembly requires 2 people to  
avoid injury.

### Timber Components

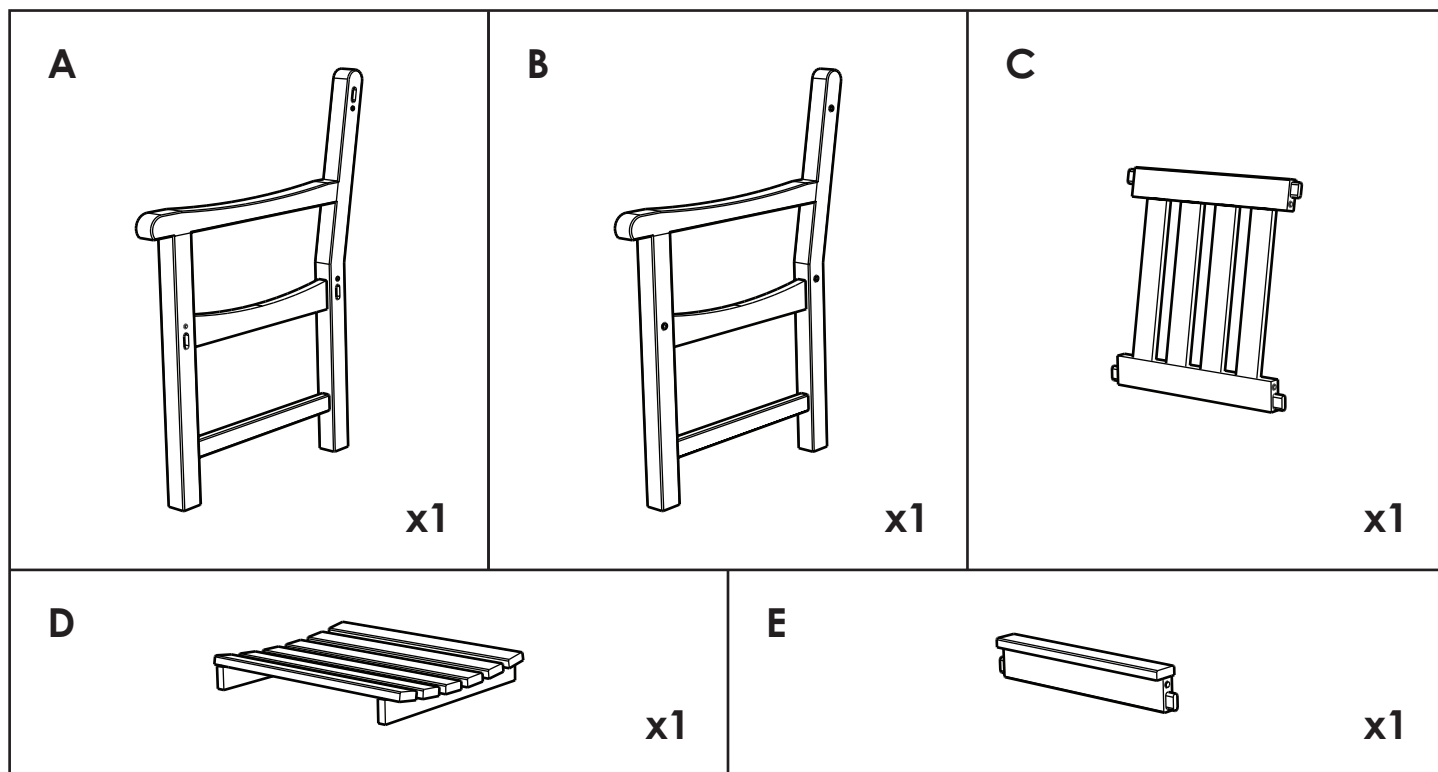

### Hardware

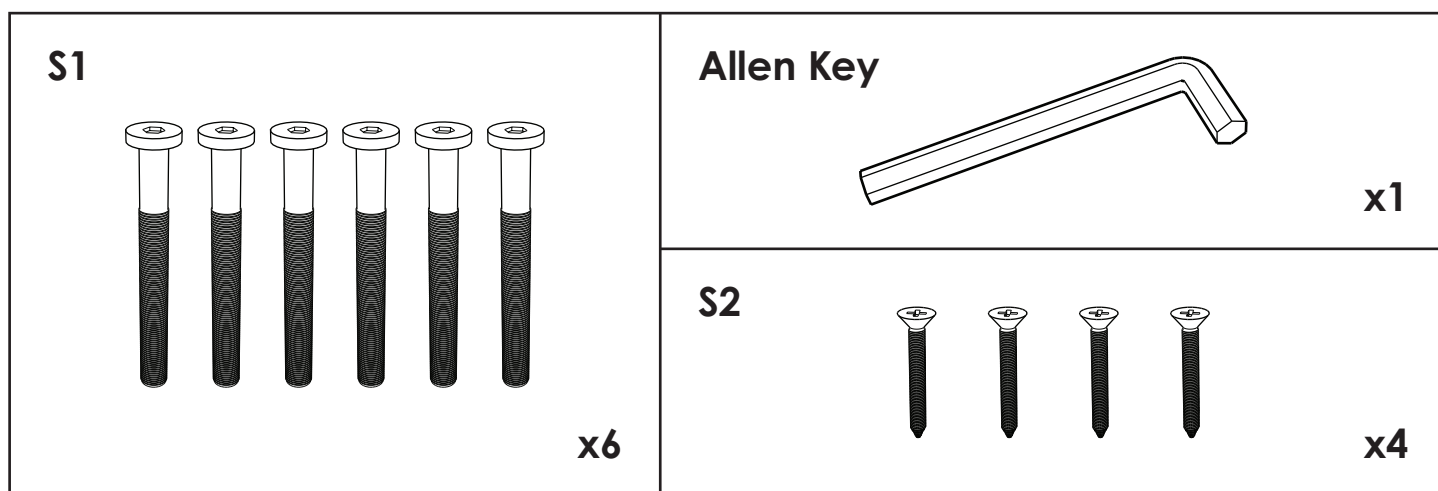

### Not Supplied

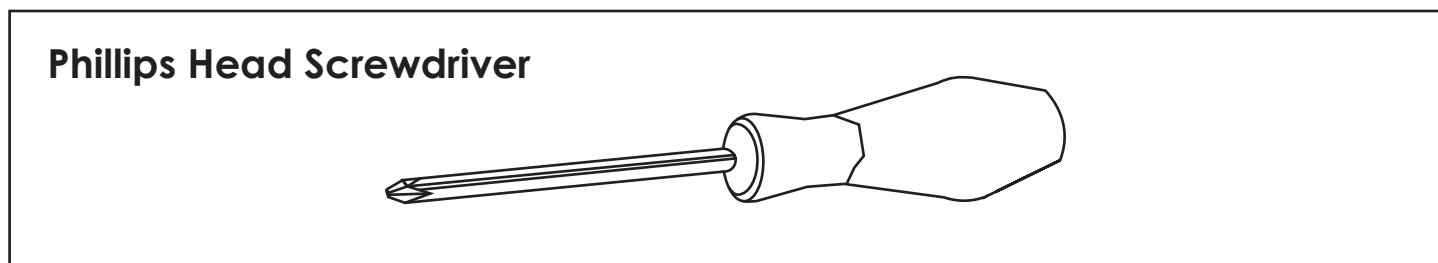

# SECTION 1 - CHAIR

## ASSEMBLY INSTRUCTIONS

### Step 1

Place **Component A** flat on the ground and insert **Component C** and **Component E** into the relevant slots.

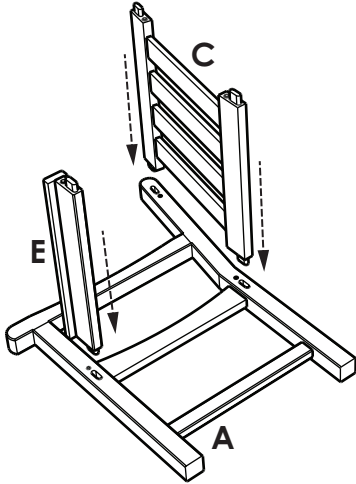

### Step 2

Place **Component D** into the gap between **Component C** and **Component E**.

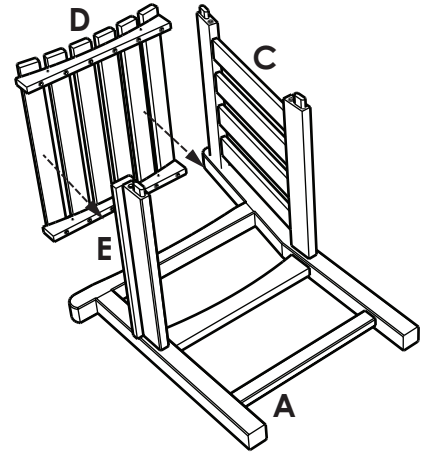

### Step 3

Slot **Component B** onto the relevant inserts of **Component C** and **Component E**.

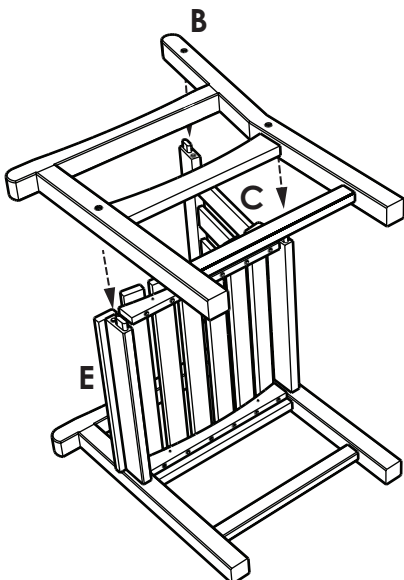

### Step 4

Once all the components are slotted together, affix **Component B** to **Component C** and **Component E** using 3 x **S1 Screws** and the **Allen Key** provided.

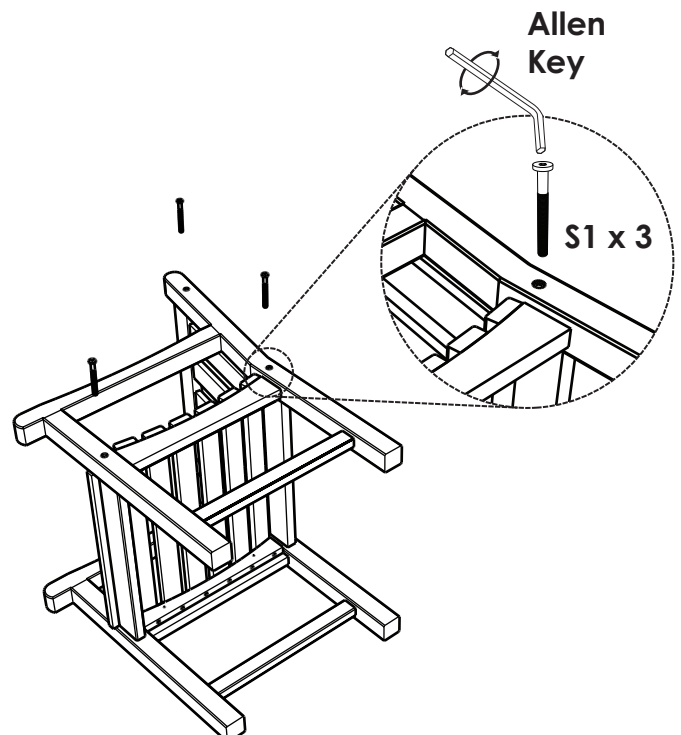

# SECTION 1 - CHAIR

## ASSEMBLY INSTRUCTIONS

### Step 5

Carefully rotate the chair keeping all components together and repeat **Step 4** on the other side.

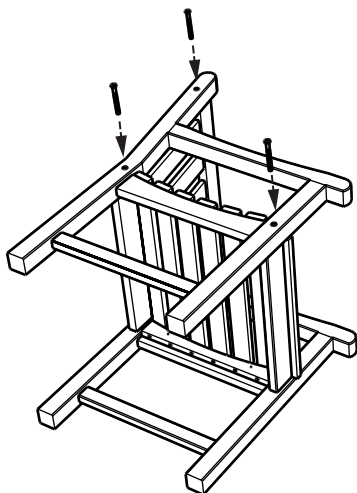

### Step 6

Make sure **Component D** is still in place correctly. Holding **Component D** firmly in place, affix it to the chair frame using the **4 x S2 Screws** and a **Phillips Head Screwdriver**.

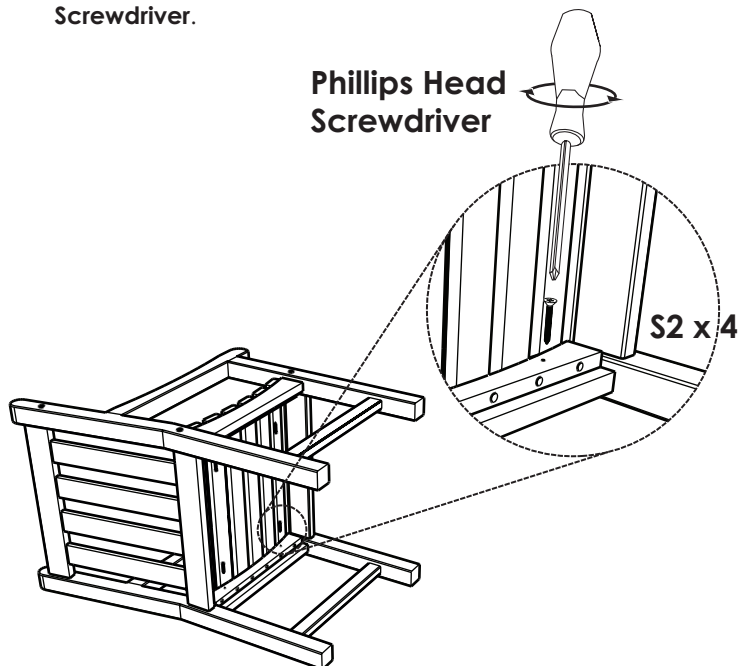

### Step 7

Rotate the chair to its upright position and **tighten all screws**.

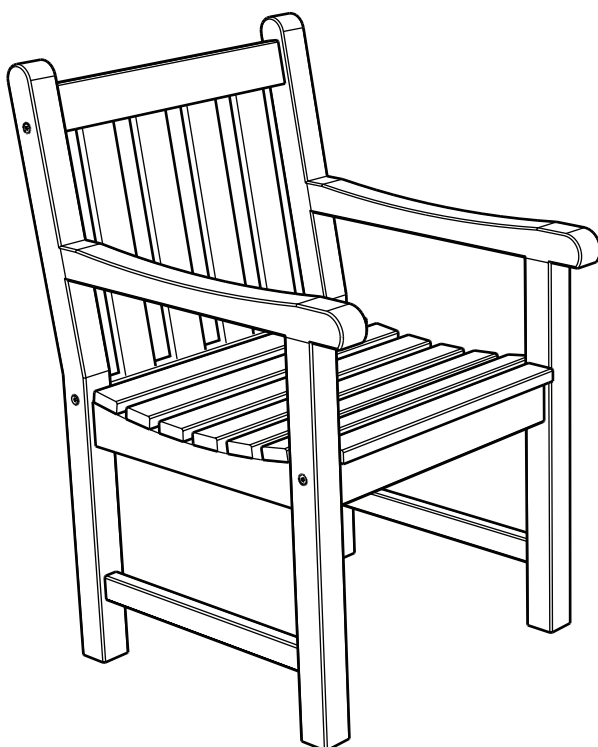

#### IMPORTANT SAFETY INFORMATION

Furniture should not be dragged at any time.

As an added precaution we strongly recommend you choose to tighten any loose fittings and joints after an initial period of use of around 3-6 months. For assured long life of your furniture, regular checking and tightening of any screws and bolts should be carried out on a 6-12 monthly basis.

# SECTION 2 - BENCH



## PARTS LIST

**CAUTION!**  
This product weighs 35.4kg.  
Assembly requires 2-3 people to  
avoid injury.

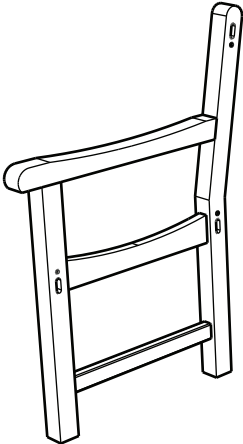
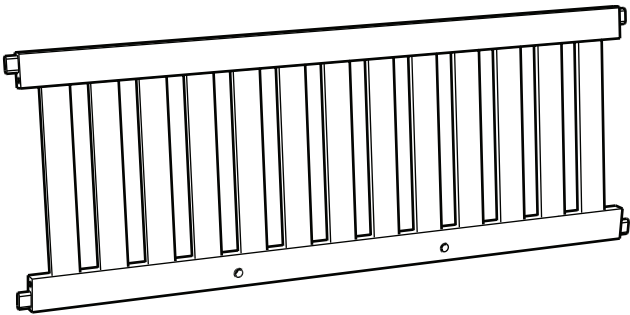
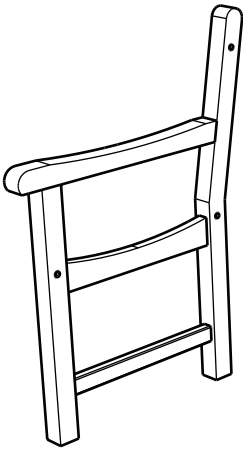
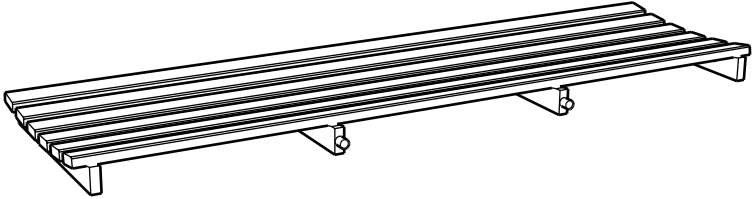
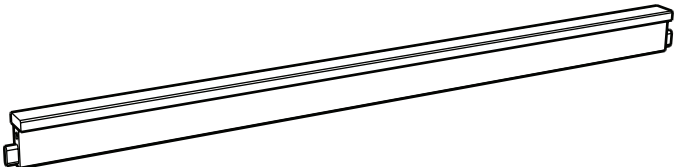
### Timber Components

<b>A</b>  x1	<b>C</b>  x1
<b>B</b>  x1	<b>D</b>  x1
	<b>E</b>  x1

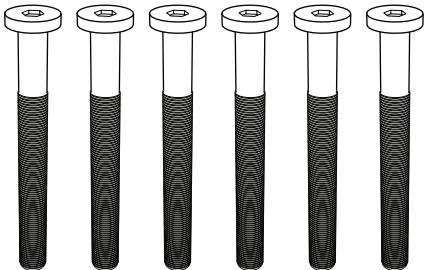
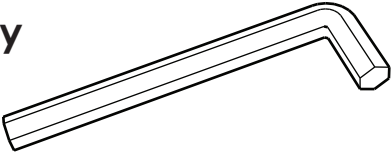
### Hardware

<b>S1</b>  x6	<b>Allen Key</b>  x1
	<b>S2</b>  x4

### Not Supplied

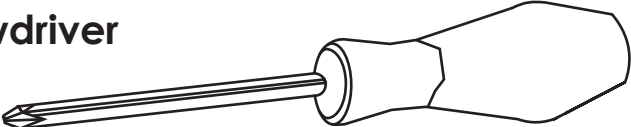
<b>Phillips Head Screwdriver</b> 
--

# SECTION 2 - BENCH

## ASSEMBLY INSTRUCTIONS

### Step 1

Place **Component A** flat on the ground and insert **Component C** into the relevant slots.

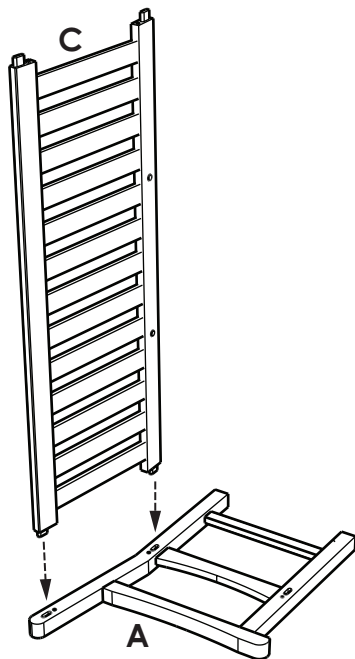

### Step 2

Insert **Component D** into relevant slots on **Component C** and **Component E**.

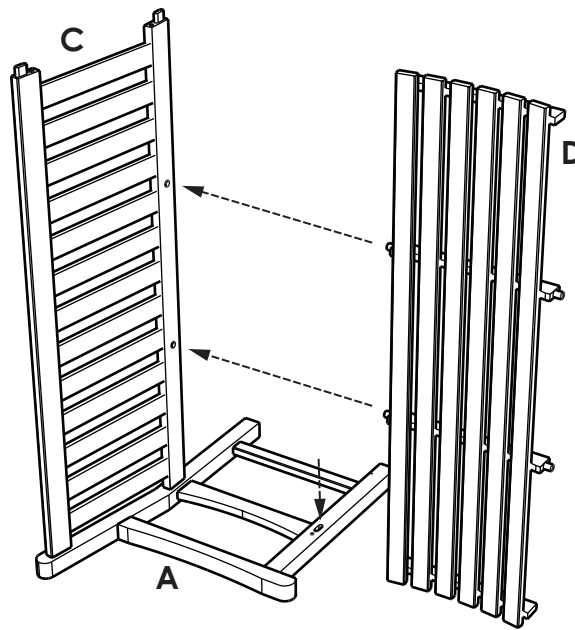

### Step 3

Insert **Component E** into the relevant slots of **Component A** and **Component D**.

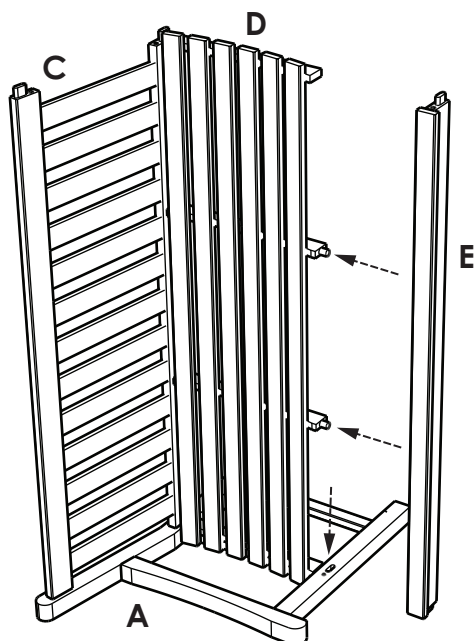

### Step 4

Slot **Component B** onto the relevant inserts of **Component C** and **Component E**.

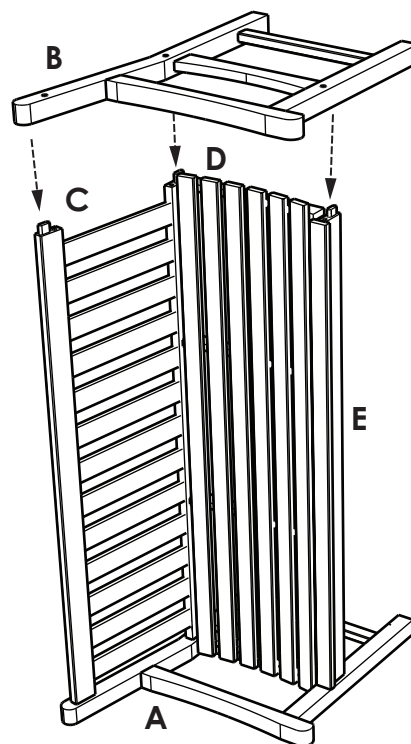



# SECTION 2 - BENCH

## ASSEMBLY INSTRUCTIONS

### Step 5

Once all the components are slotted together, affix **Component B** to **Component C** and **Component E** using **3 x S1 Screws** and the **Allen Key** provided.

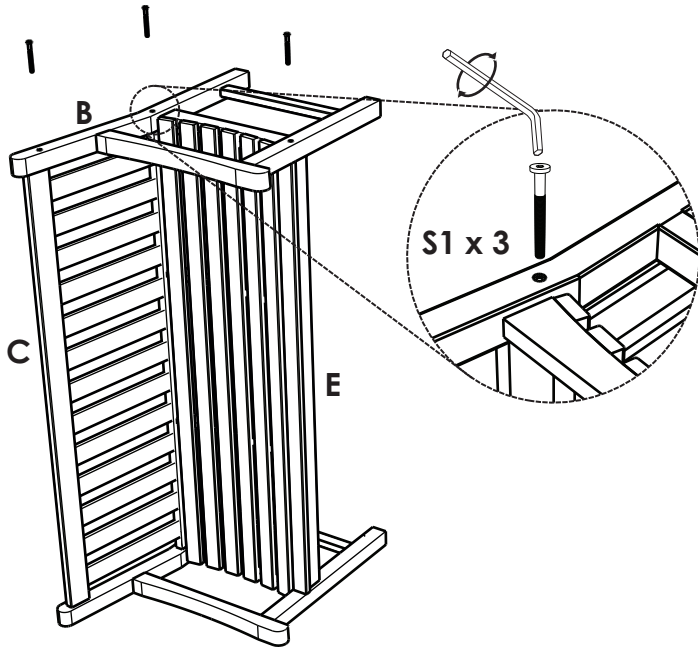

### Step 6

Carefully rotate the bench keeping all components together and repeat **Step 5** on the other side.

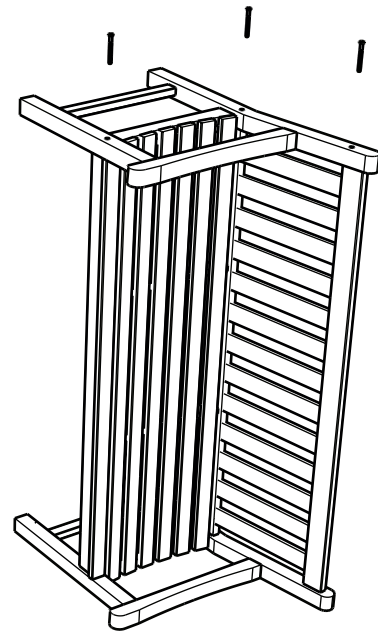

### Step 7

Make sure **Component D** is still slotted into place correctly. Holding **Component D** firmly in place, affix it to the bench frame with using the **4 x S2 Screws** and a **Phillips Head Screwdriver**.

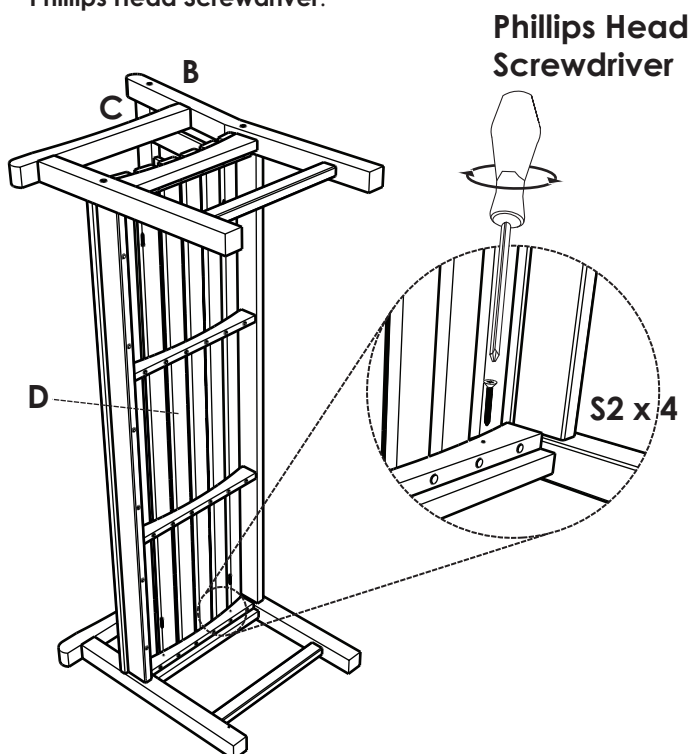

### Step 8

Rotate the bench to its upright position and **tighten all screws**.

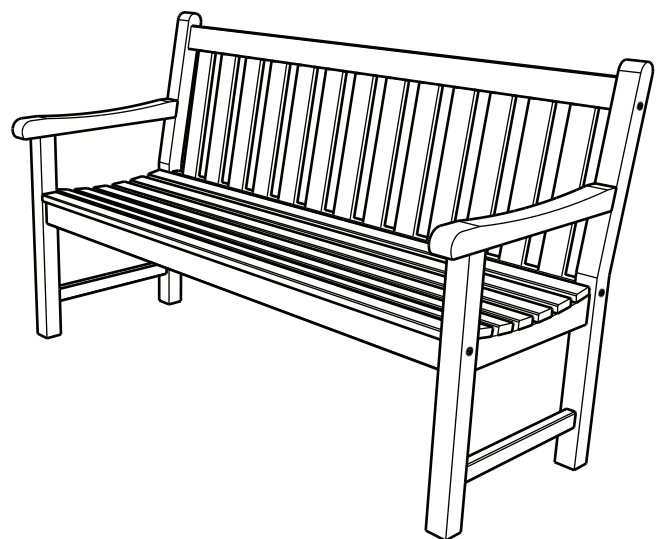

#### IMPORTANT SAFETY INFORMATION

Furniture should not be dragged at any time. As an added precaution we strongly recommend you choose to tighten any loose fittings and joints after an initial period of use of around 3-6 months. For assured long life of your furniture, regular checking and tightening of any screws and bolts should be carried out on a 6-12 monthly basis.

# SECTION 3 - TABLE

## PARTS LIST

**CAUTION!**  
This product weighs 21.6kg.  
Assembly requires 2 people to  
avoid injury.

### Timber Components

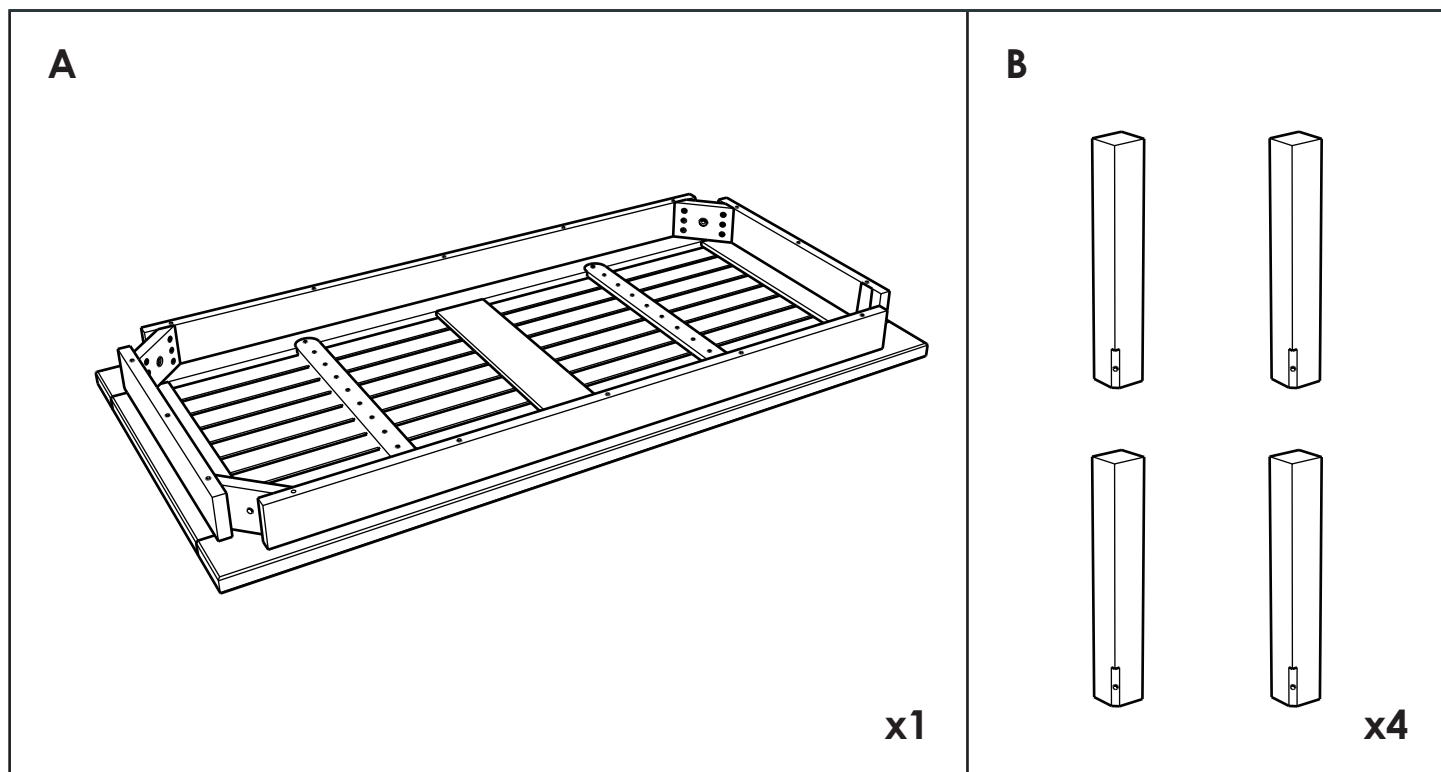

### Hardware

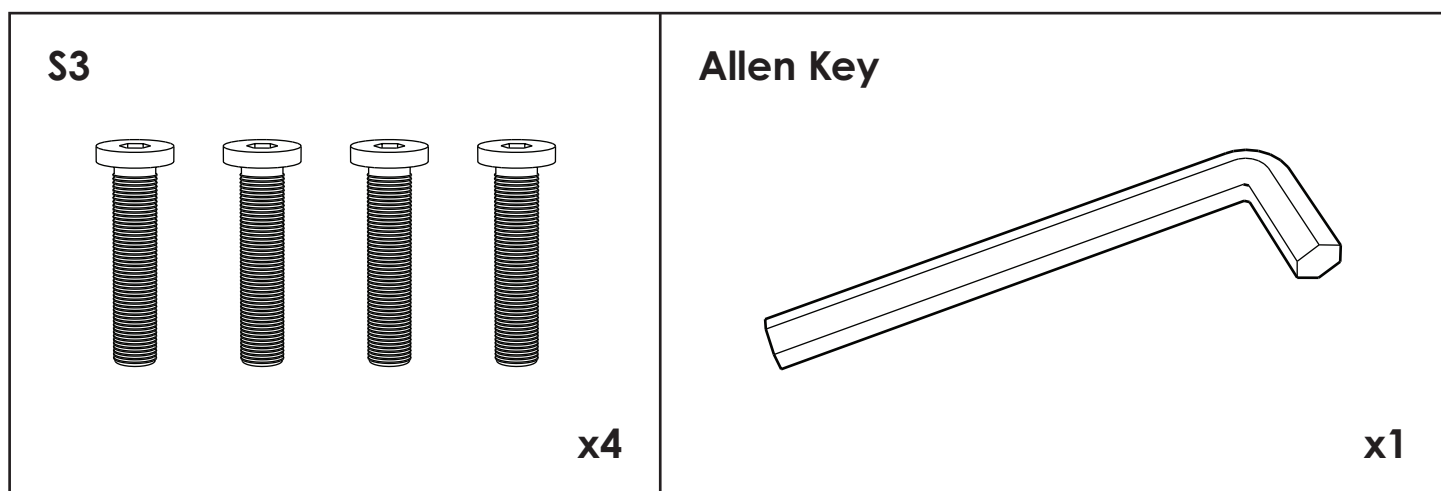



# SECTION 3 - TABLE

## ASSEMBLY INSTRUCTIONS

### Step 1

Place **Component A** upside down on the ground and place the table legs (**Component B**) into position.

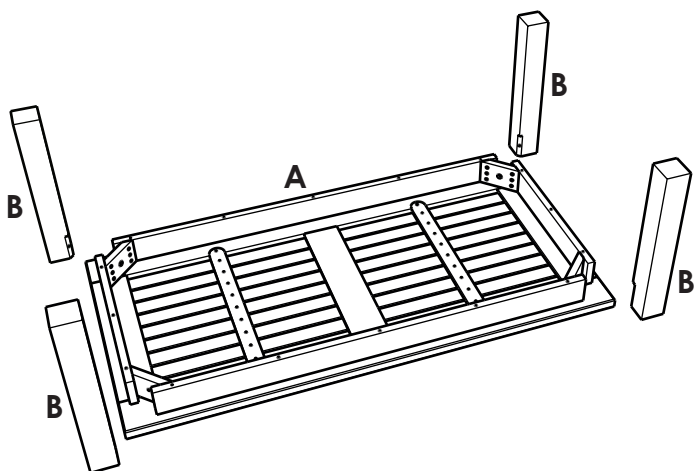

### Step 2

Holding the table legs (**Component B**) firmly in place, affix them to the table top using **4 x S3 Screws** and the **Allen Key** provided.

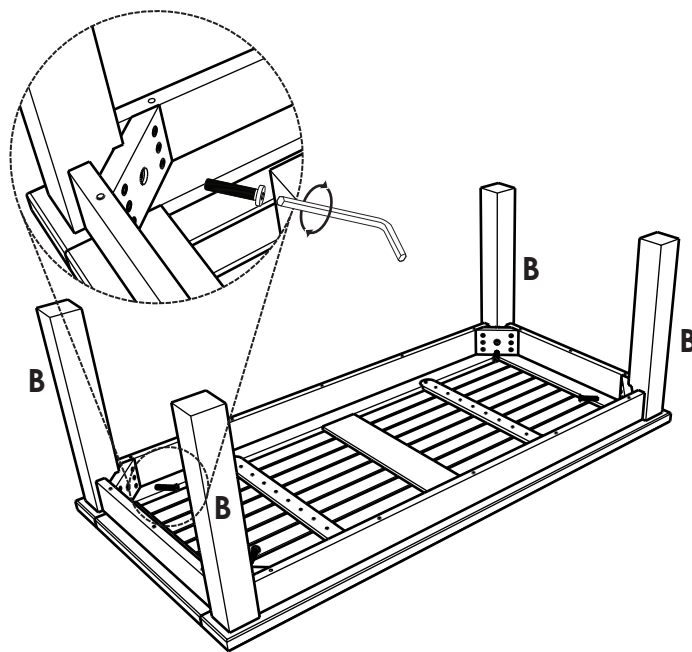

### Step 3

**Tighten all screws** and rotate the table to its upright position.

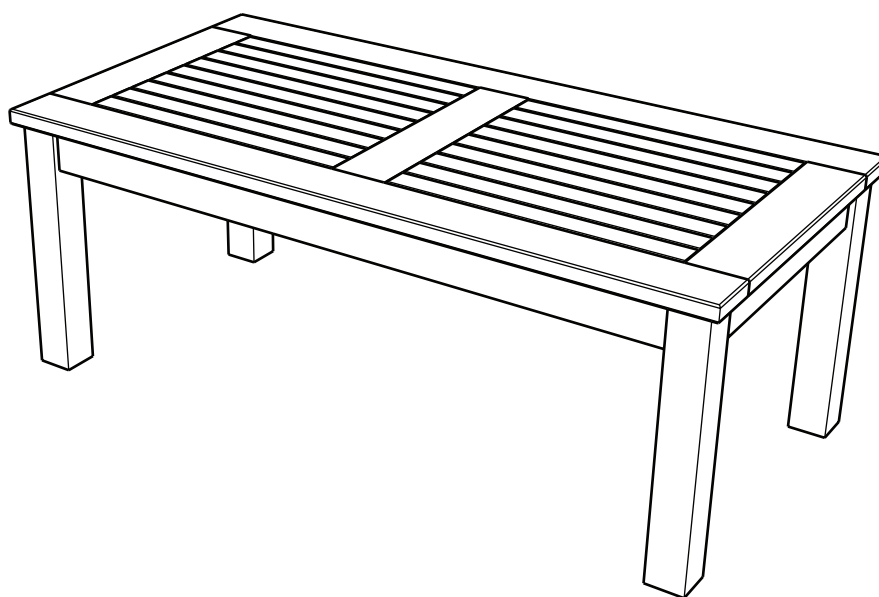

#### IMPORTANT SAFETY INFORMATION

Furniture should not be dragged at any time.

As an added precaution we strongly recommend you choose to tighten any loose fittings and joints after an initial period of use of around 3-6 months. For assured long life of your furniture, regular checking and tightening of any screws and bolts should be carried out on a 6-12 monthly basis.