



MATADOR™



WOOD FIRED PIZZA OVEN
MODEL: HS-18JP8000

Retain manual for future reference.



TABLE OF CONTENTS

IMPORTANT SAFETY WARNINGS	2
GENERAL INFORMATION	3
EXPLODED PARTS VIEW	4
PARTS LIST	5
HARDWARE PACK	7
ASSEMBLY STEPS	8
HOW TO USE THE PIZZA OVEN	17
WARRANTY	19



IMPORTANT SAFETY WARNINGS

FOR OUTDOOR USE ONLY

1. DO NOT OPERATE THIS APPLIANCE BEFORE READING THE INSTRUCTION BOOKLET.
2. DO NOT PLACE ARTICLES ON OR AGAINST THIS APPLIANCE.
3. DO NOT STORE CHEMICALS OR FLAMMABLE MATERIALS OR SPRAY AEROSOLS NEAR THIS APPLIANCE.
4. DO NOT OPERATE THIS APPLIANCE INDOORS.
5. DO NOT ENCLOSE THIS APPLIANCE.
6. DO NOT LIGHT OR OPERATE WITH A COVER ON.
7. Servicing can only be carried out by authorised technicians.
8. Do not store chemicals or flammable materials near this appliance.
9. Children must be supervised at all times while they are in the vicinity of this Pizza Oven.
10. This Pizza Oven should not be located under overhead combustible construction.
11. Remove stickers (where fitted) before use.
12. Do not store LPG cylinders in the vicinity of this Pizza Oven.
13. The use of this appliance in enclosed areas is extremely dangerous and is prohibited.
14. Never move oven when it is in use or when it contains hot coals or ashes.
15. Do not use accelerants. This could lead to an explosion and bodily injury.
16. Never use treated timber in your oven.
17. The oven gets very hot during use. To protect yourself from burns, always wear shoes, oven mitts or gloves and protective clothing with long sleeves while operating this oven. Avoid touching hot surfaces and be very careful when opening the oven door.
18. Place Oven in an area where children and pets cannot come into contact with the unit. Do not leave Oven unattended when in use.
19. This appliance is not intended for use by persons (including children) with reduced physical, sensory or mental capabilities, or lack of experience and knowledge, unless they have been given supervision or instruction concerning use of the appliance by a person responsible for their safety.

The user assumes all risk in the assembly and operation of this oven. Failure to follow the warnings and instructions in this manual can result in severe personal injury, death or property damage. If the user cannot read or fully understand the instruction manual, please contact your supplier for assistance.

GENERAL INFORMATION

Improper installation, adjustment, alteration, service or maintenance can cause property damage, injury or death. Read the installation, operating and maintenance instructions thoroughly before installing or servicing this equipment

Strong winds can affect the heating and performance of your Oven so factor in these elements when positioning your Oven.

Never use your Oven in a garage, porch, shed, breezeway or any other enclosed area. Your Oven is to be used outdoors only,. Do not obstruct the flow of ventilation air around the Oven.





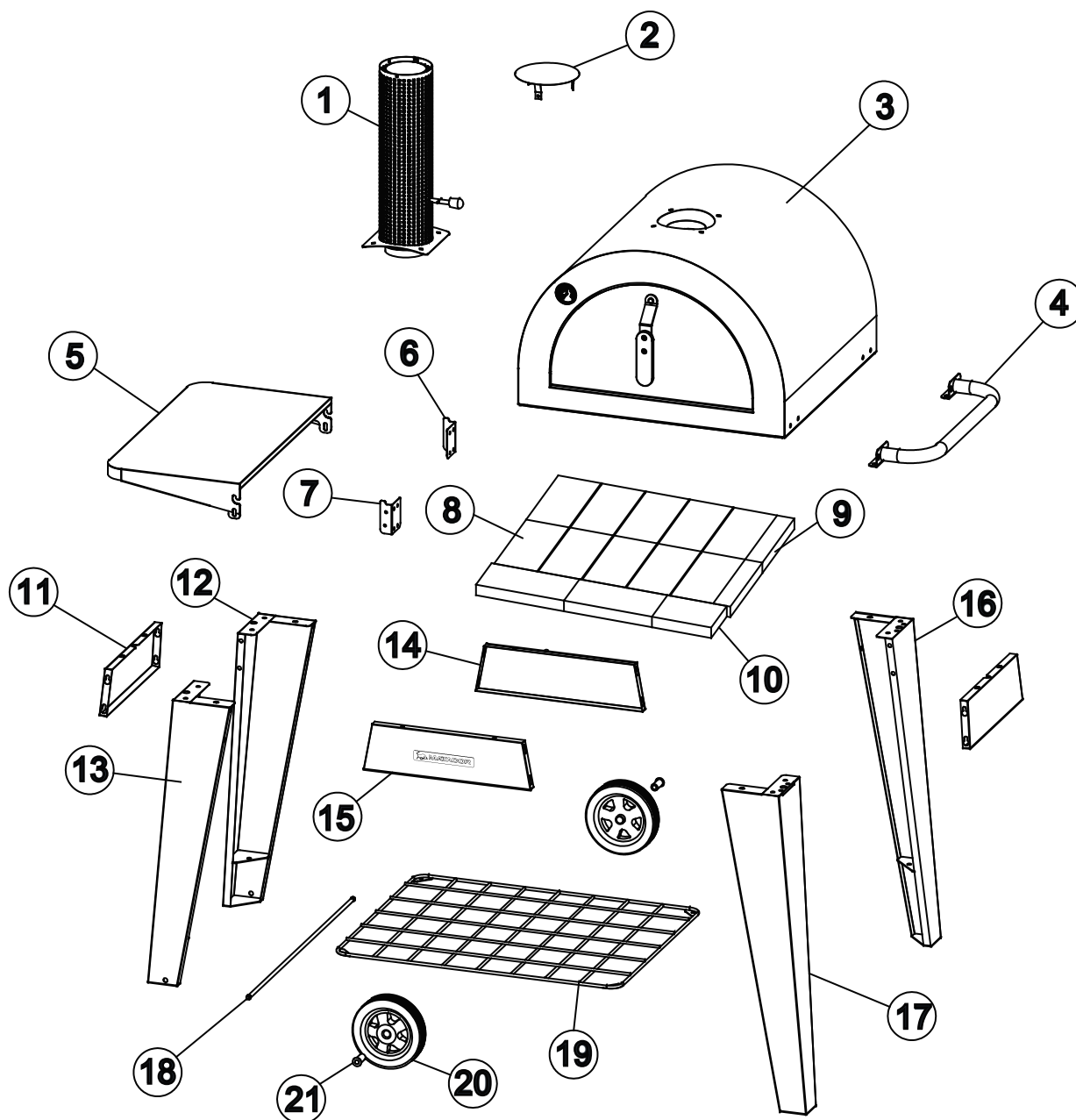

Any modification of the appliance may be dangerous.



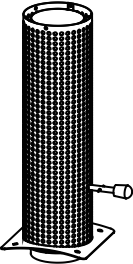
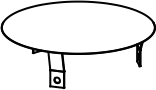
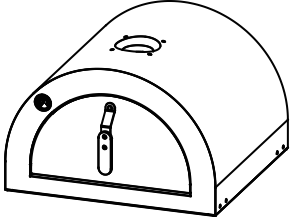
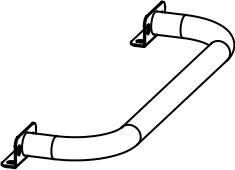
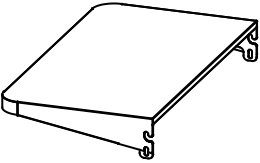
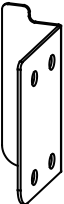
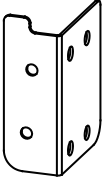
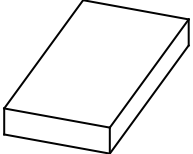
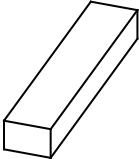

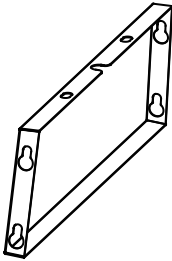

EXPLODED PARTS VIEW

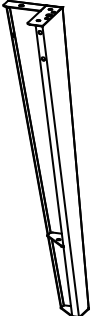





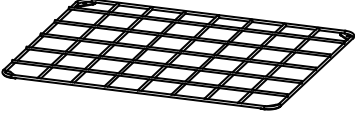

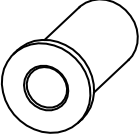
PARTS LIST

<p>1 Chimney</p> 	<p>2 Chimney cover</p> 	<p>3 Pizza oven</p> 	<p>4 Side handle</p> 
<p>5 Side table</p> 	<p>6 Back connection bracket for side table</p> 	<p>7 Front connection bracket for side table</p> 	<p>8 Brick X 12</p> 
<p>9 Brick B X 2</p> 	<p>10 Brick A</p> 	<p>11 Side crossbeam of cabinet X2</p> 	<p>12 Left back feet</p> 
<p>13 Left front feet</p> 	<p>14 Back crossbeam of cabinet</p> 	<p>15 Front crossbeam of cabinet</p> 	<p>16 Right back feet</p> 

PARTS LIST - CONTINUED

<p>17 Right front feet</p>  A perspective drawing of a long, narrow, tapered rectangular piece, likely a leg or foot for a chair or stool.	<p>18 Axle</p>  A simple line drawing of a long, thin cylindrical rod with slightly tapered ends.	<p>19 Bottom Shelf</p>  A perspective drawing of a rectangular metal mesh or grid, consisting of a series of intersecting lines forming a grid pattern.	<p>20 Wheels X 2</p>  A perspective drawing of a single wheel with a multi-spoke hub and a thick, black rubber tire.
<p>21 Spacer X2</p>  A perspective drawing of a short, hollow cylindrical tube with a circular opening at one end.			

HARDWARE PACK

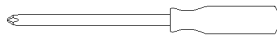
A	Screw: M6*12 	48	B	Nut: M12 	2
C	Screw: M6*16 	12	D	Screw: M4*8 	3
E	Nut: M6 	6	F	Washer: M12 	2
G	Step screw : M6*14 	2	H	Screwdriver 	1

ASSEMBLY STEPS

Remove all packaging and transit protection materials from parts before assembly.
Wear gloves when assembling your oven to avoid scrapes or cuts from sharp edges of metal parts.

STEP 1

Assemble the right back feet (16) and the right front feet (17) by screw (A) 6pcs as shown. Note: Ensure you protect oven when assembling surfaces. Do not fully tighten these screws at this step.

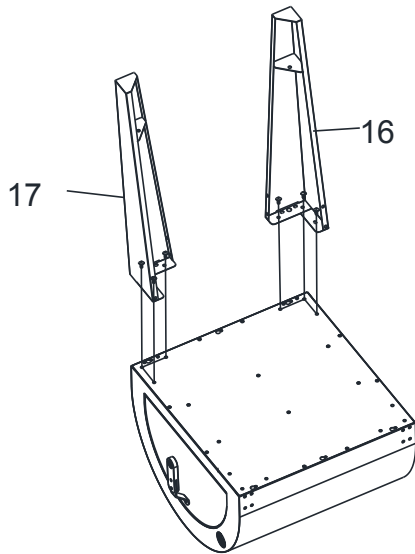

STEP 2

Assemble the left front feet (13) and the left back feet (12) by screw (A) 6pcs as shown. Note: Do not fully tighten these screws at this step.

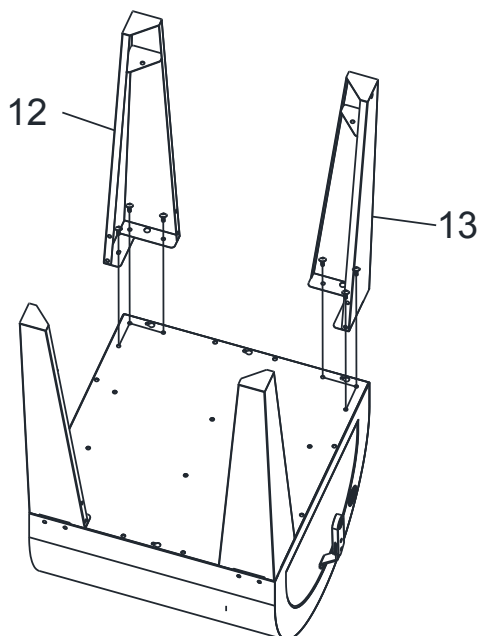

STEP 3

Assemble the side handle (4) on the pizza oven by screw (C) 8pcs as shown.

Note: Do not fully tighten these screws at this step.

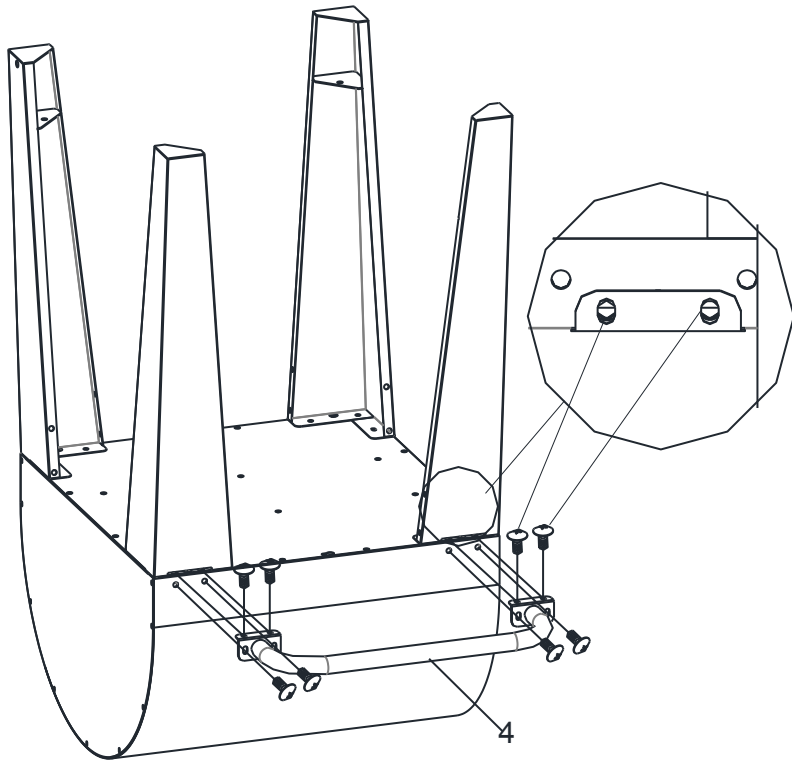

STEP 4

Assemble the side crossbeam of cabinet (11) on the feet (12),(13),(16),(17).by screw (A) 12pcs as shown.

Note: Do not fully tighten these screws at this step.

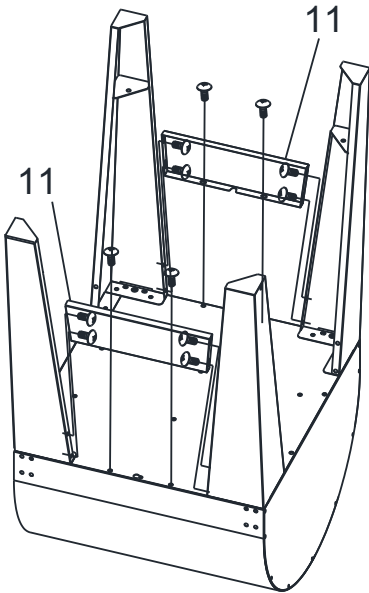

STEP 5

Assemble the front crossbeam of cabinet (15) and the back crossbeam of cabinet (14) on the feet (12),(13),(16),(17).by screw (A) 12pcs as shown.

Note: Do not fully tighten these screws at this step.

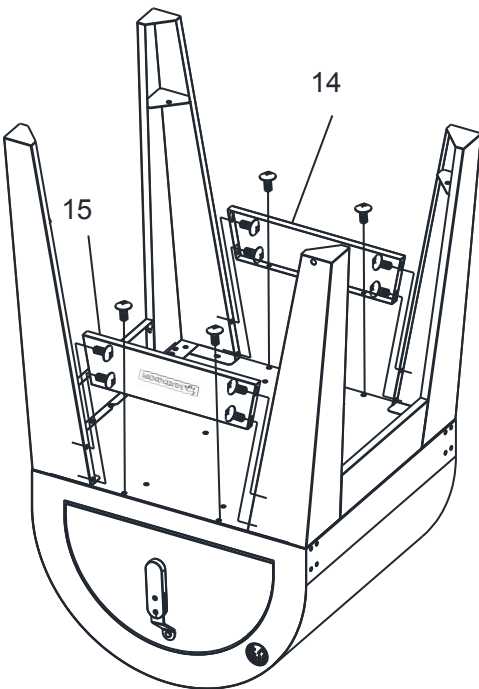

STEP 6

Assemble the bottom shelf (19) on the feet by screw (A) 4pcs and nut (E)4pcs as shown.

Note: Now all screws are in position you can tighten all the screws on the feet and crossbeam and side handle.

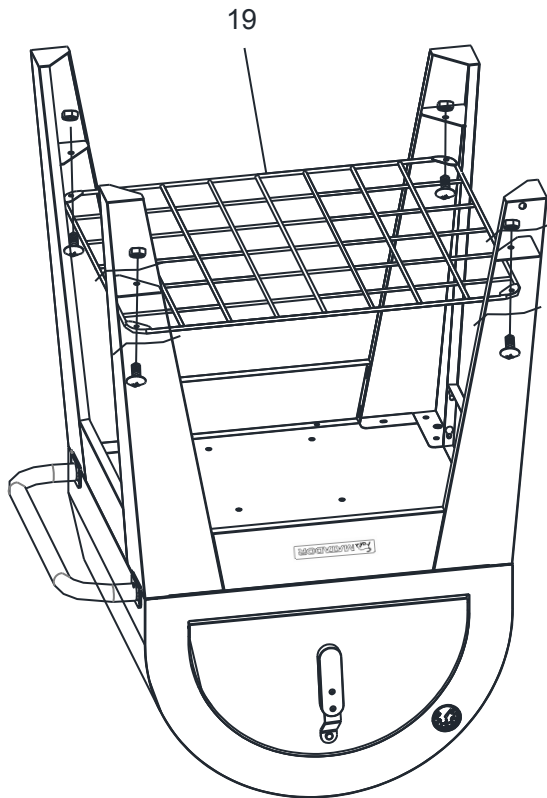

STEP 7

Assemble the axle(18)and wheels(20)and spacer (21) on the left front feet (13) and the left back feet (12) by nut (B) 2pcs and washer (F) 2pcs as shown.

Note: Secure the axle (18) when tightening nuts (B). After all screws are tightened, carefully turn the oven onto its feet.

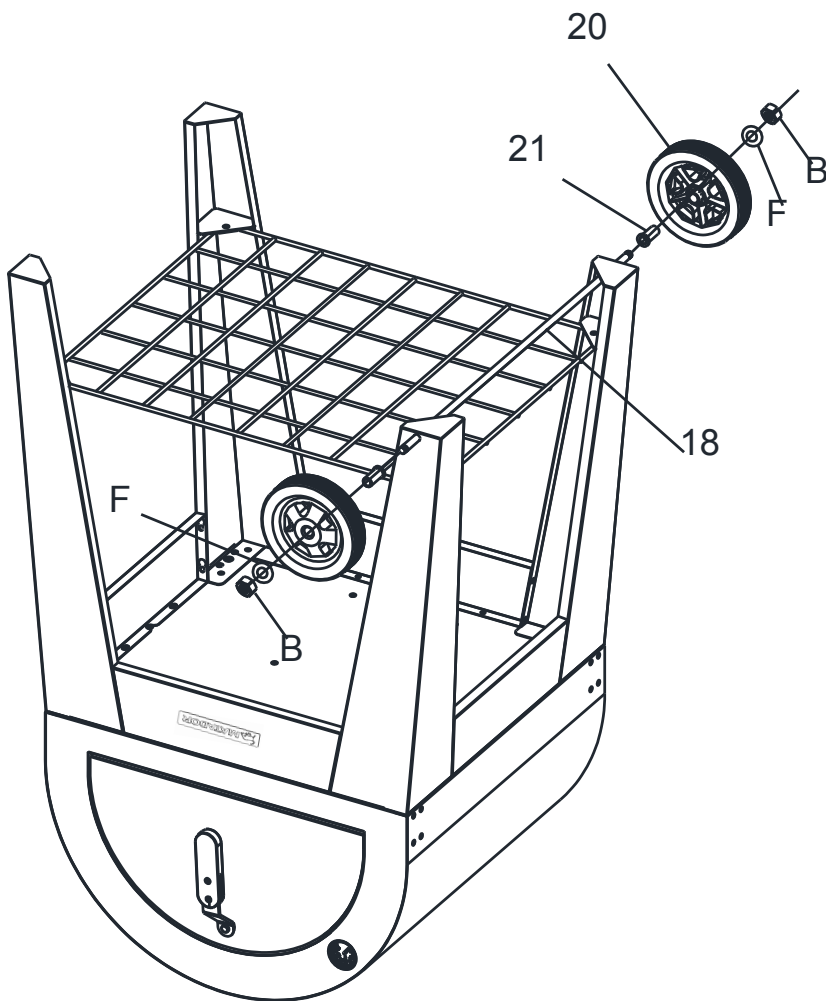

STEP 8

Assemble the back connection bracket for side table (6) and the front connection bracket (7) on the pizza oven by screw (A) 8pcs as shown.

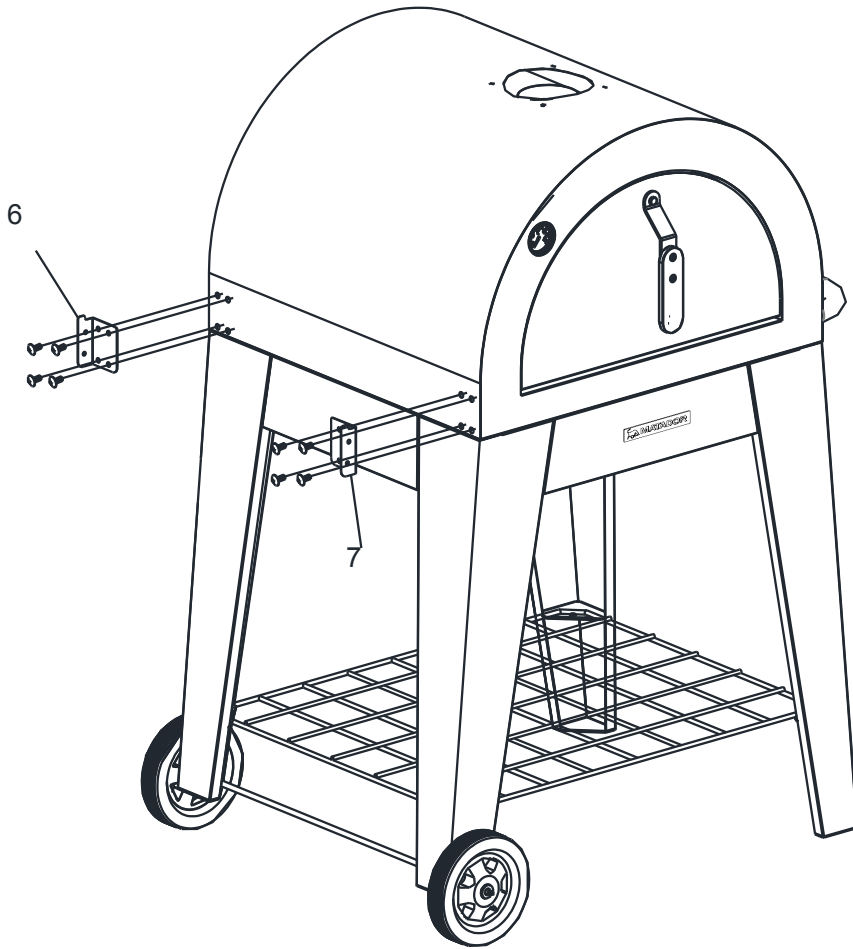

STEP 9

Assemble the side table (5) on the back connection bracket for side table (6) and the front connection bracket for side table (7) by (G) step screw 4pcs and nut (E) 4pcs as shown.

Note: 2pcs (G) step screws and 2pcs nuts are already in position on the brackets of side table (6) & (7).

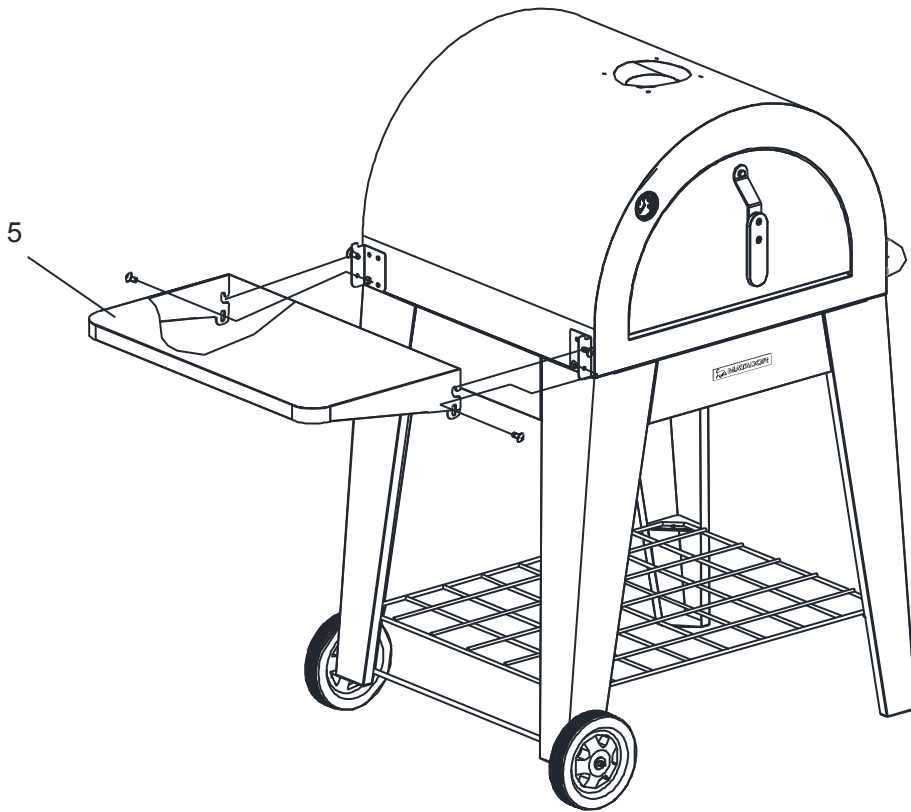

STEP 10

First assemble the chimney cover (2) and the chimney (1) with the 3pcs screw (D) as shown on the right side of the figure below, then fit this assembly to the oven with the 4pcs screw (C) as shown below.

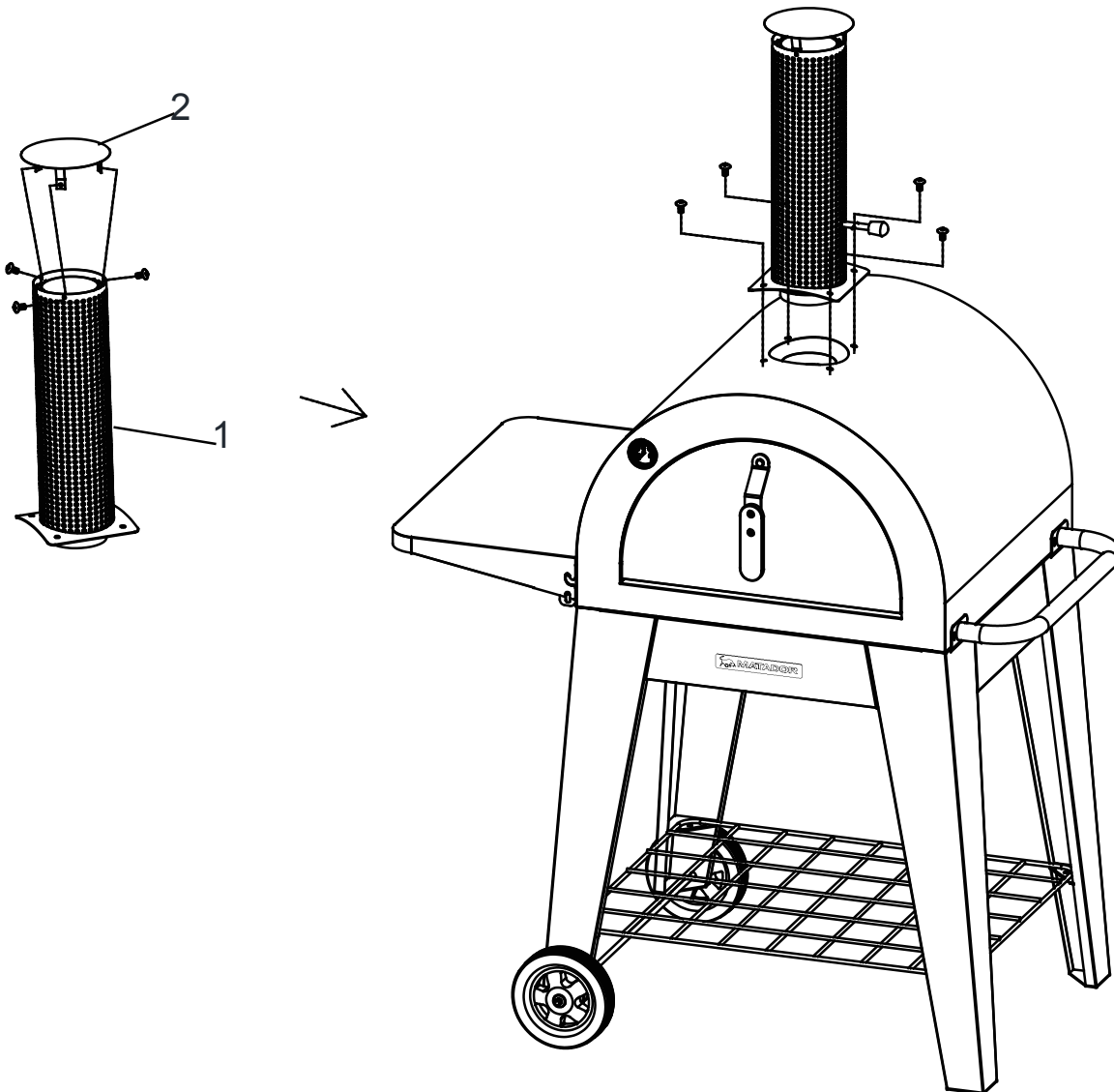

STEP 11

Arrange the bricks (8) (9) and (10) inside the pizza oven as shown below. Note: Put the front row in first and put the back row in second.

Check all the screws are tight.

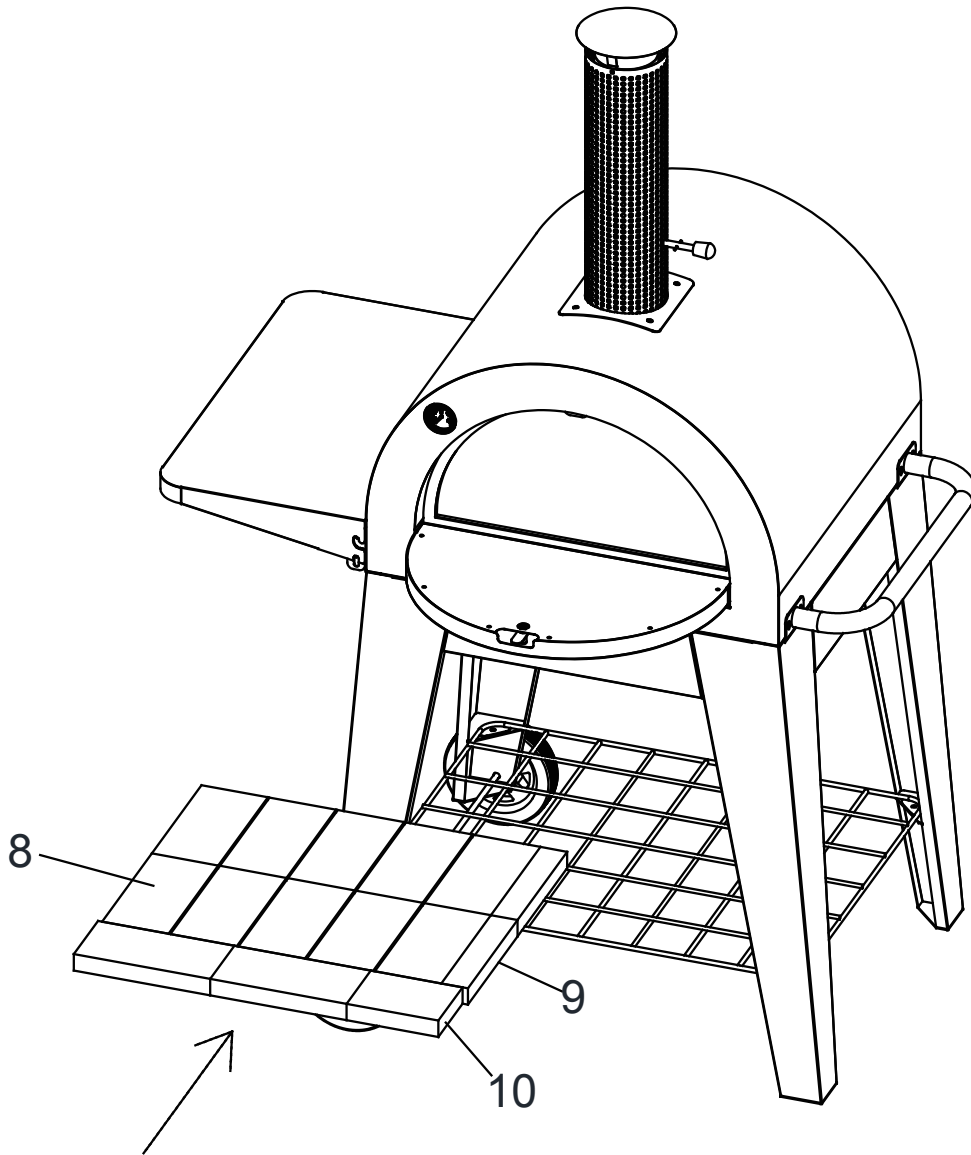

HOW TO USE THE PIZZA OVEN

- Keep a fire extinguisher close by for safety.
- Ensure the oven is not over loaded with firewood and any burning logs cannot roll out.
- Due to the intense heat of the fire, be very careful when operating this oven.
- This oven is intended for cooking pizzas, breads, etc. not as a general wood fire, incinerator or outdoor heater.
- The oven temperature should not exceed the normal cooking temperature where possible. If the normal cooking temperature is exceeded for a long period, the oven has been overloaded with fuel.
- Always add additional logs gradually to ensure not to overload the oven with fuel.
- Overloading the Pizza Oven will void the warranty.
- The door must be closed at all times during the lighting period and when adding additional fuel to the fire. Failure to keep the door closed during these periods will result in discoloration of the fascia.

When lighting your oven, ensure the damper is fully opened in the chimney.

The efficiency of the oven depends on the quality of the fire wood used. Only dry wood should be used as damp wood produces excessive smoke and lower temperatures.

How to light the fire

Prepare the timber in the rear corner of the pizza oven, but don't rest any timber against the inner walls of the oven. Place the fire starter material such as fire lighters or a small amount of paper at the bottom, then kindling (small pieces of timber), and finally one or two logs on top. Light the fire starter material and leave the front door open during the initial fire starting period.

Cooking can commence when a white ash has formed over the timber and the oven temperature has stabilized.



Setting the Oven temperature

Once the fire is burning consistently, add more wood as required gradually. Logs add a large amount of heat so don't add more than one log at any time. Check the oven temperature gauge regularly to maintain the ideal cooking temperature.

The ideal temperature depends on what food you are cooking, for example, bread requires a lower temperature but a longer duration in the oven. We suggest you start cooking pizzas at 200°C to avoid burning your food until you become experienced with your pizza oven.

Chimney Damper Adjustment

The Damper in the chimney is used to control the air flow out of the oven. A fully open damper allows additional air flow which is useful when lighting the fire or when adding fire wood. Slightly closing the damper will reduce the flame size, intensity and heat allowing for more controlled cooking temperature.



Damper in fully open position



Damper in fully closed position

PRODUCT WARRANTY

Thank you for purchasing one of our quality MATADOR products. Your MATADOR product is covered against defects for a period of 2 years for parts and labour, repair or replacement. This warranty excludes surface rust and damage caused by abuse or neglect.

This warranty in Australia is given by Pacific Gas & Heating Pty Ltd, Tel: 1300 793978. Email: info@pacificgas.com.au

The warranty in New Zealand is given by Bunnings NZ Ltd, PO BOX 14436, Panmure, Auckland, 1741.

Tel: 09-9780000 Fax: 09-9782222

Email: marketing@bunnings.co.nz

Any claim under this warranty must be made within 2 years of the date of purchase of the product. Proof of purchase must be presented.

Goods presented for repair may be replaced by refurbished goods of the same type rather than being repaired. Refurbished parts may be used to repair the goods.

FOR AUSTRALIAN CUSTOMERS

To make a claim under the warranty please contact the store where the product was purchased or contact Pacific Gas & Heating Pty Ltd directly.

CONDITIONS OF THE WARRANTY

The warranty covers domestic use only and does not apply to commercial applications. You may submit details and proof to our store for consideration. The warranty covers manufacture defects in materials, workmanship and finish under normal use. This warranty is provided in addition to other rights and remedies you may have under law: our goods come with guarantees which cannot be excluded under the Australian Consumer Law.

You are entitled to replacement or refund for a major failure and to compensation for other reasonably foreseeable loss or damage. You are also entitled to have the goods repaired or replaced if the goods fail to be acceptable quality and the failure does not amount to a major failure.

FOR NEW ZEALAND CUSTOMERS

To make a claim under the warranty, take the product (with proof of purchase) to any Bunnings store (See www.bunnings.co.nz for store locations). This warranty is provided in addition to other rights and remedies you may have under law: our goods come with guarantees which cannot be excluded under the Consumer Guarantees Act 1993(NZ). You are entitled to replacement or refund for a major failure and to compensation for other reasonably foreseeable loss or damage. You are also entitled to have the goods repaired or replaced if the goods fail to be of acceptable quality and the failure does not amount to a major failure.

Goods presented for repair may be replaced by refurbished goods of the same type rather than being repaired. Refurbished parts may be used to repair the goods.

The warranty excludes damage resulting from product misuse or product neglect.

The warranty covers domestic use only and does not apply to commercial applications.



Please thoroughly read conditions of warranty.

- The appliance must be operated and maintained in accordance with the instructions supplied in the operating manual.
- Any repair does not extend the warranty period.
- Any parts other than original MATADOR parts will void this warranty.

INSTALLATION CONDITIONS

- All installations must conform to the applicable Electrical and Building standards as laid down by the local codes or state or region.

WHAT IS NOT COVERED IN THE WARRANTY

- Removal or re-installation costs. This warranty does not cover costs for transit nor in home service.
- Lack of maintenance, abuse, neglect, misuse, accidental or improper installation of this appliance.
- Scratches, dents, corrosion or discolouration caused by heat, abrasive chemical cleaners or chipping.
- Corrosion or damage caused by exposure to the elements such as insects, weather or hail.
- Cleaning and wear and tear; service calls of this nature are chargeable.
- Commercial use of the product.
- Unauthorised repairs or modifications during the warranty period.
- Consumable items, example – heating elements.

RECORD THE FOLLOWING INFORMATION

Attach a copy of the purchase receipt here:

Date of purchase.....

Purchased from.....

Location.....

Model Name and Number.....

Date of Manufacture.....

Receipt number.....

FOR TECHNICAL ASSISTANCE

For Australian customers

If you experience any technical issues with your MATADOR product, in the first instance review the instruction manual or call the warranty service agent below.

For New Zealand Customers

If you experience any technical issues with your MATADOR product, in the first instance review the instruction manual or call your local Bunnings Warehouse.

WARRANTY CLAIMS

For Australian customers

Please contact Pacific Gas & Heating Pty Ltd,
Tel: 1300 793978.

Email: info@pacificgas.com.au

For New Zealand Customers

Please contact the store where the product was purchased.



Visit www.matadorbbqs.com.au

For technical and warranty support call
1300 793 978 (AUS)
09-9780 000 (NZ)

Your purchase receipt will be required for warranty claims.
For spare parts contact Pacific Gas & Heating Pty Ltd.