

STEIN

SELECT VANITY INSTRUCTION MANUAL



0224

IMPORTANT!

1. When you receive your Stein Select Vanity package please check for any freight damage.
2. If damage has occurred, advise your supplier within 8 hours.
3. Do not install any faulty product as this will invalidate later claims.

PLEASE READ CAREFULLY**WARRANTY**

1. This covers faulty product. Check www.stein.co.nz for full details of warranty.
2. Any breakage on site will not be covered.
3. The installation must conform to these instructions for the warranty to apply.
4. Compliance with NZ Building code clause G4 on ventilation is required in a bathroom.
5. Aftercare details in these instructions must be adhered to.

HEALTH AND SAFETY

- Some vanities are heavy and two-man lifting is recommended. Provide support under wall hung units to simplify installation process.
- Determine positioning of wiring and piping within cavity walls. Mark their position to ensure you are protected and services are not damaged.

MATERIALS REQUIRED

- Masking tape
- Bathroom Silicone (Wide adhesion features including plastics)
- Cleaning materials

INSTALLATION TYPE

Wall Hung Vanity Installation: Page 3
 Floor Standing Vanity Installation: Page 4

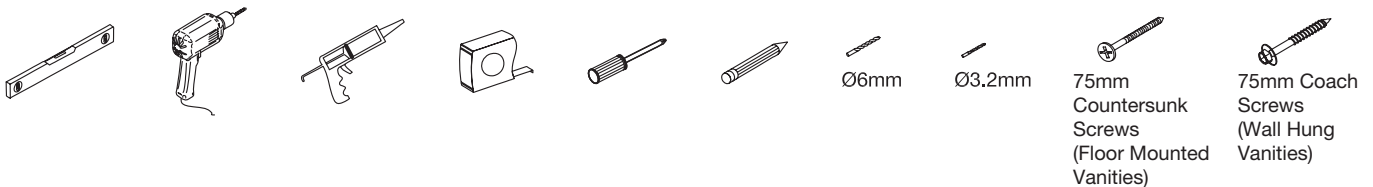
TOOLS REQUIRED

Complete tiling prior to vanity installation. Warranty claims don't cover renewal of wall finishings.

IMPORTANT NOTICE: VANITY INSTALLER, PLUMBER, AND HOUSE OWNER/OCCUPIER

All personnel outlined have specific responsibilities to protect this vanity from water damage. Stein Vanity surfaces are water resistant, but not classified as waterproof.

Vanity Installer

1. Establish solid fastening to the wall.
2. All joints in cabinet, internal edges and cabinet to wall must be sealed.

Plumber

1. Must be a registered plumber with all work to Building Code Compliance.
2. Hot water supply must not exceed 55 degrees.
3. Ensure the water pressure is balanced to the basin size to minimize water splash.
4. Seal all cabinet plumbing penetrations through the cabinet.

House Owner/Occupier

1. Provide a ventilation system that complies with NZ building code G4.
2. Use ventilation when moisture vapour is present in the room.
3. Water from cleaning or spills are dried off without delay with an absorbent cloth.

WARRANTY WILL BE VOID IF THE 'INSTALLATION NOTES' ARE NOT COMPLIED WITH.

- 1 Mark the height (from 800mm to 900mm - owners choice) and locate top and bottom frame points to secure the unit.
- 2 **FASTENING TO THE WALL:** A wall hung vanity needs solid fixing for attachment to the wall. Provide this prior to fixing the wall lining. In some cases, existing framing may be sufficient (Fig 1).

Fig 1

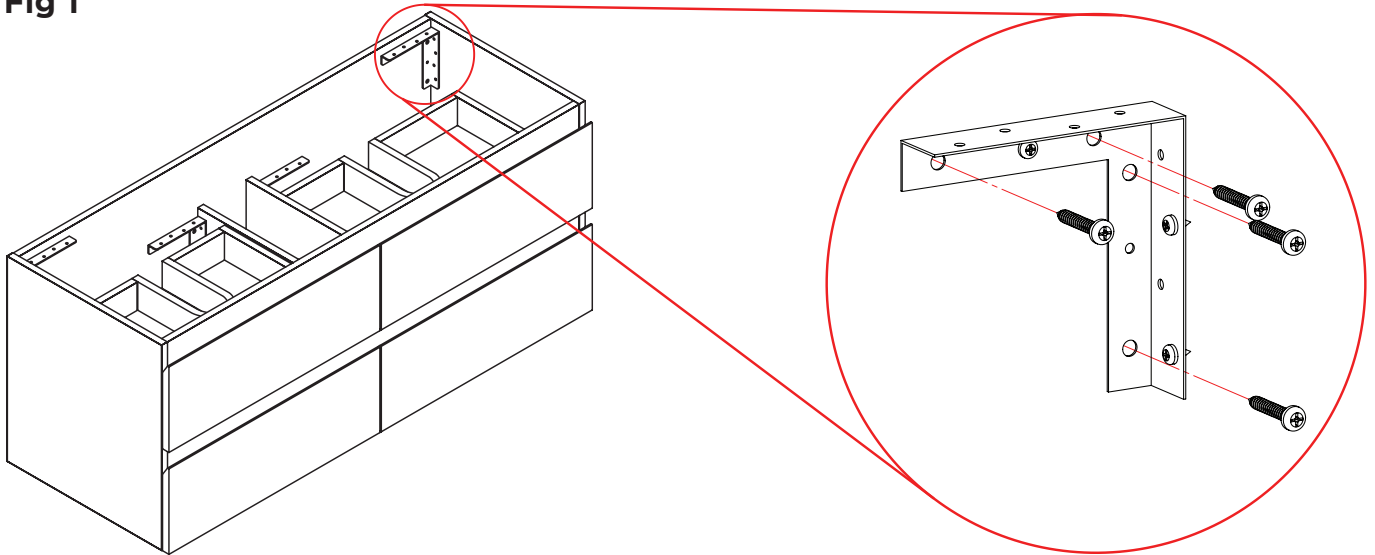

- 3 For installation of pipes it is easier to remove the doors and the drawers. Store them carefully and number their locations (drawer removal and reinstall, page 5).
- 4 Mark and drill holes required for the water and waste fittings.
- 5 Support the unit level at the desired height. Fasten into the frame with heavy gauge wood screws.
- 6 Install the plumbing fittings to meet industry standards. Water test the fittings. Use a registered plumber to complete this task.
- 7 Fit the top in place. This should be flush at the back with even overlaps on each side. Check for any rocking movement to the cabinet (mostly applies to VC tops). Support this movement and apply a bead of silicone to bond these together (Note: There is a 5mm tolerance in VC tops).
- 8 Replace and adjust the doors and drawers. Reference Page 5 if "Soft Close" needs reactivating.
- 9 **SEAL ALL JOINS OF UNIT WITH SILICONE:** Vanity top onto cabinet, top and cabinet to wall and any joints susceptible to water penetration. To achieve an even and tidy finish use masking tape each side of the join.

DO NOT USE FOR 24 HOURS UNTIL SILICONE BOND HAS CURED.

- 1** Check the walls and floors are plumb, level and flat. Take remedial action or compensate for existing discrepancies in the installation process.
- 2** Locate the necessary framework in the wall to fasten the cabinet securely.
- 3** For installation of pipes it is easier to remove the doors and the drawers. Store them carefully and number their locations (drawer removal and reinstall, page 5).
- 4** Screw through the cabinet back panel to wall framing.
- 5** Fit the top in place. This should be flush at the back with even overlaps on each side. Check for any rocking movement to the cabinet (mostly applies to VC tops). Support this movement and apply a bead of silicone to bond these together (Note: There is a 5mm tolerance in VC tops).
- 6** Install the plumbing fittings to meet industry standards and water test the fittings. Use a registered plumber to complete this task.
- 7** Replace and adjust the doors and drawers. Reference Page 5 if “Soft Close” needs reactivating.
- 8** **SEAL ALL JOINS OF UNIT WITH SILICONE:** Cabinet to floor, upstand to wall, cabinet and top to wall and any joints susceptible to water penetration. To achieve an even and tidy finish use masking tape each side of the join.

DO NOT USE FOR 24 HOURS UNTIL SILICONE BOND HAS CURED.

In production there has been two means of fastening the sliding rails to end of draw.

1. Option A - a small countersunk screw is used as indicated on drawing.
2. Option B - if no screw is in place slide both plastic lugs to centre to release.

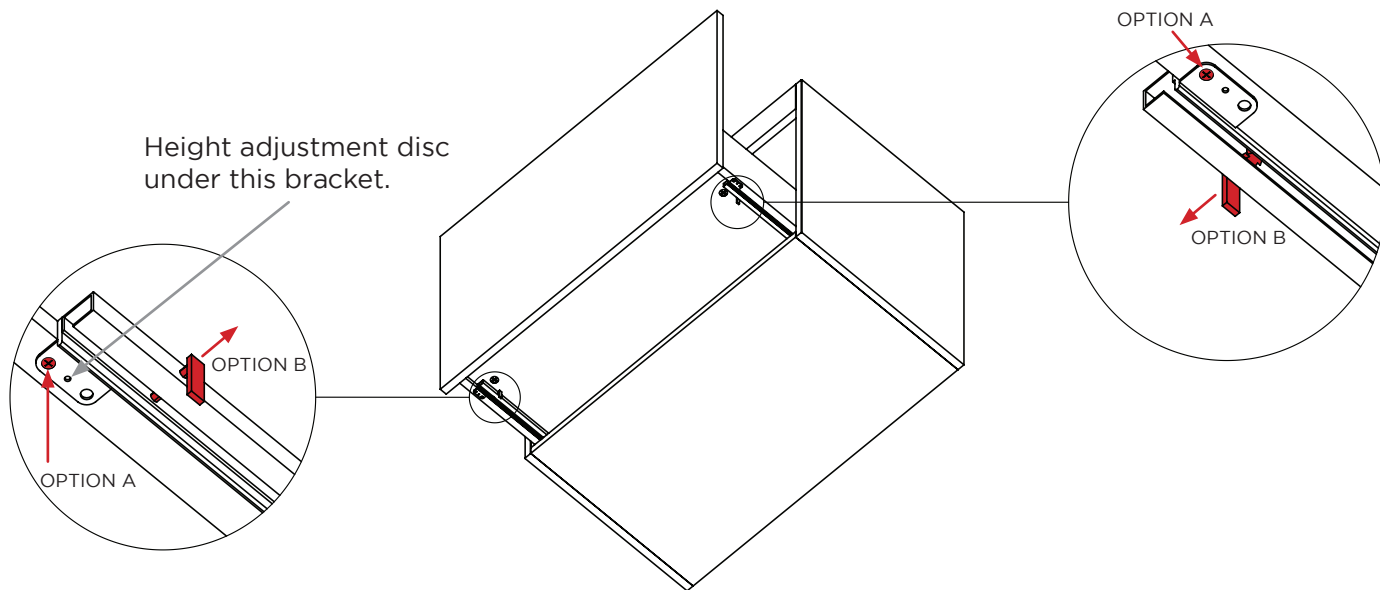

3. Lift drawer up to clear front pin location.
4. Carefully pull draw forward and out.

REINSTALL DRAWER

To reinstall drawer, make sure front and rear pins are engaged. Then reposition lugs into draw body.

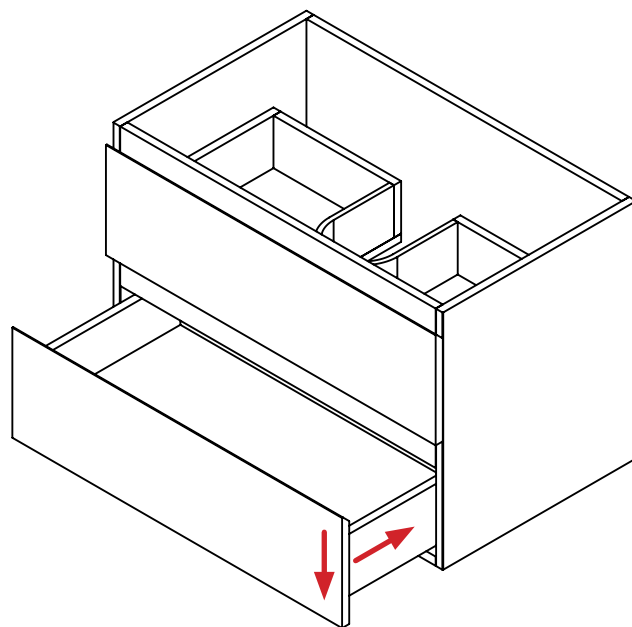
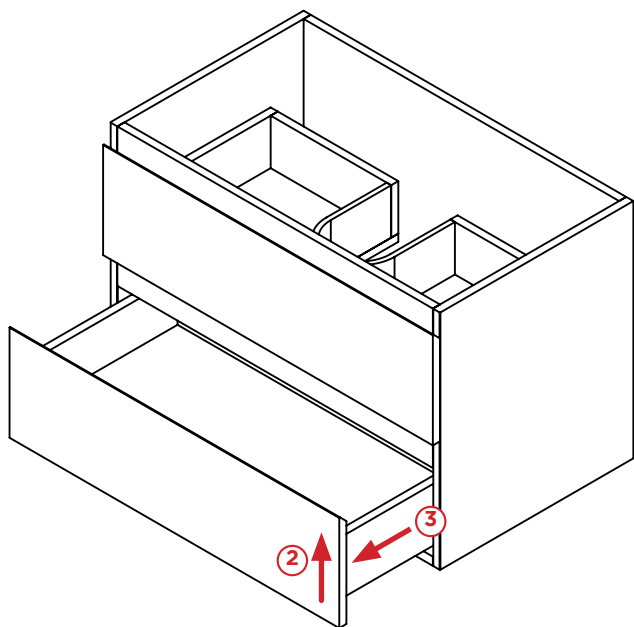

Note: if drawer stops short of closing, this is due to the “soft close” mechanism needing reactivation. Push the drawer shut gently until it clicks. The soft close should now be fully active.

To comply with warranty requirements, please ensure the following aftercare procedures are regularly performed. Failure to comply to Warranty Aftercare Instructions will void warranty.

VITREOUS CHINA BASINS AND VANITY TOPS

- Use warm soapy water or mild detergent and a soft or microfiber cloth. Rinse with clean water. This must be done on a weekly basis or more often when needed.

POLYMARBLE VANITY TOPS

- Use warm soapy water and a clean microfiber cloth followed by drying off with absorbent cloth. This must be done on a weekly basis or more often when needed.
- For minor scuffs on the surface use plastic polish.
- Scratches: If this is minimal use as the process for minor scuffs but in the case of a deeper scratch start with 2000 grit wet and dry paper. Use this wet to take out most of the scratch following on with plastic polish to finish. Note: Deep scratches and chips are best left to a specialised repairer.

VANITY CABINETS

- Laminated or lacquer painted surfaces are water resistant. However constant and excessive exposure to water will enter joins in the assembly and the subsequent damage will be irreversible.
- Ensure the water pressure is regulated and balanced to the size of the basin to control water splash.
- The water temperature must be at a maximum of 55 degrees Celsius.
- The waste connections have been correctly installed by a licenced plumber.
- Any joins in the cabinet that are susceptible for water ingress must be sealed with silicone including cabinet to wall.
- The bathroom must have a suitable ventilation system to remove moisture vapour.
- All cleaning of surfaces: Use a damp microfiber cloth with warm soapy water followed up by drying off with an absorbent cloth.
- Do not use abrasive or aggressive cleaners.
- Installation must comply with instructions to be under warranty.
- Always wipe up any spills immediately.

GENERAL

- A list of chemicals to avoid contact with the surfaces of your product: hair dyes or lacquers, mineral turps, white spirits, insecticides, nail polish or cleaner, bleaches, shoe polish, mercurochrome, iodine, solvents, alcohol, citrus based chemicals, bath oils, bath salts, kerosene. This is by no means comprehensive but indicative of chemical harm that must be avoided.

For further details please refer to the warranty details, available at stein.nz

54 Unutoto Place, Tauriko, Tauranga, 3171

Freephone: 0800 002 299

Phone: 07 928 9990

Email: info@stein.co.nz

stein.nz