



MIMOSA®

Cordoba White Bar Table
Installation Guide

The first part of the document discusses the importance of maintaining accurate records of all transactions. It emphasizes that every sale, purchase, and payment must be properly documented to ensure the integrity of the financial statements. This includes keeping receipts, invoices, and bank statements in a secure and organized manner.

The second part of the document provides a detailed overview of the accounting cycle. It outlines the ten steps involved in the process, from identifying the accounting entity to preparing financial statements. Each step is explained in detail, with examples provided to illustrate the concepts. The cycle is presented as a continuous loop that repeats every year.

The third part of the document focuses on the classification of accounts. It explains how to distinguish between assets, liabilities, and equity accounts, and how to further categorize them into current and long-term items. This classification is essential for preparing the balance sheet and understanding the company's financial position.

The fourth part of the document discusses the recording of transactions. It covers the process of debiting and crediting accounts, as well as the use of T-accounts to visualize the flow of funds. The document provides several examples of how to record common business transactions, such as sales, purchases, and payments.

The fifth part of the document addresses the adjustment of accounts. It explains why adjustments are necessary and how they are recorded. The document covers the four types of adjustments: accrued expenses, accrued revenues, prepaid expenses, and unearned revenues. Each type is explained with a clear example and the corresponding journal entry.

The sixth part of the document discusses the preparation of financial statements. It outlines the steps involved in calculating net income, preparing the income statement, and determining the ending balances for the balance sheet and equity accounts. The document provides a step-by-step guide to ensure that all accounts are properly adjusted and that the financial statements are accurate and balanced.

The seventh part of the document covers the closing process. It explains how to close the temporary accounts (revenues, expenses, and dividends) to the permanent accounts (retained earnings and equity). The document provides the necessary journal entries and explains how the closing process affects the beginning balances for the next accounting period.

The eighth part of the document discusses the importance of internal controls. It explains how to design and implement controls to prevent errors and fraud, and how to monitor the effectiveness of these controls. The document provides several examples of internal controls, such as segregation of duties and regular reconciliations.

The ninth part of the document covers the preparation of the financial statements. It provides a detailed guide to the format and content of the income statement, balance sheet, and statement of equity. The document includes sample financial statements and explains how to interpret the information presented in each statement.

The tenth part of the document discusses the importance of ethical behavior in accounting. It explains how to identify and avoid conflicts of interest, and how to maintain the highest standards of integrity and honesty in all accounting transactions. The document provides several examples of ethical dilemmas and explains how to resolve them.

Cordoba White Bar Table

POWDER COATED ALUMINIUM FRAME

5mm Stone Look Tempered Glass Table Top

ITEM NO. : 0583710

4.

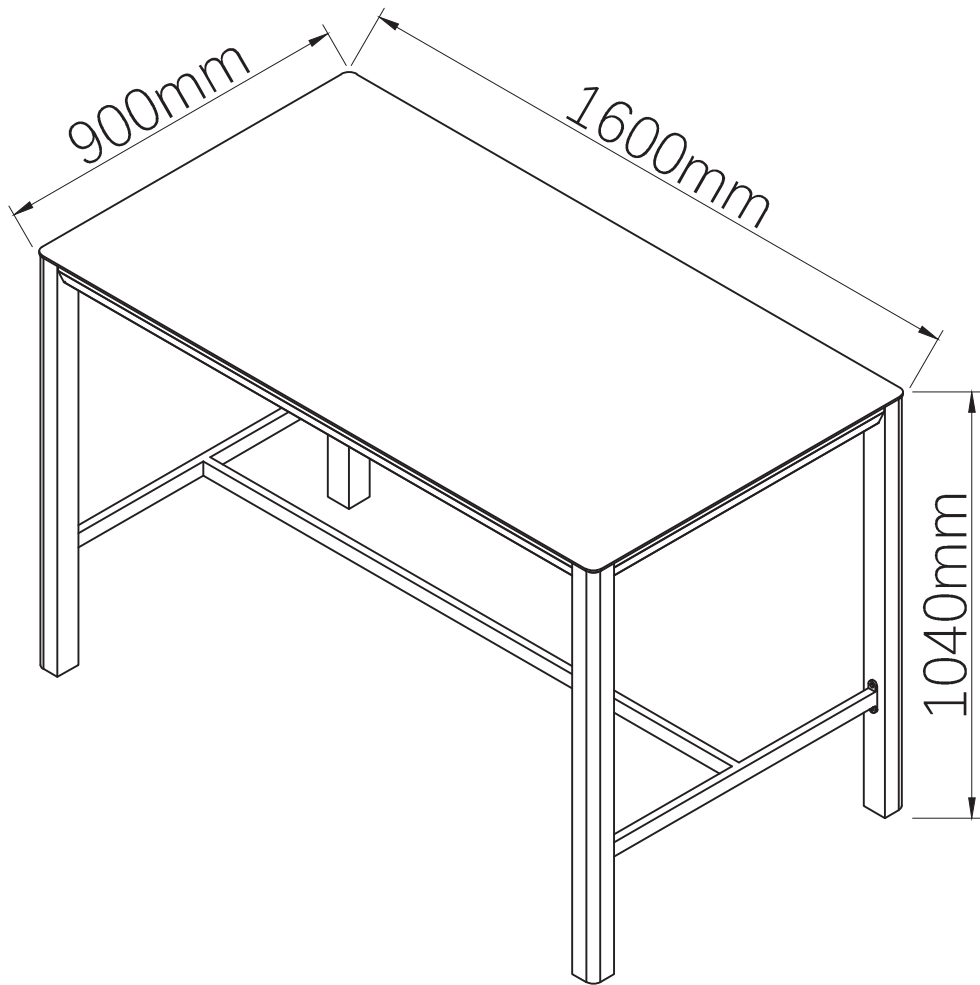



**Please carefully read the below warnings and instructions.
Save the instructions for future reference.**



- Please carefully read all instructions before assembly and use.
- Please separate and identify all parts, ensuring that you have all parts listed.
- Assembly to be carried out by a competent adult.
- During assembly children should be kept away from the product due to possible risk of injury, small parts, and sharp fittings.
- Do NOT use power tools to assemble the product.
- Don't tight all the bolts before the product is fully assembled. Be careful not to over tighten the nuts during assembly.
- Please check the fixings are all tight monthly.

Recommendation





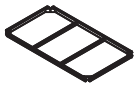
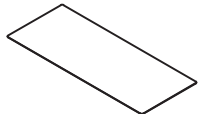
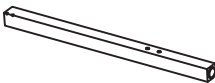



- It would be useful to ask someone to help you assemble the product.
- Retain these instructions for future reference.
- This product is not suitable for extreme weather conditions. Do NOT use in extreme weather condition such as thunderstorm, hailstone, heavy rain, high wind or heavy snow, etc. Warranty claims due to weather events won't be taken into account.
- This piece of furniture has been produced under the best possible conditions and care. However we advise you during constructing or breaking down of this piece of furniture to be aware of sharp metal.
- This product is designed for occasional use only. Do not use as a permanent structure. If no use for long time, dismantle and store safely to prevent any damage occurring.
- If the glass is chipped or broken, stop using the product and consult the manufacturer or supplier.
- Do not place very hot or very cold items on the glass surface(s) unless adequately thick table mats are used to prevent such items from coming into contact with the glass.
- Do not use the glass as a chopping surface. Do not strike the glass with hard or pointed items.
- When cleaning glass panels use a damp cloth or leather with washing up liquid or soft soap if necessary; do not use washing powders or any other substances containing abrasives since these substances scratch glass.
- When using a plastic cover on your furniture, you will need to put an extra cotton medium between this cover and the glass surface. Direct contact between some plastics and the surface of the glass may lead to permanent damage of the table under moist and hot conditions.
- Do not sit or stand upon the glass surface(s).







6.

Parts List:

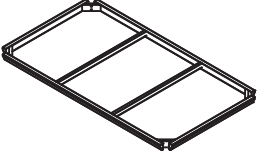
Part No.	Pictures	Description	QTY
A		Table-rack	1
B		Glass table top	1
C		Table leg	4
D		Leg support tube	1

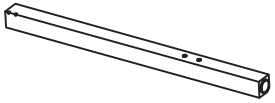
Hardware Kit:

Part No.	Pictures	Description	QTY
E		Bolt M8 x 50 mm	8
F		Washer ø24x8.4x2mm	8
G		Spring washer	8
H		Cap	8
L		Spanner	1
I		Bolt M6 x 20 mm	8
J		Washer ø13x6.5x1mm	8
K		Cap	8
M		Allen Key	1







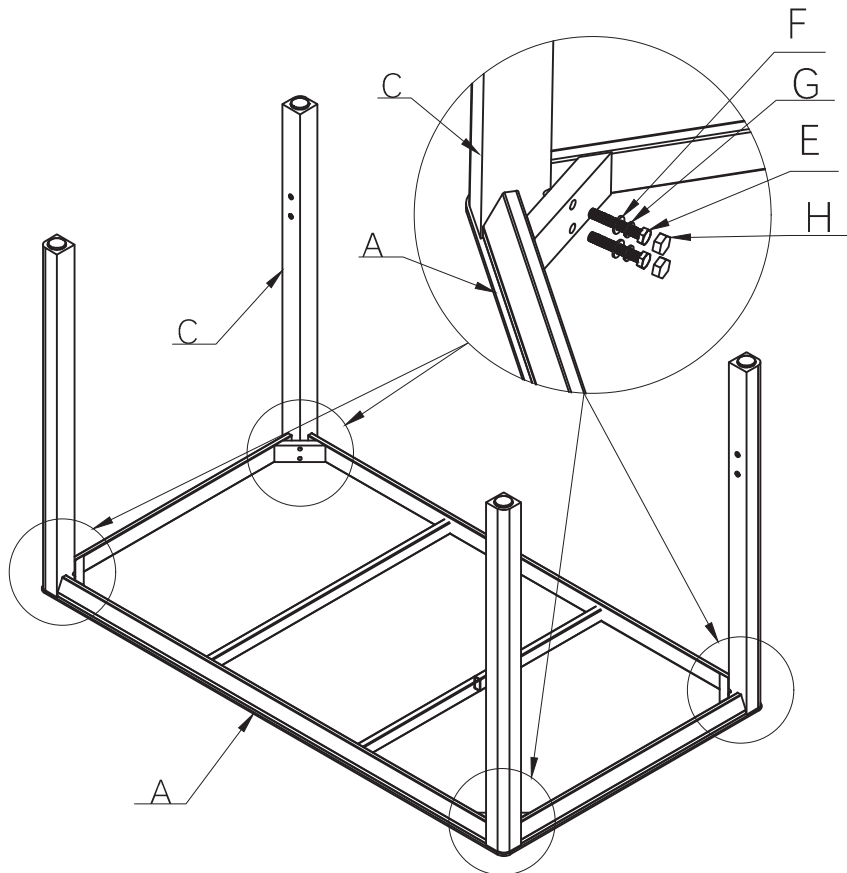



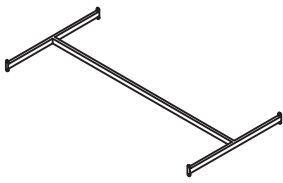

<p>A</p>  <p>x1</p>	<p>E</p>  <p>x8</p>
<p>C</p>  <p>x4</p>	<p>F</p>  <p>x8</p> <p>G</p>  <p>x8</p> <p>H</p>  <p>x8</p> <p>L</p>  <p>x1</p>

Step 1:

Put 4pcs table legs (C) on corner of the table-rack (A), then insert bolts (E), washers (F) and spring washers (G) to the holes, after tightened by the spanner (L), then put plastic caps (H) on the bolts (E).



8.

<p>D</p>  <p>x1</p>	<table><tr><td>I</td><td></td><td>x8</td></tr><tr><td>J</td><td></td><td>x8</td></tr><tr><td>K</td><td></td><td>x8</td></tr><tr><td>M</td><td></td><td>x1</td></tr></table>	I		x8	J		x8	K		x8	M		x1
I		x8											
J		x8											
K		x8											
M		x1											

Step 1:

Put leg support tube (D) on the table legs (C), then insert bolts (I) and washers (J) to the holes, after tightened by the Allen key (M), then put plastic caps (K) on the bolts (I).

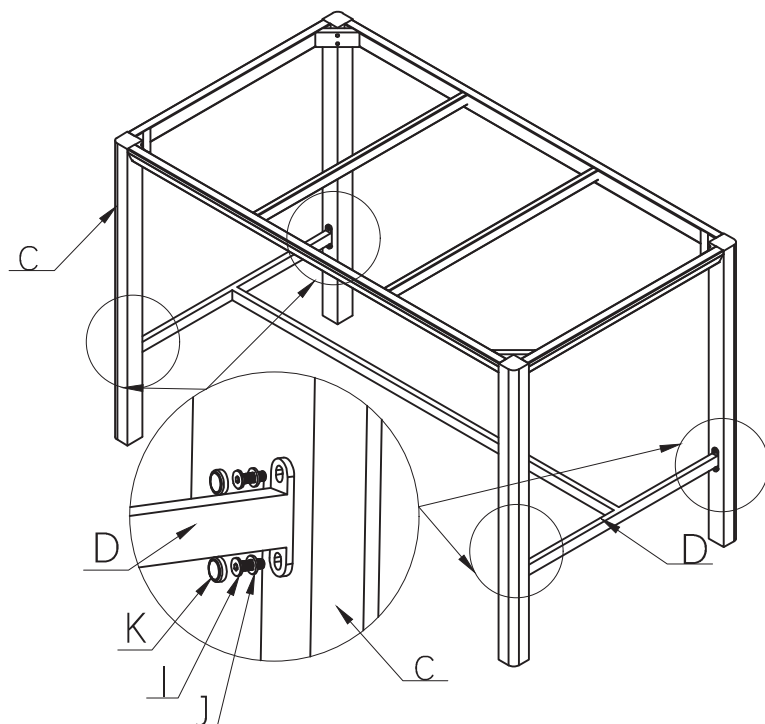

B

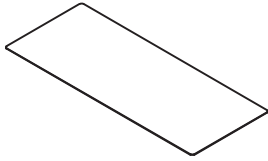

x1

Step 3:

Put the glass table top (B) on the table-rack (A).

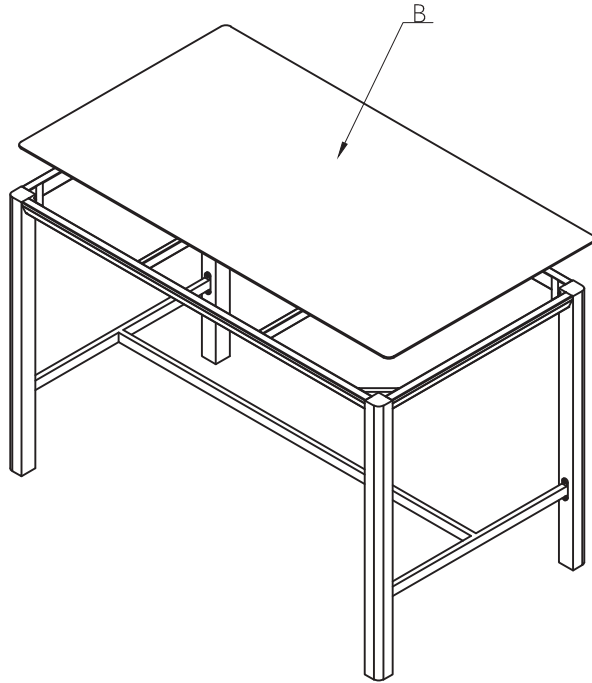

Bar table is now ready for use.

