



MIMOSA®

Cordoba White Bench
Installation Guide

The first part of the document discusses the importance of maintaining accurate records of all transactions. It emphasizes that every entry, no matter how small, should be recorded to ensure the integrity of the financial data. This includes not only sales and purchases but also expenses and income. The document provides a detailed explanation of how to categorize these transactions and how to use a double-entry system to ensure that the books are balanced. It also discusses the importance of regular audits and how to identify and correct errors before they become significant.

The second part of the document focuses on the practical aspects of bookkeeping. It provides a step-by-step guide to setting up a ledger and how to enter transactions. It also discusses the importance of keeping the books up to date and how to use the information to make informed business decisions. The document includes several examples of how to record transactions and how to calculate the profit and loss for a business. It also discusses the importance of keeping the books secure and how to protect the information from unauthorized access.

The third part of the document discusses the importance of maintaining accurate records of all transactions. It emphasizes that every entry, no matter how small, should be recorded to ensure the integrity of the financial data. This includes not only sales and purchases but also expenses and income. The document provides a detailed explanation of how to categorize these transactions and how to use a double-entry system to ensure that the books are balanced. It also discusses the importance of regular audits and how to identify and correct errors before they become significant.

Cordoba White Bench

POWDER COATED ALUMINIUM FRAME

Light Weight Design

ITEM NO. : 0583697

4.

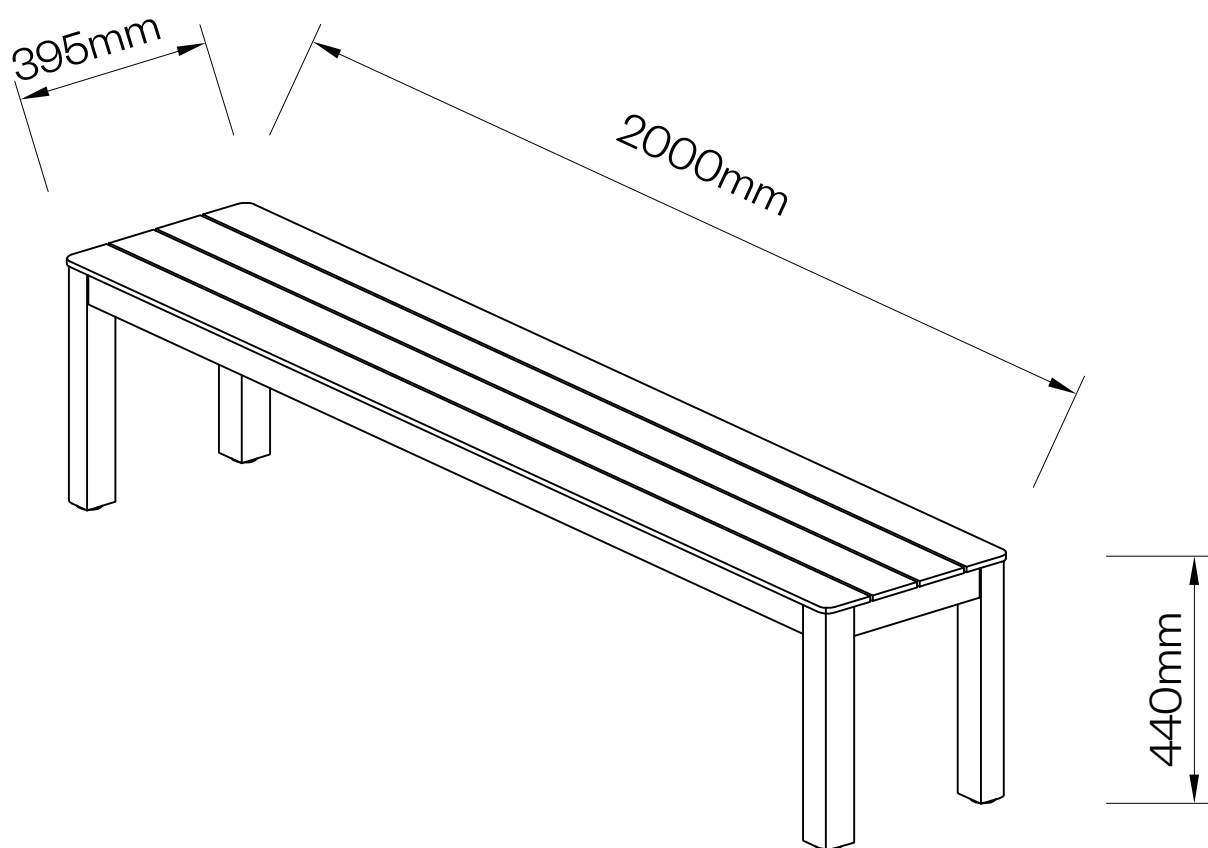



**Please carefully read the below warnings and instructions.
Save the instructions for future reference.**

- Please carefully read all instructions before assembly and use.
- Please separate and identify all parts, ensuring that you have all parts listed.
- Assembly to be carried out by a competent adult.
- During assembly children should be kept away from the product due to possible risk of injury, small parts, and sharp fittings.
- Do NOT use power tools to assemble the product.
- Don't tight all the bolts before the product is fully assembled. Be careful not to over tighten the nuts during assembly.
- Please check the fixings are all tight monthly.

Recommendation



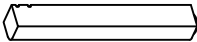

- It would be useful to ask someone to help you assemble the product.
- Retain these instructions for future reference.
- This product is not suitable for extreme weather conditions. Do NOT use in extreme weather condition such as thunderstorm, hailstone, heavy rain, high wind or heavy snow, etc. Warranty claims due to weather events won't be taken into account.
- This piece of furniture has been produced under the best possible conditions and care. However we advise you during constructing or breaking down of this piece of furniture to be aware of sharp metal.
- This product is designed for occasional use only. Do not use as a permanent structure. If no use for long time, dismantle and store safely to prevent any damage occurring.
- The maximum weight / load of this product is 300kg.
- Wipe clean with damp cloth only using detergent & lukewarm water.

6.

Parts List:

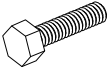
Part No.	Pictures	Description	QTY
A		Seat frame	1
B		Leg	4

Hardware Kit:

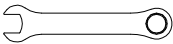
Part No.	Pictures	Description	QTY
C		Bolt M8 x 50 mm	8
D		Washer	8
E		Spring washer	8
F		Spring washer	8
G		Spring washer	1

<p>A x1</p>	<p>C x8</p>
<p>B x4</p>	<p>D x8</p>
	<p>E x8</p>
	<p>F x8</p>
	<p>G x1</p>

Step 1:

Put 4pcs legs (B) on the corner of the seat frame (A), inserting bolts (C) with washers (D) and spring washers (E) to the holes, then tighten all bolts with spanner (G) one by one. Cover the caps (F) on the bolts (C) at last.

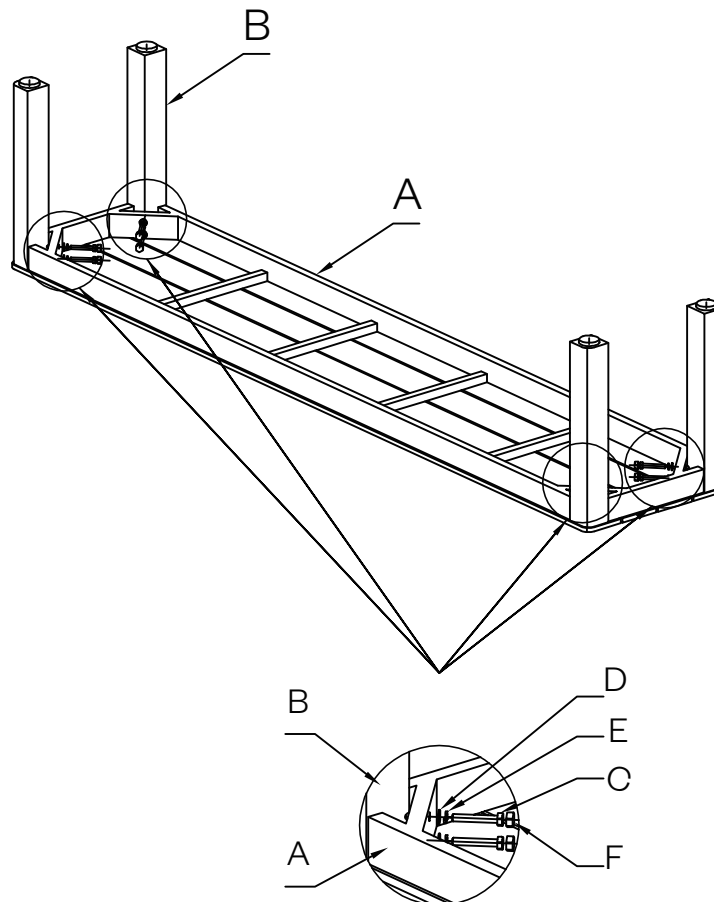

8.

Step 2:

Bench is now ready for use.

