

1.Exploded drawing

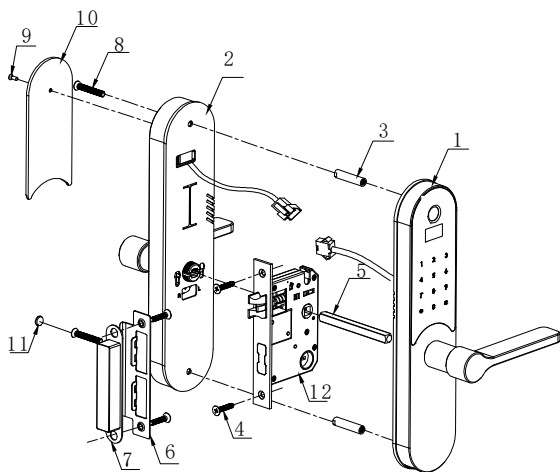

| No. | Part name | Qty |
|-----|--------------------------------|-----|
| 1 | Front plate components | 1 |
| 2 | Back plate components | 1 |
| 3 | M5 x M6 x 35 screw bolt | 2 |
| 4 | M4 x 25 countersunk head screw | 4 |
| 5 | Spindle | 1 |
| 6 | Strike plate | 1 |
| 7 | Strike plate box | 1 |
| 8 | M5 x 35 screw | 2 |
| 9 | M3 x 6 screw | 1 |
| 10 | Battery box cover | 1 |
| 11 | Screw cap | 1 |
| 12 | Mortise | 1 |

2.Product dimensions

2.1 Front panel

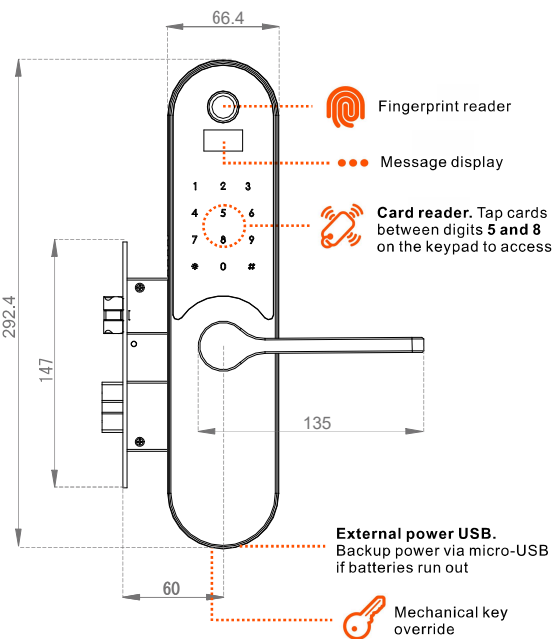

2.2 Back panel

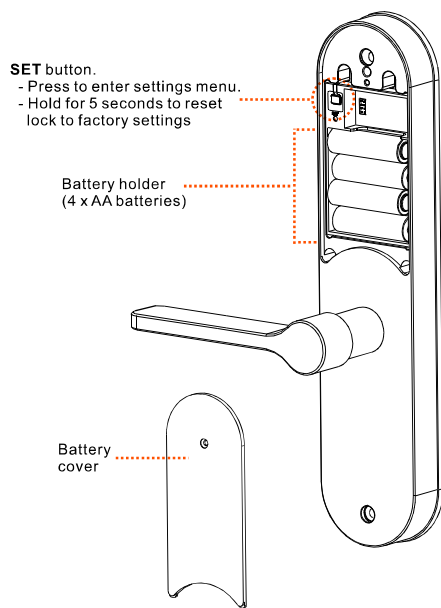

3.Installation steps

3.1 Identify the opening direction before installation.

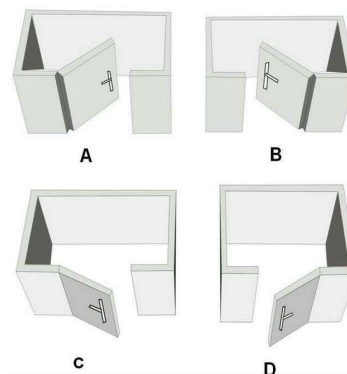

3.2 Depending on door opening direction, orientate the latch as required to align with the strike plate. (1)

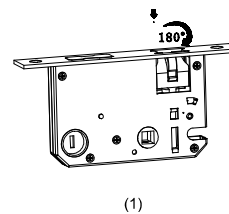

3.3 Change direction of the handle as required.

Front handle:

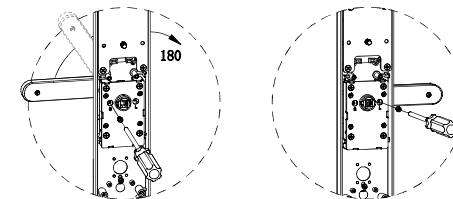

Step 1: Unload and remove the reversing screw (on R or L side). Rotate handle by 180 degrees.

Step 2: Fasten the reversing screw to the opposite side

Back handle: Unload and remove the middle handle screw. Rotate handle by 180 degrees and fasten.

3.4 Put the mortise into the hole and keep the latch bolt upwards. Then fasten the mortise lock with screws. (2)

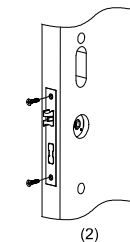

3.5 Push the spring in and fix the spindle to the clutch on front plate. (3)

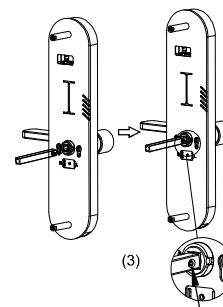

3.6 Put the bus bar end of the cable through the door hole from outside to inside door and put the spindle into the hole. (4) & (5)

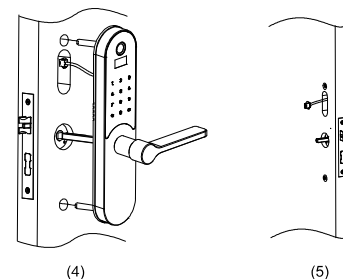

3.7 Connect the cable of back plate with the bus bar end of the cable. Align the back handle to the spindle and fix the back plate with screws. (6) & (7) & (8)

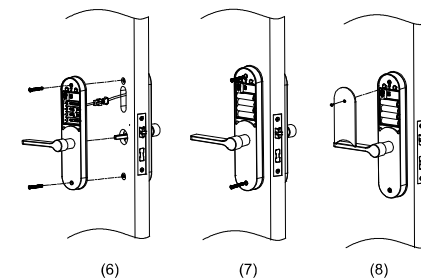

3.8 Put the strike plate cup and strike plate in right place and fasten them with screws. (9)

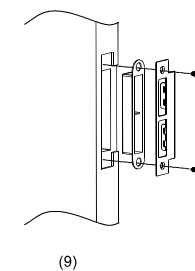

For installation video instructions:



**EASY TO
INSTALL
STEP-BY-STEP
INSTRUCTIONS**

4.8 Other settings

Other settings includes Passage mode, Double unlock, voice setting and time setting.

a. Passage mode

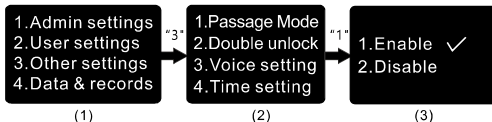

b. Double unlock

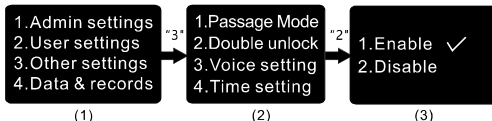

c. Voice setting

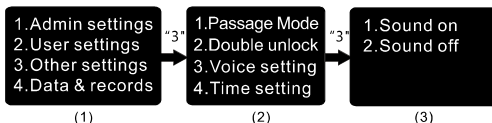

d. Time setting

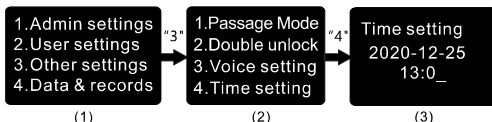

Time setting must be yyyy-mm-dd format for date and 24 hr clock for time.

4.10 Factory reset

Long press the SET button behind battery cover for 5 seconds to perform a factory reset (a voice prompt heard upon a successful reset). All unlock records, passwords and saved data will clear. **Note:** Passwords will return to default and any fingerprint or card will be able to access the lock.

4.11 Lock sync

To synchronise the lock with the cloud (once Wi-Fi has been set up) press "9" then "#" on the touch panel. This function is used to sync data generated in the Grid Connect app (e.g. quick code or scheduled access). Syncing the lock can take anywhere between 3-15 seconds depending on Wi-Fi strength and connection.

Syncing the lock will also send an unlock request to a connected device if the Grid Connect app is open.

4.12 Other functions

- Keypad lock:** The touch panel will be locked and inactive for 90 seconds if the password is entered incorrectly 5 times.
- Scramble function:** Add random numbers before and/or after a valid password and press "#" to unlock (e.g. 1234 "valid password" 1234 "#"). The total length of the scramble password should be less than 19 digits.
- Sleep:** The display will turnoff and enter sleep mode after 10 seconds of inactivity
- Low battery alarm:** The lock will alarm when unlocked every time when the voltage is lower than 4.8V. The lock still can be unlocked for extra 200 times after 1st alarm. Please change the batteries in time after the 1st alarm.
- External power USB interface:** Connect power bank to bottom of the front panel to gain power when the batteries are not changed in time.
- Passage mode alert:** When Passage mode is enabled, there will be a voice notice when unlocking and locking the door.

4.9 Data & records

a. Records query

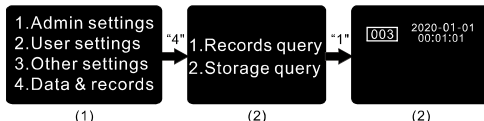

b. Storage query

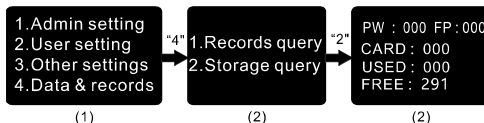

4.13 Specifications

| | |
|----------------------|----------------------------------|
| Power supply | 4 x 1.5V AA alkaline batteries* |
| Static current | < 50uA |
| Rating current | < 250mA |
| Capacity | 300 lds (Max 9 Admin + 291 User) |
| Fingerprint capacity | 100 |
| Card type | Mifare card |
| Operating temp. | -10°C - 60°C |
| Relative humidity | 20% - 85% |

*Battery life will vary depending on usage, environment and battery quality. It is suggested to use high quality batteries.

4.14 Warranty

For product warranty details, please refer to the Warranty section at www.lemaar.com.au/smart-lock-range

Fingerprint Smart Lock Mobile Application

5. Mobile application and Wi-Fi setup

5.1 Download mobile app

Download the **Grid Connect** app from the Apple App Store or the Google Play Store, or scan the QR code below.

Note: App updates may cause some of the following instructions to vary, and there may be small differences between iOS and Android devices.



5.2 Account Registration

1. Once the Grid Connect app has been downloaded and installed, tap '**create new account**' and follow the on-screen prompts including to agree to the privacy policy. If you already have an account you can '**login to account**'.

2. If registering for the first time, please use your current email address. The country/region of the app will be the same as the country/region in your phone settings. Enter your email and press **Get Verification Code**.

Enter the verification code (sent to your provided email address) and set your password in the next screen. Press **Next** and allow the app to access your location by pressing the **Allow** button.

You are now ready to add the lock and pair with the app!

Visit the Grid Connect website for further Online Assistance or contact the Grid Connect Customer Service Team if you are unsure of how to pair or use your lock.



4.10 Factory reset

Long press the SET button behind battery cover for 5 seconds to perform a factory reset (a voice prompt heard upon a successful reset). All unlock records, passwords and saved data will clear. **Note:** Passwords will return to default and any fingerprint or card will be able to access the lock.

4.11 Lock sync

To synchronise the lock with the cloud (once Wi-Fi has been set up) press "9" then "#" on the touch panel. This function is used to sync data generated in the Grid Connect app (e.g. quick code or scheduled access). Syncing the lock can take anywhere between 3-15 seconds depending on Wi-Fi strength and connection.

Syncing the lock will also send an unlock request to a connected device if the Grid Connect app is open.

4.12 Other functions

- Keypad lock:** The touch panel will be locked and inactive for 90 seconds if the password is entered incorrectly 5 times.
- Scramble function:** Add random numbers before and/or after a valid password and press "#" to unlock (e.g. 1234 "valid password" 1234 "#"). The total length of the scramble password should be less than 19 digits.
- Sleep:** The display will turnoff and enter sleep mode after 10 seconds of inactivity
- Low battery alarm:** The lock will alarm when unlocked every time when the voltage is lower than 4.8V. The lock still can be unlocked for extra 200 times after 1st alarm. Please change the batteries in time after the 1st alarm.
- External power USB interface:** Connect power bank to bottom of the front panel to gain power when the batteries are not changed in time.
- Passage mode alert:** When Passage mode is enabled, there will be a voice notice when unlocking and locking the door.

4.13 Specifications

| | |
|----------------------|----------------------------------|
| Power supply | 4 x 1.5V AA alkaline batteries* |
| Static current | < 50uA |
| Rating current | < 250mA |
| Capacity | 300 lds (Max 9 Admin + 291 User) |
| Fingerprint capacity | 100 |
| Card type | Mifare card |
| Operating temp. | -10°C - 60°C |
| Relative humidity | 20% - 85% |

*Battery life will vary depending on usage, environment and battery quality. It is suggested to use high quality batteries.

4.14 Warranty

For product warranty details, please refer to the Warranty section at www.lemaar.com.au/smart-lock-range

5.3 Pairing the lock with the mobile app (basic Instructions)

Step 1:

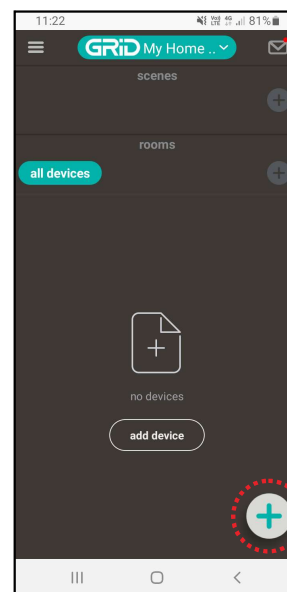

Once logged in to your Grid Connect account, tap '**add device**' or '+' icon to open the add device menu.

Step 2:

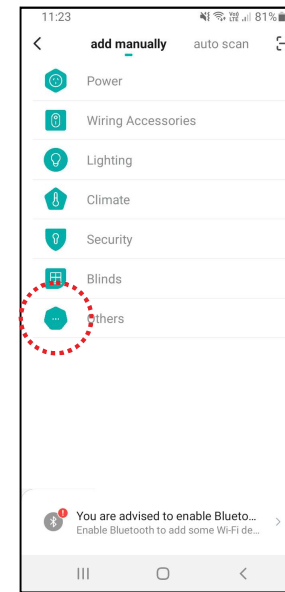

At the add device menu, choose the **Others** category at the bottom of the list.

Step 3:

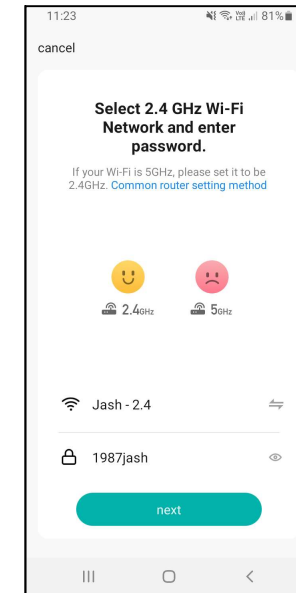

Enter your Wi-Fi details and password. Network must support 2.4GHz.

**** Please contact Grid Connect customer support if you need help pairing.****

Step 4:

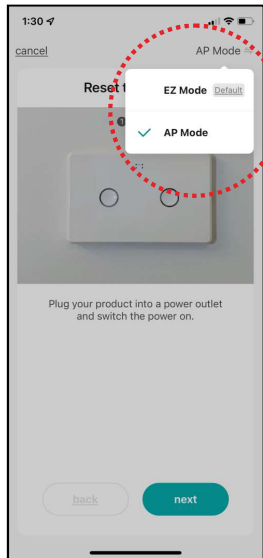

Tap 'EZ mode' at the top of the screen and select 'AP Mode'. Follow the on-screen prompts (tap "next") until you get to the 'go connect' page (refer Step 5)

Step 5:

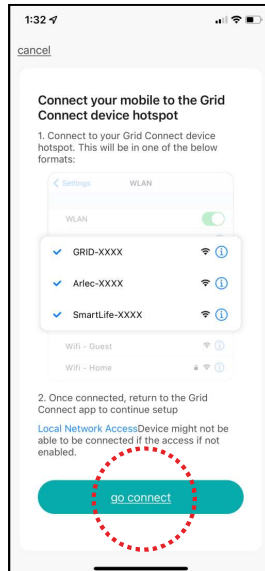

Before proceeding further, follow the adjacent "Pairing with the lock" instructions. Navigate back to this page in Step 5c.

Pairing with the lock:

Step 5a: Ensure lock has been reset to factory settings (refer section 4.10 for guidance)

Step 5b: Enable Wi-Fi pairing on the lock through the lock's settings:

- i. Access the lock's settings by inputting Admin information (000000) into the keypad.

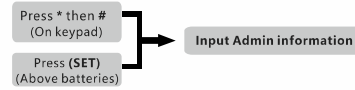

- ii. Select Wifi settings then Enable pairing.

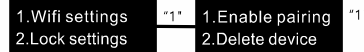

The lock is ready to pair once the **Wait adding...** search screen appears on the lock's LCD panel.

Step 5c: While the lock is searching for a device, reopen the mobile app and select **go connect**.

This will take you to the Wi-Fi settings in your phone, connect to the hotspot marked SmartLife-XXXX where XXXX is alpha-numeric. Once connected to this hotspot (e.g. connected without internet), return back to the Grid Connect app which will now automatically try to pair to your lock.

6. Basic app functions and operations.

6.1 Setting a quick code

Step 1:

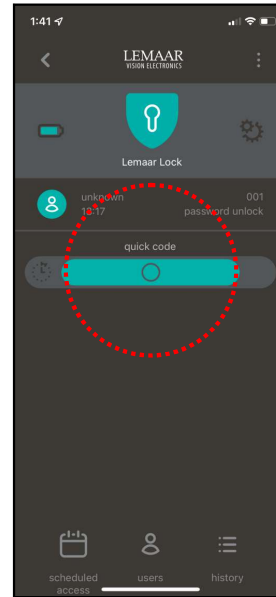

Tap on the green bar beneath 'quick code'

Step 2:

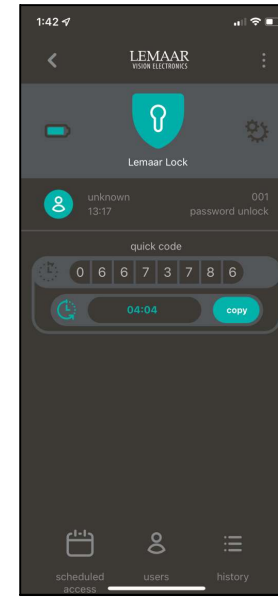

An 8 digit code will be generated which will invalidate after 5 minutes.

Step 3:

Tap 'Copy' to copy the password to your mobile phone's clipboard. This can then be pasted and shared as a text message, WhatsApp message etc.

Step 4 (at the lock):

Before any quick code can be used, the lock must first be synced by pressing "9" then "#" on the keypad to update the lock data.

It is suggested to sync the lock as soon as the password is set or request the user to simply press "9" then "#" before inputting their quick code. (Please note that syncing the lock will also send a **remote unlock request** to the app)

What is a remote unlock request?

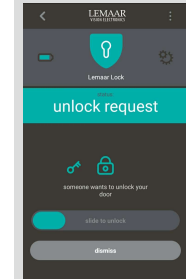

A remote unlock request is sent when "9" then "#" is input into the lock's keypad.

This will sync the lock but also send a message to a paired mobile device to unlock the lock.

To unlock remotely, the user receiving the request must have the main device page open in the Grid Connect app.

Step 6:

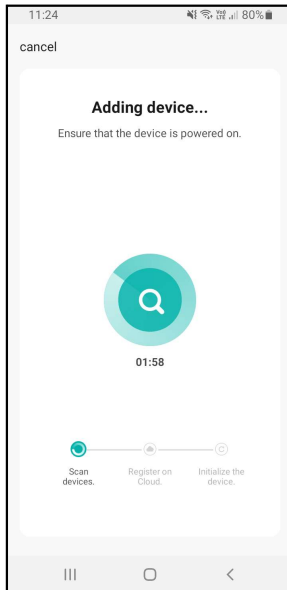

The app will now attempt to pair with the lock. If pairing fails, tap **Retry** and restart the process from Step 3. **Tip:** Make sure 'AP mode' is selected as shown at Step 4.

Step 7:

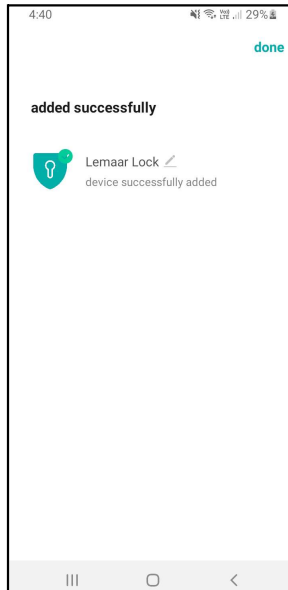

An **added successfully** screen will show once completed. Press **Done**.

****Congratulations! You have successfully paired the lock.****

Step 8:

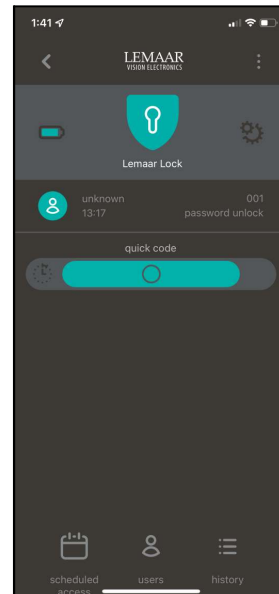

The app will then open the device home page. Manage all mobile based features of the lock from this screen (Refer section 6). A lock icon will also now be accessible from the Grid Connect dashboard.

6.2 Setting scheduled access

Step 1:

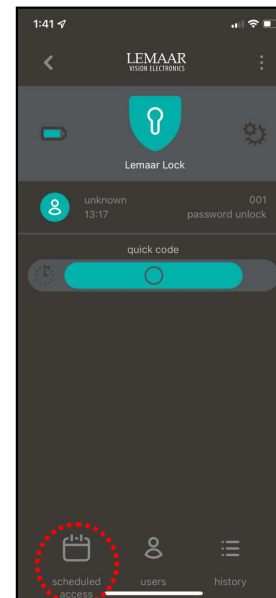

Tap the **scheduled access** icon at the bottom left of the device page.

Step 2:

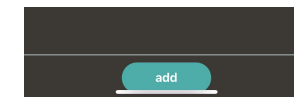

For the initial use, press **Add** (bottom of screen) to open the scheduled access settings page.

Step 3:

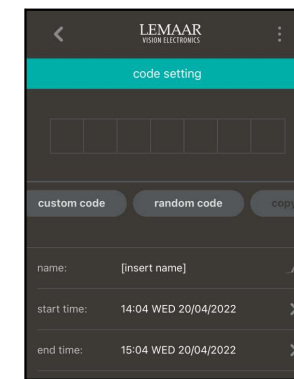

At the Code Setting page, select '**custom code**' to input a 7 digit password or generate a random code by tapping the '**random code**' button.

Complete the other required details such as **Name** (e.g Plumber), **start time** (start date/time), and **end time** (end date/time).

Once details are completed and have been automatically validated (e.g the start date is not later than the end date), press **Done**. You can also copy the scheduled access code by tapping '**copy**'.

Step 4:

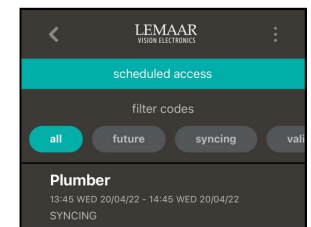

The scheduled access page will now show all current passwords and their status. To add more scheduled access codes, press the "**add**" on the bottom corner of the screen.

Step 5 (at the lock):

Before scheduled access can be used, the lock must first be synced by pressing "9" then "#" on the keypad to update the lock data (same as quick code)

Please note: Quick codes and scheduled access codes are fully removed after the lock is synced.

6.3 Users (adding users to the app)

Once Admins and Users have been added to the lock (refer section 4.5 and 4.6) and Wi-Fi has been setup, new users can be added to use the app and user details recorded as "members".

There are 2 types of members, **app users** and **primary users**:

a. app user:

An app user has shared access within Grid Connect, they are able to access features such as temporary access codes, history and alerts as well as have fingerprints, codes and tags assigned to them.

Note: In order to add an app user, they must have a Grid Connect app and account.

b. primary user

A primary user is only added to record their details with a door event.

For example, if a User X's user IDs are 002 for fingerprint, 003 for key card and 004 for password, these details can be recorded under User X's profile in your app under a primary user.

Then, when User X opens the lock, it will show in the **'History'** page as "User X" instead of "unknown".

Not sure what your user IDs are? Unlock the door and check the ID number on the screen, or refer to the History section of the Grid Connect app. Remember that each entry method will have its own ID.

Tip: Record User IDs in section 4.7 when adding Admins or Users to the lock and conveniently assign them to users in the Grid Connect app when ready.

Step 1: Adding users to the app:

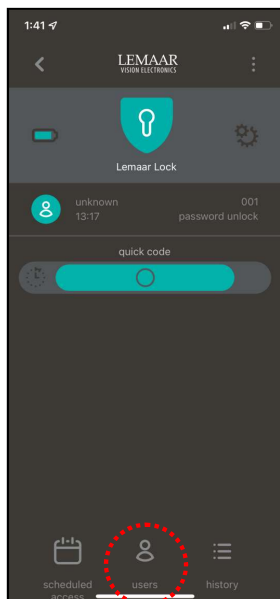

Tap the **Users** icon at the bottom of the device page.

Step 2:

In the **Users** page, tap on the icon to add new **primary** or **app** users.

In the next "user type" page (see below), select the type of user you want by tapping **+** to add and follow the on screen prompts.

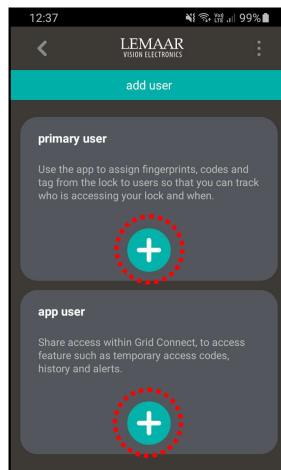

For more information on adding Users, visit grid-connect.com.au

7. Troubleshooting and notes

7.1 Troubleshooting (general)

| Problem | Possible Causes | Suggested Remedy |
|---|--|--|
| Minor scratches or abrasions on panels. | Protective film not yet removed | Carefully remove protective film. |
| No response on the keypad after installation. | (1) The keypad connector cable is disconnected. (2) Batteries are flat or incorrectly installed. | (1) Check and ensure connector between front and rear door handle is properly plugged in and connected. (2) The door lock can be powered from the micro-USB port, by using a standard micro-USB cable and a power bank. (3) If the door lock worked with the power bank, remove Phillips head screw holding battery cover in place. Ensure batteries are installed correctly; if they were, replace batteries and refit cover. |
| Low battery warning. | Batteries are almost flat. | Remove Phillips head screw holding battery cover in place. Replace batteries and refit cover. |
| Door is locked and batteries are confirmed flat. | | (1) Manually unlock the door by inserting and rotating the supplied key into the key barrel located at the bottom of the lock. Turn handle to open door. (2) The door lock can be powered from the micro-USB port, by using a standard micro-USB cable and a power bank. |
| Alarm activated, cannot unlock door, countdown timer displayed on screen. | Too many incorrect attempts to unlock the door. | (1) Wait 90 seconds for the lock timeout to expire. The timer is visible on the lock display. Once expired, use the correct passcode, fingerprint or swipe card to unlock successfully. (2) Manually unlock the door by inserting and rotating the supplied key into the key barrel located at the bottom of the lock. Turn handle to open door. |
| The door is not automatically locking after 5 seconds from correct password? | Lock is in Passage Mode | Using the instructions provided, ensure passage mode is disabled. Lock settings > Other settings > Passage mode > Disable |
| The Deadbolt will not come out of the lock body when I lift the handle up. | (1) The spindle is not installed. (2) The strike is not aligned correctly. (3) The Lock Body has failed. | (1) Check Spindle is installed correctly using the instructions provided. (2) Check Strike alignment. (3) Contact Customer support. |
| The Key Override does not work. | The Override Key is not turning in the keyway. | (1) Check that the key is being fully inserted prior to turning. (2) Visually inspect the key for damaged. (3) Check that the key is being turned in the correct direction. |

6.4 History

Step 1:

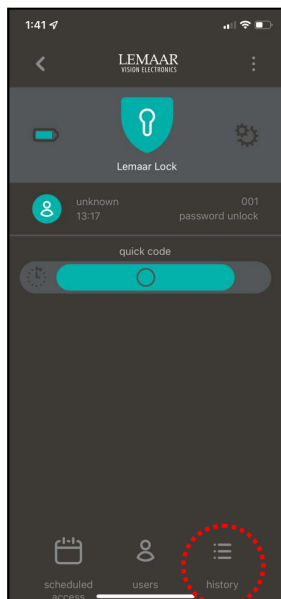

Tap the **History** icon at the bottom right of the device page.

Step 2:

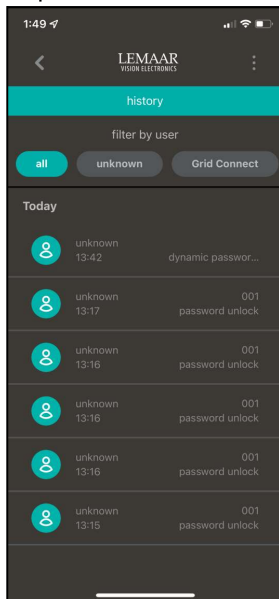

Review all lock entries and events.

Note: Once **Users** have been setup and accounts are linked to user IDs on the lock, their details will appear here

6.5 Other functions

Alert history.

Shows record of alarms tripped at the lock (e.g. hijack alarm). These records are accessible via the settings "gear" icon on the main device page.

Device Settings.

The top right icon (3 vertical dots) will open additional settings and information including device name, device information, automation options, FAQs and remove device.

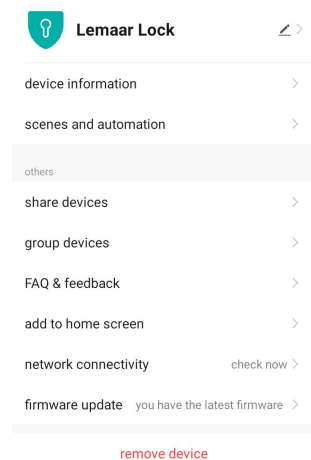

7.2 Troubleshooting (app)

| Problem | Possible Causes | Suggested Remedy |
|--|--|--|
| Cannot pair device to app. | (1) The device hasn't been reset. (2) The device is not in the correct app pairing mode. | (1) Perform a hard reset by pressing and holding the SET button located behind the battery cover for 5 seconds (Note: this will delete all data on the lock and unpair any mobiles). (2) Ensure AP pair mode on the app is selected during pairing procedure as per instructions provided. |
| Cannot connect device to the Wi-Fi network | (1) Incorrect Wi-Fi network SSID selected. (2) Incorrect Wi-Fi password supplied. | (1) Refresh network list in phone Wi-Fi settings until SmartLife-XXXX is shown. Pair as per instructions provided. (2) Ensure the correct password is entered into the app. (3) Ensure your Wi-Fi network can facilitate a 2.4Ghz connection. |
| Lock does not present on app. | (1) Lock has not been paired to the app. (2) Lock has been accidentally deleted from the app. | Lock must be re-paired to app. Perform a hard reset by pressing and holding the SET button located behind the battery cover for 5 seconds. Pair as per the instructions provided. |
| Cannot create quick code/scheduled access password in app. | Incorrect setup of lock in app. | Lock requires at least one new ADMIN set and learnt overriding the default ADMIN settings before quick code/scheduled access passwords can be set. |
| Quick code/scheduled access password does not work when inputted into keypad. | (1) No network connection. (2) Lock has not been synced. (3) Password has expired. (4) Password is not being accessed during set times. | (1) Check in the app to ensure the lock is connected to the network. (2) Press 9# on the lock keypad to sync and force update from the cloud. (3) Program valid password (4) Double-check access times set. |
| Remote unlock via app does not work after initiating request from the lock. | (1) No network connection. (2) Lock has not been synced. | (1) Check in the app to ensure the lock is connected to the network. (2) Press 9# on the lock keypad to sync and force update from the cloud. |
| Not receiving notifications. | (1) No network connection. (2) Phone/device notification settings. | (1) Check in the app to ensure the lock is connected to the network and the phone has data coverage or Wi-Fi network connected. (2) Ensure notifications alerts from the app on your phone/device is enabled. |

7.3 Notes

| | |
|--|--|
| | |
| | |
| | |
| | |
| | |
| | |
| | |
| | |
| | |
| | |
| | |
| | |
| | |
| | |
| | |
| | |
| | |
| | |
| | |
| | |
| | |