



SLIMLINE

HIGH GLOSS PATIO ROOFING

ATTACHED SLIMLINE ROOF for VERANDAH / AWNING / PATIO

Your complete guide to building an
attached verandah, awning or patio

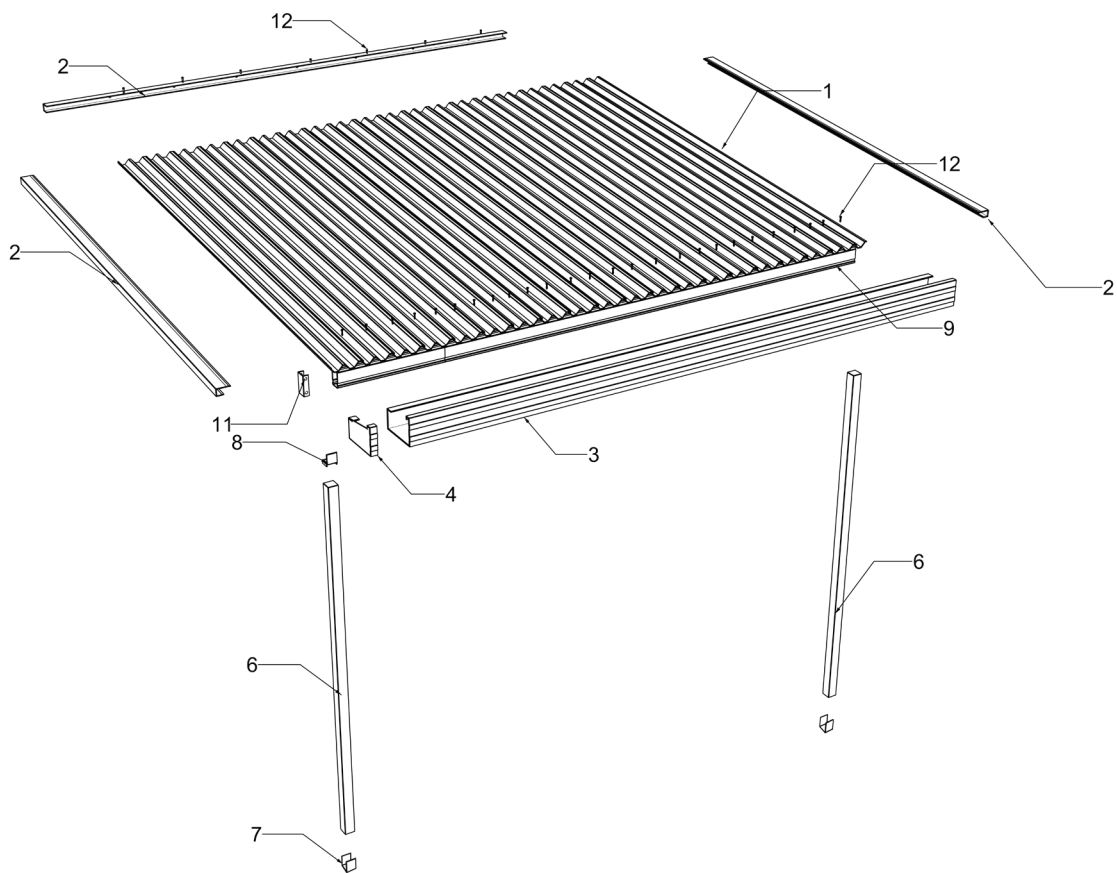

TOOLS REQUIRED

- Drill & Hex-Head Adaptor
- Spanners or Ratchet
- Tape Measure
- Spirit Level
- Silicone Gun
- Neutral-cure silicone
- Ladder
- Hacksaw
- Rivet Gun
- Tin Snips
- Stringline
- Adjustable Construction Props

Distributed by:

ATTACHED ROOF

1.0 LAYOUT OF COMPONENTS FOR A SINGLE ROOF

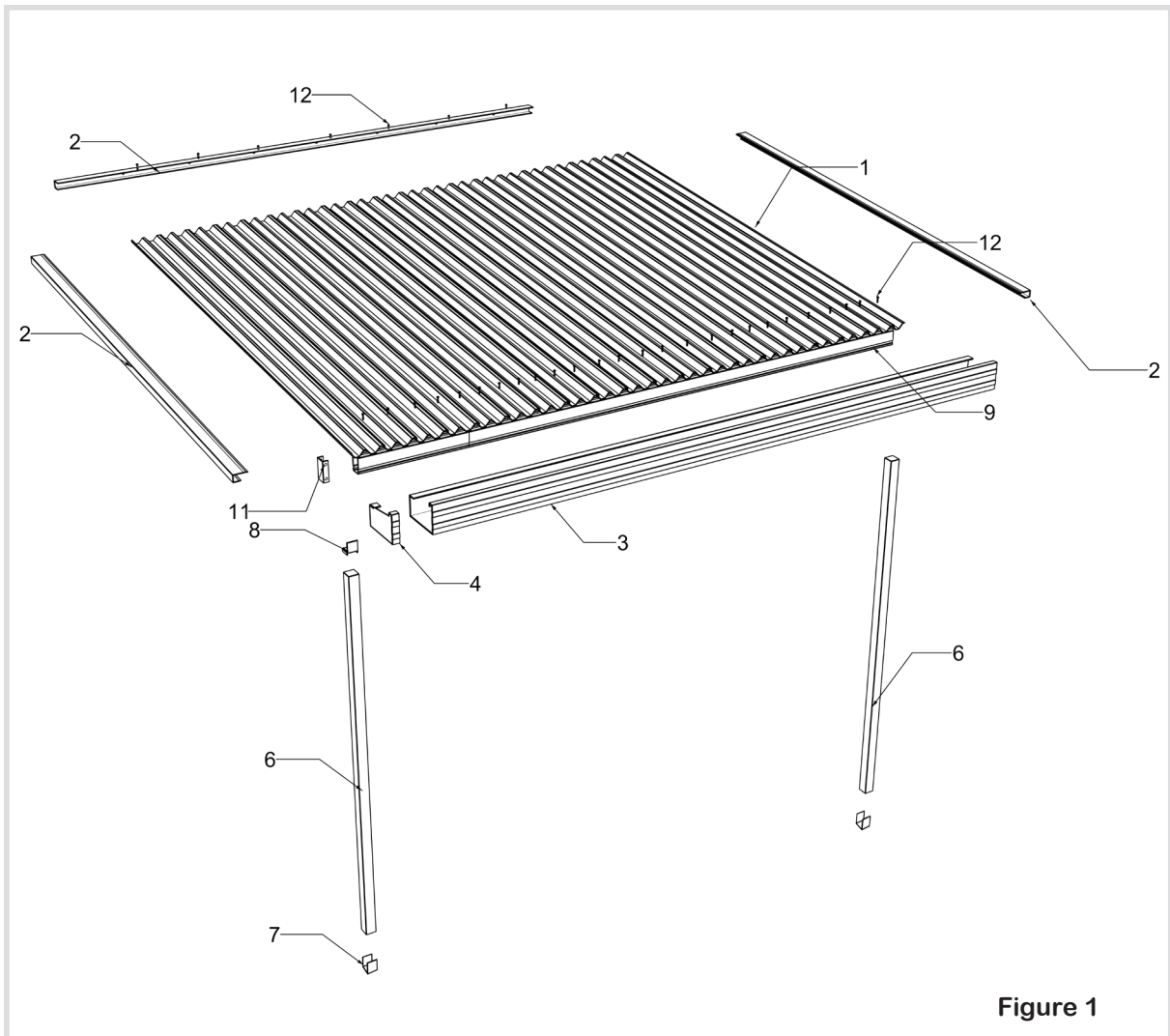

Figure 1

LIST OF SUPPLIED COMPONENTS AND QUANTITIES

Item	Component	Item	Component
1A	Slimline W300 Roofing	9	Beam
1B	Slimline FLAT Roofing	10	Beam Join Connectors
2	Receiver and Side Channel	11	Beam End Caps
3	Gutter	12	Screw SD Hex Neo Class 4 12-14x20
4	Gutter End Caps	13	Rivets A/S 3.2mm Colour
5	Gutter Brackets	14	Wafer Head 10-16 x 16 Class 4 Colour
6	Posts		
7	Post Base		
8	Post / Beam Connectors		

ATTACHED ROOF

2.0 PARTS DESCRIPTION

1A Roof Sheet
Slimline W300

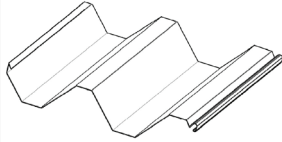

1B Roof Sheet
Slimline FLAT

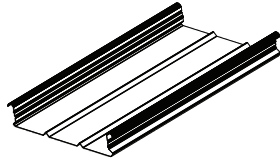

1C Corrosan 762
Roof Sheet



2 Back & Side Channel

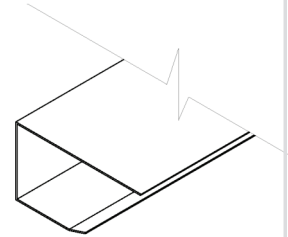

3 Gutter

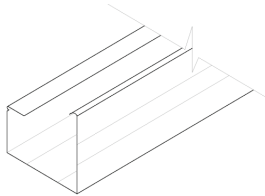

4 Gutter End Caps

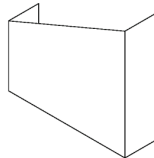

5 Gutter Brackets



6 Posts

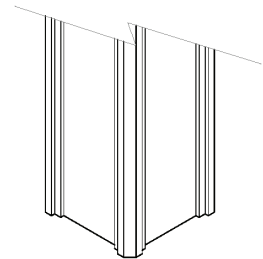

7 Post Base

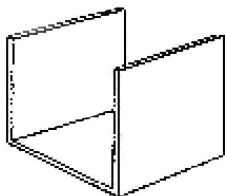

8 Post / Beam
Connectors

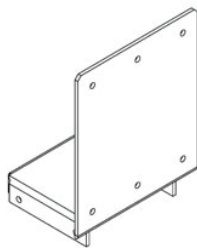

9 Beam

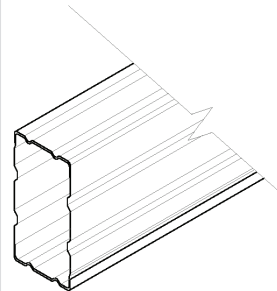

10 Beam Join
Connectors

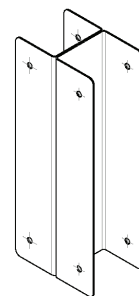

11 Beam End Caps

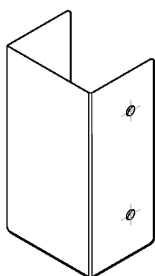

12 Screw SD Hex Neo
Class 4 12-14x20



13 Rivets A/S 3.2mm
Colour

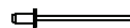

14 Wafer Head 10-16 x
16 Class 4 Colour

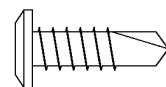

ATTACHED ROOF

3.0 OVERVIEW OF INSTALLATION PROCEDURE FOR ATTACHED ROOF

The attached roof is secured to the building wall and concrete slab as shown in Figure 2

The steps to install the attached roof are generally as follows:

- Install the back channel (item 2) Install both post bases (item 10) onto the concrete slab. If required, cut the posts (item 6) to length.
- On the ground, install the beam end caps (item 11) and connect the beam (item 12) to both posts.
- Lift the assembled beam and posts into position on the post caps and temporarily brace the posts.
- Install side channel (item 2) to one side of the first section of roof sheet (item 1).
- Lift the first section of roof sheet into the back channel and secure.
- Install the second section of roof sheet.
- Continue installing the remaining roof sheets in the same manner.
- Install the side channel (item 2) onto the last section of roof sheet.
- Secure the roof sheets to the beam.
- Install gutter, gutter end caps, and gutter brackets (items 3, 4 & 5).

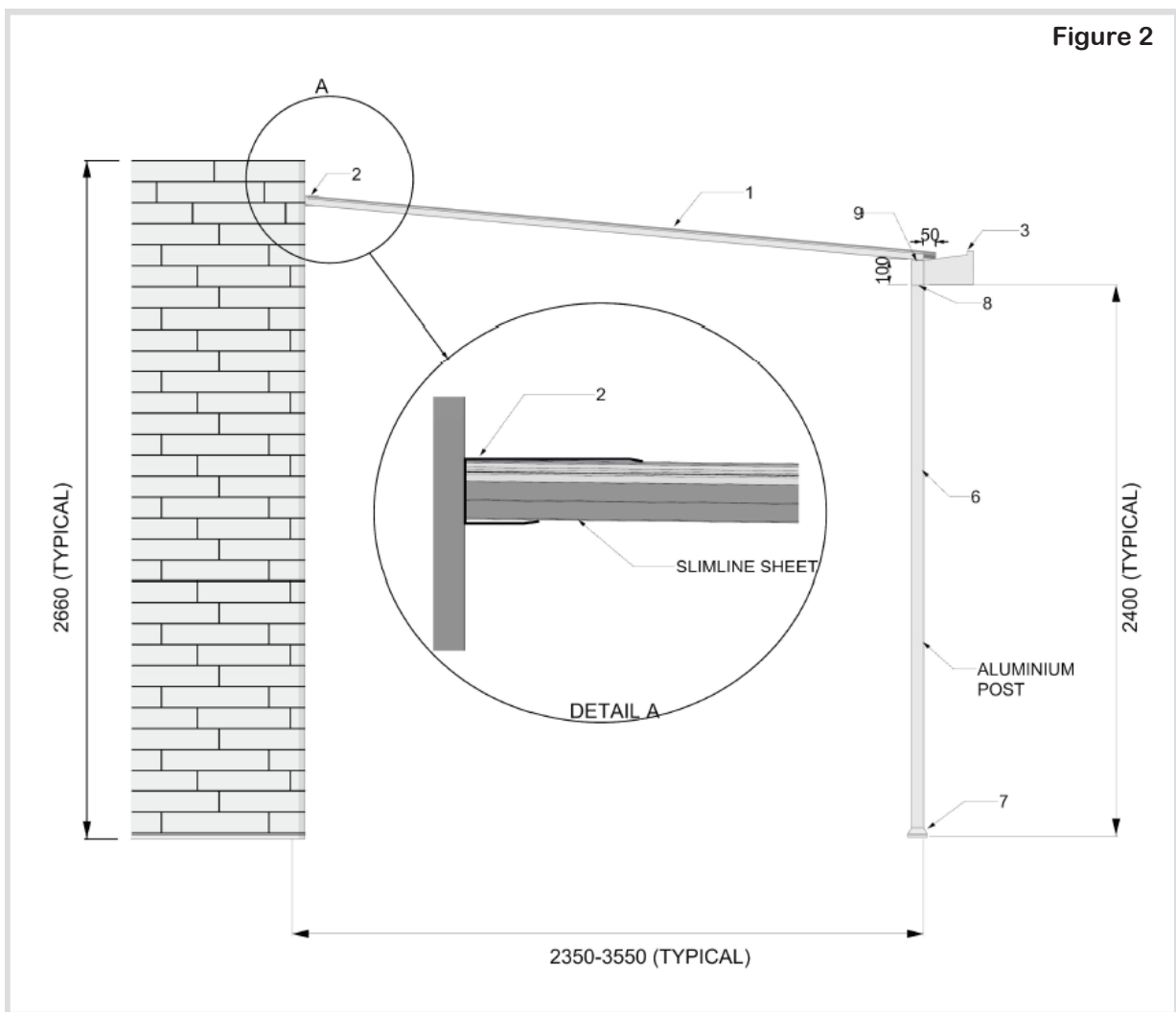

ATTACHED ROOF

4.0 BEFORE YOU START

Please read these instructions carefully before starting any installation.

The parts description on page 2 identifies all the components supplied and shows where each component is located

5.0 LOCAL GOVERNMENT and BUILDER

It is important to check with your Local Government Authority (Council) prior to installation of the attached roof to confirm any building approvals that may be required and to confirm disposal of roof run off water

It is the Builders responsibility to ensure the existing structures are adequate to support the Insulspan attached roof. If required, the Builder must adequately reinforce existing structures to accommodate the additional building loads imposed by the Insulspan attached roof.

6.0 MARKING OUT THE BACK CHANNEL/ATTACHED ROOF LOCATION

Mark out the location of the receiver channel and on the ground, mark out the overall area of the attached roof to ensure the location is free of any obstructions.

Ensure there will be no interference with existing door or window openings in the area where the attached roof will be located against the existing building

6.1 INSTALLATION OF THE BACK CHANNEL

The shorter edge of the back channel should sit on the underside when fixed. If more than one length of back channel is required, butt the two lengths together and waterproof with silicone. Pre-drill the back channel on the ground. Locate the first hole 100mm from the edge on the back face of each length of channel.

Drill the other holes at 400mm centres. When fixing to a steel fascia, the roofing or eave lining must be removed and steel fascia brackets fixed to the side of the house rafters. It is the builder's responsibility to determine the adequacy of the fascia and rafters and the frequency of the brackets for each individual situation.

Deburr any cut ends and remove the swarf. Run a bead of silicone along the rear of the Back channel near the top and lift it into place on the wall or fascia. Ensure that any gaps between the back channel and the fascia or wall are sealed. When fixing the back channel to timber fascia use either 6x38mm coach screws or 12x40mm Type 17 screws. When fixing the receiver channel to brickwork use either M6.5x55mm masonry anchors or 6.5x32mm Tappers. For steel fascias use 10x16mm self-drilling screws and M10x25 hex bolts to fasten the Back channel to the steel fascia brackets.

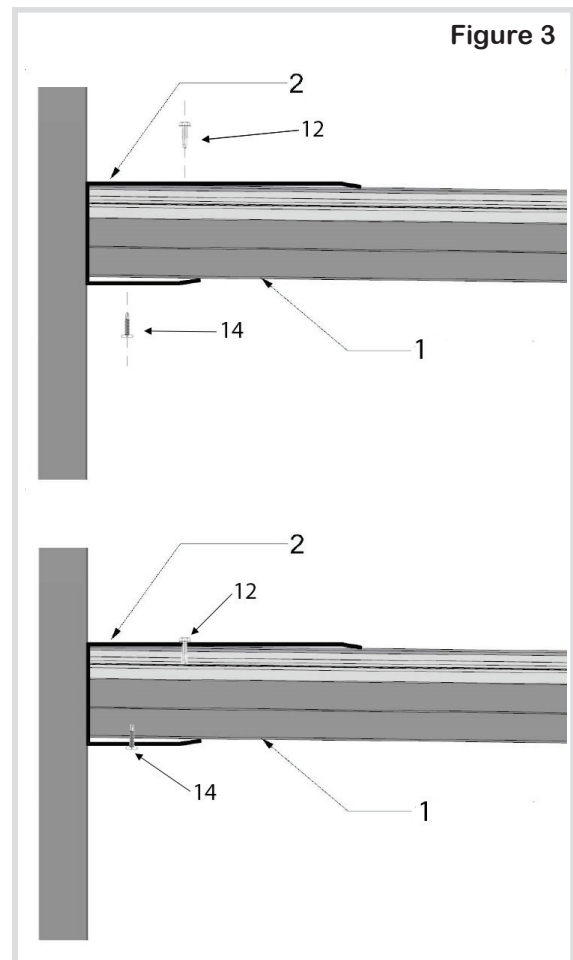

Figure 3

Figure 3 shows the assembly of the wall channel and the attached roof.

7.0 POSTS / BEAM AND CONCRETE SLAB

7.1 FIXING POSTS TO EXISTING CONCRETE SLAB

Before installing the post bases to the concrete slab, ensure the position of the post bases has been correctly measured.

The post bases (item 7) must be installed and bolted to the concrete slab before installing the posts (item 6).

Measure and mark the position of the post bases on the concrete slab.

Drill holes for the dynabolts and bolt the post bases to the slab.

The posts are supplied in standard lengths and are normally cut to a shorter length to accommodate any variation in the slab height or the relative position of the receiver channel.

If required, cut the posts (item 6) to length.

Install the beam end caps (item 11) onto each end of the of the beam (item 9) using wafer head screws (item 13).

Install the post / beam connectors (item 8) into the beam (item 9) at the correct location and secure using wafer head screws (item 13).

Slide the posts (item 6) over the post / beam connectors (item 8) and secure using wafer head screws (item 13).

Lift the assembled beam and posts onto the post bases and temporarily brace the posts in the correct position.

Secure the posts (item 6) to the post bases (item 7) using wafer head screws (item 13).

The posts and back channel are now ready to install the roof sheets.

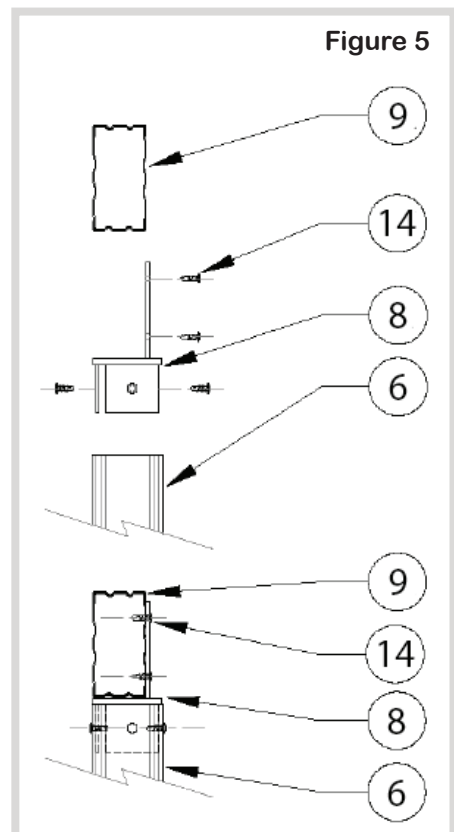
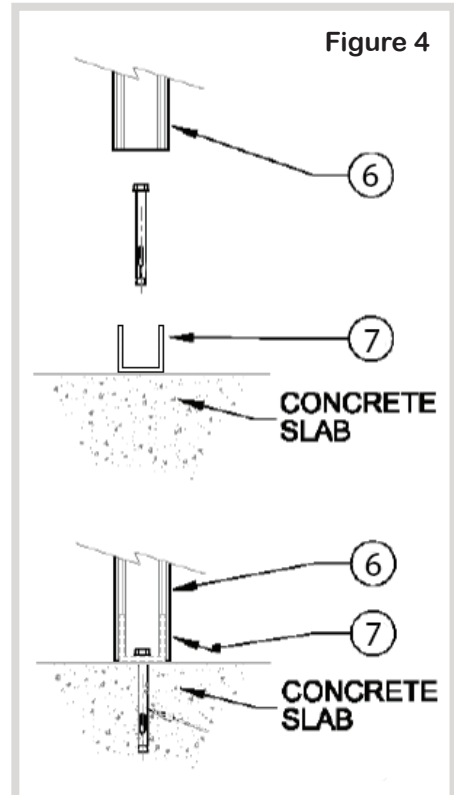

8.0 INSTALLING THE SLIMLINE ROOF SHEETS

Sheeting should be laid with the overlapping rib away from the prevailing wind. Ensure that all of the sheet overlaps are facing the same direction. Mark the back channel and front Alysplan beam every 1000mm to check that the sheeting is laid square.

Begin installing the first sheet of roofing. Lift the first sheet into place and slide it firmly into back channel. Check the sheet is square against the back channel. At the back channel end, fix the sheets from underneath through the raised edge of the bottom of the back channel, using one wafer head screw per pan. Weather proof with silicone. From the top, fasten the roof sheet through the back channel using a 12-14 x 20 Neo Class 4 screw every second rib. At each supporting beam fasten down the sheet from above using one 12-14 x 20 Neo Class 4 self-drilling screw per pan. Remove any swarf. Lay each sheet over the side lap of the previous sheet and slide the sheet firmly into back channel. Fasten as previously described and remove any swarf.

Side Channel

To Install Side Channel, Insert channel (item 2) over the side edge of the first roof sheet that was installed. The Side channel must be inserted over roof sheet but in between the back channel. Fix Side channel to top of roof sheet using 12-14 x 20 Neo Class 4 self-drilling screws at 600 centres. Fix side channel from the bottom into roof sheet using wafer head screws at 600 centres. Repeat for the other side of the patio. Weatherproof with silicone.

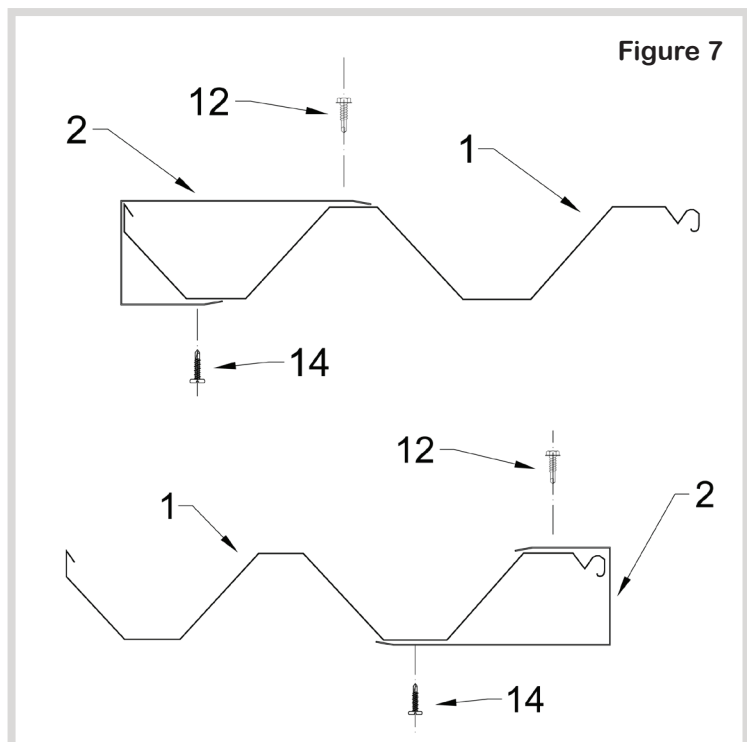
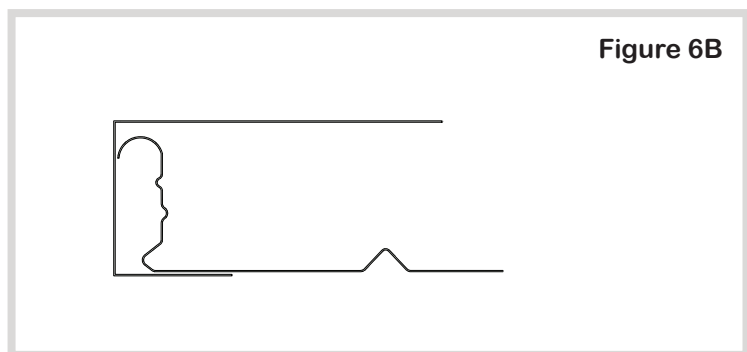
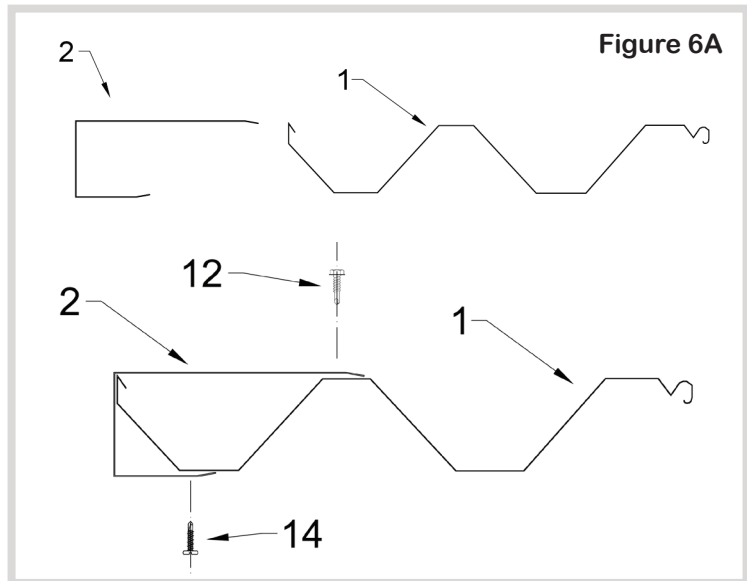

9.0 INSTALLING GUTTER

Preparing the Gutters

The back face of the front gutter should be the same length as the front Alysplan beam. Where more than one length of gutter is needed along a straight run, allow for an additional 100mm at the overlap. Cut the gutters to the correct measurements. Attach the stop ends to the side gutters using 3mm rivets, remove any swarf and weatherproof with silicone. Determine the position of the downpipe (this should be in line with a post) and cut a hole in the base of the gutter. Insert the gutter outlet from the inside of the gutter and rivet the outlet in place using 3mm rivets, remove any swarf and weatherproof with silicone.

Installing the Gutters

Temporarily fix the front gutter to the roof decking using clamps at 300mm centres. Adjust the position of the gutter to ensure that the roof decking overhangs 50mm into the gutter. Screw through the top of the roof sheet and back lip of the gutter at maximum 900mm centres, using 12-14 x 20 Neo Class 4 self-drilling screws. Starting from one end, insert a gutter clip into the higher end of the gutter and lower the flat side of the gutter clip onto the lower pan of the roof sheet. Fix gutter clip using a 12-14 x 20 Neo Class 4 screw through the clip, roof sheet and gutter lip. Repeat every 1000 mm.

Alternate Post Connection

If using 50 x 50 square posts, attach two beam end caps to the adjacent faces of the corner post, with two Wafer head self-drilling screws. If you are fixing the posts into the ground, dig the first hole to the specified size. Place a half brick in the bottom of the hole. Measure from the top of the beam to the top of the half brick and cut the post to this length. Place the bottom of the post on the half brick. Slide the beam end cap at the top of the post, over the end Alysplan beam. Square the post using a spirit level and fix the beam to the beam end cap using wafer head screws. Do not concrete the posts into position at this stage, as this is done after the decking and gutters have been installed and a final check for squareness has been completed.

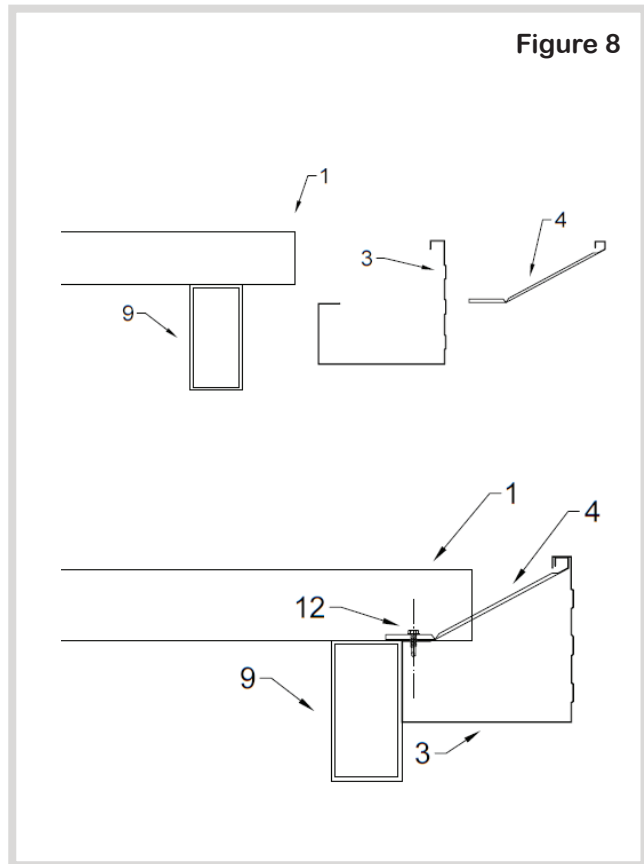

Figure 8

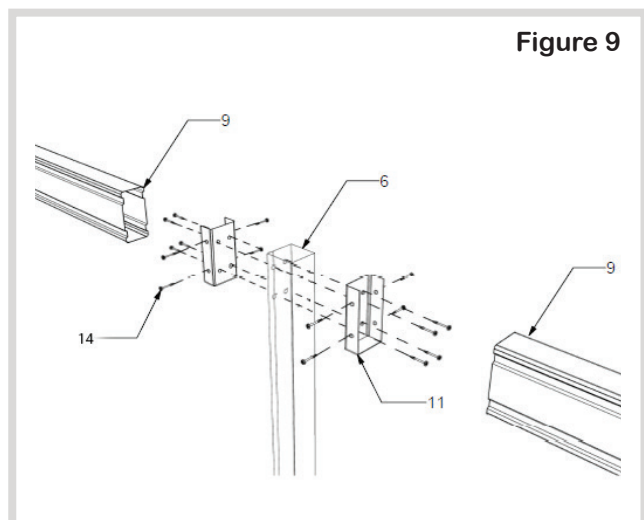

Figure 9