

Designed to Enhance

EST. 1981

omega

Installation + User Manual

OBOS6010AML / OBOS6010AMR

Built-in 10 Function Side-opening Oven 60cm

Contents

03	Welcome
04	Safety Information
07	Your Oven
09	Oven Functions
11	Operating Instructions
13	Cooking Guidelines
15	Installing Your Oven
19	Practical Advice
20	Cleaning & Maintenance
23	Troubleshooting
25	Purchase Details
26	Warranty Information

Welcome

Residentia Group

Office 165 Barkly Avenue Burnley
Victoria Australia 3121

ACN 70 600 546 656

Online residentia.group
omegaappliances.com.au

Post PO BOX 5177 Burnley
Victoria Australia 3121

Phone 1300 11 4357

Email support@residentia.group

Congratulations on purchasing your Oven!

Omega appliances are proudly owned, distributed, designed and engineered in Australia by Residentia Group Pty Ltd.

Please refer to the warranty chapter at the rear of this manual for information regarding your product's parts and labour warranty, or visit us online at:

→ www.residentiagroup.com.au

Here at Residentia Group, we are customer obsessed and our Support Team are there to ensure you get the most out of your appliance. Should you want to learn more about your unit, and importantly, taking care of the appliance, our Support Team are here to help. You can use our online Support Centre at any time by visiting:

→ www.support.residentiagroup.com.au

Or you can contact us by dialling: 1300 11 HELP (4357)

It is important that you read through the following user manual thoroughly, in order to familiarise yourself with the installation and operation requirements of your appliance, and to ensure optimum performance.

Again, thank you for choosing an Omega appliance and we look forward to being of service to you.

Kind Regards,

The Residentia Team

Customer Care

At Residentia Group, we strongly encourage the use of authentic spare parts to guarantee the best results. When contacting our spare parts team through 1300 11 HELP, or by emailing parts@residentiagroup.com.au, please ensure that you have the model and serial numbers on hand, which are found on your appliances' rating plate.

Safety Information

Important Safety Instructions

Read Carefully and Keep for Future Reference

Read this manual thoroughly before first use, even if you are familiar with this type of product. The safety precautions enclosed herein reduce the risk of fire, electric shock and injury when correctly adhered to. Make sure you understand all instructions and warnings.

Keep the manual in a safe place for future reference, along with the completed warranty card and purchase receipt. If you sell or transfer ownership of this product, pass on these instructions to the new owner.

Always follow basic safety precautions and accident prevention measures when using an electrical appliance. The following statements you will see in this booklet have these meanings:

WARNING: Indicating information concerning your personal safety.

CAUTION: Indicating information on how to avoid damaging the appliance or cabinetry.

IMPORTANT: Indicating tips and information about use of the appliance.

Usage Conditions and Restrictions

- Domestic use only: This appliance is intended for indoor household use only. It is not intended for commercial, industrial or outdoor use. It is not intended for use in a recreational vehicle.
- Purpose: Do not use this appliance for anything other than its intended purpose. Other uses are not recommended and may cause fire, electric shock or personal injury.
- Attachments: The use of attachments is not recommended by the appliance manufacturer and distributor as they may be hazardous.
- Improper use: Damage due to improper use, or repairs made by unqualified personnel will void your warranty. We assume no liability for any eventual damages caused by misuse of the product or non-compliance with these instructions.

Before Using Your Appliance

This manual explains the proper use of your new Omega oven. Please read this manual carefully before using the product. This manual should be kept in a safe place for handy reference.

This oven is a domestic appliance which has been manufactured and tested to comply with Australian and New Zealand Standards.

This oven must only be installed in accordance with the instructions provided. Incorrect installation may cause harm to persons, damage property and void the product's warranty.

Read the following carefully to avoid damage or injury.

IMPORTANT: Check for any damage or marks. If you find the appliance is damaged or marked, you must report it within 7 days if you wish to claim for damage/ marks under the manufacturer's warranty. This does not affect your statutory rights.

Safety Instructions

- Before the installation and use of the appliance, carefully read the supplied instructions.
- The manufacturer is not responsible if an incorrect installation and use causes injuries and damages.
- Always keep the instructions with your appliance for future reference.
- Do not use the oven unless you are wearing something on your feet. Do not touch the oven with wet or damp hands or feet.
- Some parts of appliance may keep its heat for a long time; it is required to wait for it to cool down before touching onto the points that are exposed to the heat directly.
- If you will not use the appliance for a long time, it is advised to turn the plug off.

WARNING: To prevent any damages to your and others' life or property, you have to follow the safety notes.

WARNING: Caution, risk of fire!

Safety Information

Children & Vulnerable People Safety

WARNING: Risk of suffocation, injury or permanent disability.

This appliance can be used by children aged from 8 years and above and persons with reduced physical, sensory or mental capabilities or lack of experience and knowledge if they have been given supervision or instruction for the operation of the appliance by a person who is responsible for their safety.

- Do not let children play with the appliance.
- Keep all packaging away from children.
- Keep all detergents away from children.
- Keep children and pets away from the appliance door when it is open.
- Do not allow children to go near the oven when it is operating, especially when the grill is on.
- Cleaning and user maintenance shall not be made by children without supervision.

Before Installation

- Remove all the packaging.
- Do not install or use a damaged appliance.
- Always move the appliance cautiously. Do not use the machine door or the handle of oven, to lift the appliance.
- When the oven is first switched on, it may give off an unpleasant smell. This is due to the bonding agent used for the insulating panels within the oven. Please run the new empty oven with the conventional cooking function, 250°C for 90 minutes to clean oil impurities inside the cavity.
- During the first time use, it is completely normal that the oven will show slight signs of smoke and unpleasant odours. Please wait for the smell to clear before putting food into the oven.
- Please use this product under the open environment.
- The appliance and its accessible parts become hot during use. Care should be taken to avoid touching heating elements.
- If the surface is cracked, switch off the appliance to avoid the possibility of electric shock.
- During use, the appliance becomes very hot. Care should be taken to avoid touching heating elements inside the oven.

- Ensure that the appliance is switched off before replacing the oven lamp to avoid the possibility of electric shock.
- The means for disconnection must be incorporated in the fixed wiring in accordance with the wiring specifications.
- Accessible parts may become hot during use.
- An all-pole disconnection means must be incorporated in the fixed wiring in accordance with the wiring rules.
- The appliance must be installed by an authorised technician and put into use. The manufacturer is not responsible for any damage that might be caused by defective placement, and installation by unauthorised personnel.
- Please contact 1300 11 HELP (4357) to arrange an authorised technician.

Electrical Connection

CAUTION: Risk of fire and electrical shock!

- The appliance must be earthed.
- Make sure that the electrical information on the rating plate agrees with the power supply. If not, contact an electrician.
- Always use a correctly installed shockproof socket.
- Do not use any multi-plug adapters or extension cables.
- Connect the mains plug to the mains socket only at the end of the installation. Make sure that there is access to the mains plug after the installation. Do not connect the appliance plug with a power connection board.
- Do not pull the mains cable to disconnect the appliance. Always pull the mains plug.
- Do not touch the mains cable or the mains plug with wet hands.

WARNING: If the supply cord is damaged, it must be replaced by the manufacturer or its service agent or similarly qualified person in order to avoid a hazard.

WARNING: All electrical work must be done in accordance with local and national electrical codes as applicable and should be undertaken by licenced and qualified persons only. Failure to follow these instructions can result in death, fire or electrical shock.

Safety Information

Appliance Use

WARNING: Risk of fire, explosion, electric shock or damage to the appliance.

- Use this appliance in a household only.
- Do not change the specification of this oven.
- Do not sit or stand on the open door.
- Please do not close the machine door with excessive force
- When the door or drawer of oven is open do not leave anything on it, you may unbalance your appliance or break the door.
- The appliances are not intended to be operated by means of an external timer or separate remote control system.
- The instructions for ovens that have shelves shall include details indicating the correct installations of the shelves.

Care & Cleaning

CAUTION: Risk of injury or damage to the oven.

- Before maintenance, deactivate the appliance and disconnect the mains plug.
- Do not use a steam cleaner on the appliance.
- Clean the appliance with a moist soft cloth. Only use neutral detergents. Do not use abrasive products, abrasive cleaning pads, solvents or metal objects.
- Do not use harsh abrasive cleaners or sharp metal scrapers to clean the oven door glass since they can scratch the surface, which may result in shattering of the glass.

Unpacking

- During transportation, protective packaging was used to protect the appliance against any damage. After unpacking, please dispose of all elements of packaging in a way that will not cause damage to the environment.
- All materials used for packaging the appliance are environmentally friendly; they are 100% recyclable and are marked with the appropriate symbol.

CAUTION: During unpacking, the packaging materials (polythene bags, polystyrene pieces, etc.) should be kept out of reach of children.

Disposal of the Appliance

- Disconnect the appliance from the mains supply.
- Cut off the mains cable and discard it.
- Remove the door catch to prevent children and pets to get closed in the appliance.
- Old appliances should not simply be disposed of with normal household waste and should be delivered to a collection and recycling centre for electric and electronic equipment. A symbol shown on the product, the instruction manual or the packaging shows that it is suitable for recycling.



- The packaging is designed to protect the appliance from damage during transportation. The packaging materials are environmentally friendly and should be recycled. Recycling the packaging can reduce the use of raw materials in the manufacturing process and the amount of waste in landfill sites
- Packaging materials of the product are manufactured from recyclable materials in accordance with our National Environment Regulations. Do not dispose of the packaging materials together with the domestic or other wastes. Take them to the packaging material collection points designated by the local authorities.
- Materials used inside the appliance are recyclable and are labelled with information concerning this. By recycling materials or other parts from used devices you are making a significant contribution to the protection of our environment.
- Information on appropriate disposal centres for used devices can be provided by your local authority.

Declaration of Compliance

When you have unpacked the oven, make sure that it has not been damaged in any way. If you have any doubts at all, do not use it: contact a professionally qualified person. Keep packing materials such as plastic bags, polystyrene, or nails out of the reach of children because these are dangerous to children.

Your Oven

MODEL: OBOS6010AML, OBOS6010AMR

Key

- 1. Control Panel

- 2. Mode Selector Knob

- 3. Touch Control Programmable Timer

- 4. Temperature (°C) Knob

- 5. Door

- 6. Door Handle*

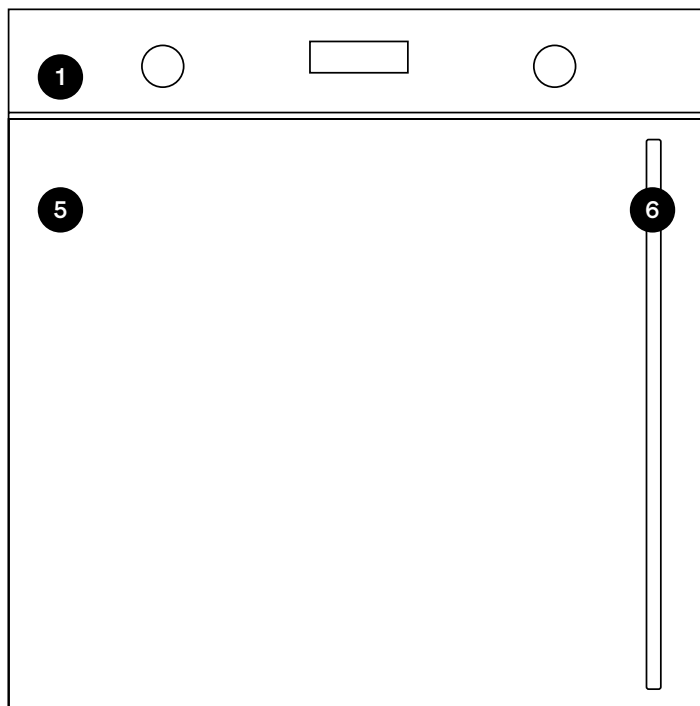

* The Door Handle side will depend on your oven's default configuration.

The Controls

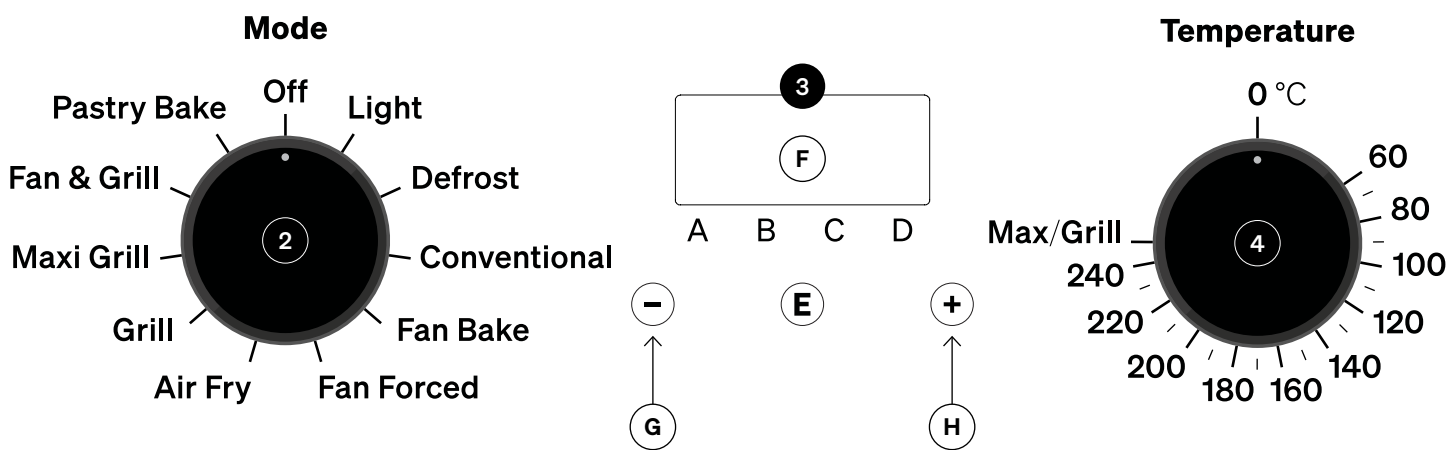

Key

- | | | |
|----------------------|--------------------|----------------------------|
| A. Alarm* | D. Clock* | G. Minus / Decrease Button |
| B. Set Cooking Time* | E. Function Button | H. Plus / Increase Button |
| C. End Cooking Time* | F. LED Screen | |

* Indicators sit above these letters on the LED screen and illuminate when the function is selected.

Note: The diagrams in this user manual are for explanatory purposes only. Your appliance may appear differently.

Your Oven

Parts and Accessories

Your Oven comes with the following accessories:

A. Chrome Wire Shelves (×2)

For roasting and grilling dishes; or for placing trays.

B. Enamelled Baking Tray (×1)

Designed for cooking large quantities of food such as cakes to pastries and frozen foods. It serves as a reliable vessel for collecting fats, spills, and savory juices while ensuring even baking and easy cleanup.

C. Grill Insert (×1)

Place inside the baking tray when grilling.

D. Air Fry Tray (×1)

A specially perforated tray which allows for air circulation for the Air Fry cooking mode. The Air Fry Tray can be placed into side racks in the same manner as the wire shelves.

* User Manual (×1)

* Quick Start Guide (×1)

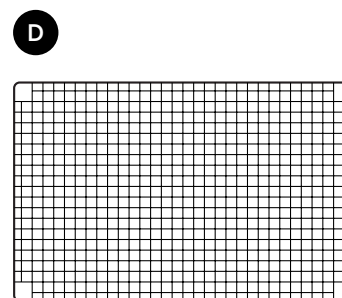
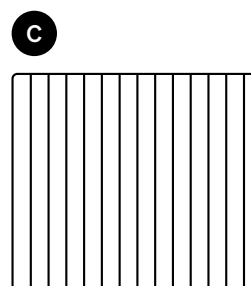
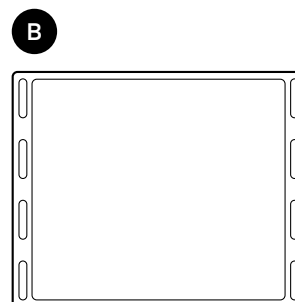
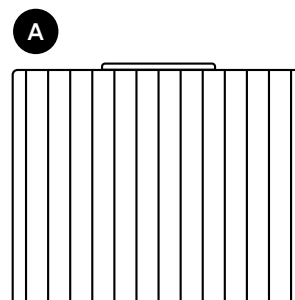

Note: Illustrations are only for reference, your accessories may appear differently.

Shelf Placement

To ensure oven shelves operate safely and effectively, correct placement of between the side rails is critical. Shelves and pans only can be used between the first and fifth levels. Shelves should always be used with the correct placement to ensure that food is cooked evenly and safety, and that during removal hot food items do not slide out.

For most cooking scenarios, we recommend placing the sliding shelves on position 2 and 4.

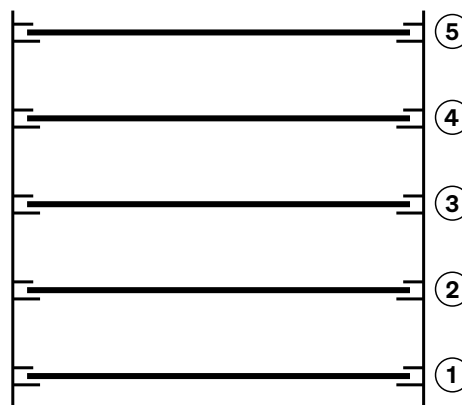

Oven Functions



Light

This feature provides visibility into the oven cavity to monitor your dishes without needing to open the door, ensuring efficient cooking and convenience.

Additionally, the oven light feature aids in maintaining a clean oven by allowing you to easily inspect and clean the oven cavity.

The light will automatically be on when any of the electrical heating elements are in operation.



Defrost

The fan makes the air circulate at room temperature around the food.

This is recommended for the defrosting of all types of food, but in particular for delicate types of food which do not require heat, such as for example: ice cream cakes, cream or custard desserts, fruit cakes. By using the fan, the defrosting time is approximately halved. The thermostat knob can be at any position as no heating element will come on.

Note. The Grill with Fan and Rear Element function can also be used to thaw quickly white or red meat and bread by setting the temperature to 80°C. To thaw more delicate foods, set the thermostat to 60°C or use only the cold air circulation feature by setting the thermostat to 0°C.



Conventional

Temperature Range: 60°C – Max.

On this setting, the top and bottom heating elements come on. This is the classic, traditional type of setting and the conventional function is still unequalled when it comes to cooking dishes with multiple ingredients.

It remains the best system for baking cakes as well as fruit and cooking using covered casserole dishes for oven baking. When cooking in conventional mode, only use one dripping pan or cooking rack at a time, otherwise the heat distribution will be uneven. Using the different rack heights available, you can balance the amount of heat between the top and the bottom of the oven.



Fan Bake

Temperature Range: 30°C – Max.

Fan bake mode activates both the top and bottom heating elements in conjunction with the fan, ensuring even heat distribution throughout the oven.

This mode is particularly suitable for swiftly cooking pre-packaged dishes without the need for preheating.

Examples include frozen or pre-cooked meals. It's also beneficial for certain homemade dishes.

For optimal results, we recommended to use only one specific cooking position (the second from the bottom). Please refer to the "Practical Advice" section for further guidance.



Fan Forced

Temperature Range: 60 – 250°C.

The rear heating element and the fan come on, guaranteeing heat distributed uniformly throughout the oven.

This function is ideal for baking and cooking delicate foods: especially cakes that need to rise and for the preparation of certain dishes on 3 shelves at the same time.



Air Fry

Set the thermostat knob to 230°C.

In the Air Fry oven function, both the top and circular heating elements, along with the fan activate.

In conjunction with the included perforated AirFry tray, this cooking method eliminates the need to flip the food, delivering deliciously crispy results in less time and with minimal oil.

It's perfect for preparing items like nuggets, French fries, chicken wings, fish fingers and similar foods.

Oven Functions



Grill

Temperature Range: 60°C – Max.

The Grill function directs radiant heat from the powerful upper element onto the food.

You can use the this function for tender cuts of meat, steak, chops, sausages, fish, cheese toasties and other quick cooking foods.

When using Grill, always make sure to have the oven door closed. Preheat your grill for 3 minutes to get the best results, this will help seal in the natural juices of steak, chops etc. for a better flavour.

Your grill dish can be slid into either of the 2 spaces within the upper pairs of support rails.



Maxi Grill

Set the thermostat knob to Max.

Both elements on the top come on directing radiant heat from the two powerful upper elements onto the food.

You can use the this function for tender cuts of meat, steak, chops, sausages, fish, cheese toasties and other quick cooking foods.

When using Maxi Grill, always make sure to have the oven door closed. Maxi Grill allows you to take full advantage of the large grill dish area and will cook faster than normal Grill.

For best results it is recommended to preheat your grill for 3 minutes. This will help seal in the natural juices of steak, chops etc. for a better flavour.



Fan & Grill

Temperature Range: 60 – 200°C.

This function offers you the benefits of both Bake and Grill functions. The grill element turns on and off to maintain the set temperature while the fan circulates the heated air. The oven door remains closed for Fan & Grill.

You can use this function for large cuts of meat, giving you a result that is similar to rotisserie cooked meat.

When using this function, it is not necessary to turn the food over during the cooking cycle. Place your food on the 2nd or 3rd oven rack from the bottom and put the grill dish on the lowest shelf position to catch any spills. For best results, set the temperature to 200°C.



Pastry Bake

Temperature Range: 60 – 250°C.

The bottom heating element and the fan come on. This function is suitable for pizza, pastries, cakes and non-dry sweets in baking tins or moulds. Excellent results are also obtained in cooking requiring above all heat from the bottom.

For best results, you are advised to put the pan on a low shelf level.

Operating Instructions

First Use

IMPORTANT: The first time you use your appliance, we recommend you set the thermostat to the highest setting with the Fan Forced function selected and leave the oven on for half an hour with nothing in it and the oven door shut. Then, turn off the oven and open the oven door and let the room air in. The odour that is often detected during this initial use is due to the evaporation of substances used to protect the oven during storage and until it is installed.

NOTE: Place the dripping pan provided on the bottom shelf of the oven to prevent any sauce and/or grease from dripping onto the bottom of the oven only when grilling food. For all other types of cooking, never use the bottom shelf and never place anything on the bottom of the oven when it is in operation because this could damage the enamel. Place your cookware (dishes, aluminum foil, etc.) on the shelves or grill insert provided with the appliance.

Ventilation

When cooking is finished, or in a paused or standby state, and if the oven cavity temperature is over 75°C, the cooling fan will operate for 15 minutes, or alternatively until the oven cavity temperature becomes lower than 75°C.

Using Your Oven

This oven has a digital display with a 24 hour clock and 3 control buttons. When the power is connected, the LED screen displays '12:00' while the illuminated bar on an LED screen above the clock symbol (**D**) flashes.

Setting the time when power is first connected

To set the correct time, press the Plus (+) or Minus (-) button to advance forward or backward until the correct time is displayed. Don't touch a button for 5 seconds and the time will be locked in.

Adjusting the time

Press the Function button (**E**) repeatedly until an illuminated bar on the LED screen above the clock symbol (**D**) flashes, then press the Plus (+) or Minus (-) button to set the time. Don't touch a button for 5 seconds and the time will be locked in.

Manual operation setting

When the power is first connected, the oven will automatically be in manual operation as soon as the time is set. Manual operation will only be overridden if the power to the oven is switched off or if an automatic cooking time is selected (by pressing the function button) and an illuminated bar on the LED screen above Set the Cooking Time (**B**) or End Cooking Time (**C**) is flashing.

Automatic setting

This setting allows you to Set the Cooking Time (**B**), End Cooking Time (**C**), temperature (using the temperature knob) and the cooking function (using the Mode Selector knob). The oven will turn on and start cooking according to the selected cooking function/temperature and then switch off automatically at your desired end time or after the duration you have set.

1. Press the Function button (**E**) repeatedly until an illuminated bar on the LED screen above Set the Cooking Time (**B**) flashes, then press Plus (+) or Minus (-) button to set the time frame for cooking.
2. Press the Function button (**E**) repeatedly until an illuminated bar on the LED screen above End Cooking Time (**C**) flashes and then press the Plus (+) or Minus (-) button to set the time to switch off.
3. To select your desired cooking temperature and cooking function, turn temperature and function knobs.
4. Next, the illuminated bars on the LED screen above the respective icons will flash, indicating that the automatic cooking feature of the oven is set.

For example: if cooking time takes 50 minutes and you want it to finish at 18:00:

1. Press the Function button (**E**) repeatedly until an illuminated bar on the LED screen above Set the Cooking Time (**B**) flashes and set the cooking time 50 minutes.
2. Press the Function button (**E**) repeatedly until an illuminated bar on the LED screen above End Cooking Time (**C**) flashes and set the finish time to 18:00.
3. Next, the current time will be displayed and the illuminated bars on the screen above will flash indicating that the automatic cooking feature is set. When the clock displays 17:10, the oven will start cooking automatically. While cooking the relative bar in the screen will flash.
4. When the clock displays 18:00, the oven will automatically turn off. The alarm will sound and the illuminated bar on the screen will flash. Press any button to stop the alarm.

Semi-automatic setting

There are two methods of semi-automatic cooking:

1. Start cooking now & set cooking time

This setting allows you to start cooking immediately, set the cooking time (up to 10 hours) as well as the temperature and cooking function. The oven will cook according to the selected cooking function & temperature and then switch off automatically once the cooking time has elapsed.

1. Press the Function button (**E**) repeatedly until an illuminated bar on the LED screen above Set the Cooking Time (**B**) flashes, then press the Plus (+) or Minus (-) button to set the time frame for cooking.
2. Set the cooking temperature and function by turning the temperature and function knobs.

The oven will start immediately, the illuminated bar on the screen above Set the Cooking Time (**B**) will flash. After the cooking time has elapsed, the oven automatically turns off. The alarm will sound and the illuminated bar on the screen will flash. Press any button to stop the alarm.

2. Start cooking now and set the finish time:

1. Press the Function button (**E**) repeatedly until an illuminated bar on the LED screen above End Cooking Time (**C**) flashes, then press Plus (+) or Minus (-) button to set the time to finish cooking (up to 23 hours and 59 minutes)
2. Set the cooking temperature and function by turning the temperature and function knobs.

The oven will start immediately, the illuminated bar on the screen above End Cooking Time (**C**) will flash. When the finish time has been reached, the oven automatically turns off. The alarm will sound and the illuminated bar on the screen will flash. Press any button to stop the alarm.

If any button is pressed during semi-automatic cooking, the set cooking time will be displayed on screen. If the finish time is set to the current time, the semi-automatic setting will be cancelled.

Timer





The screen on this oven has a digital countdown timer which can be set up to a maximum of 23 hours and 59 minutes.

To set the timer, press the Function button (**E**) repeatedly until an illuminated bar on the LED screen above Alarm (**A**) flashes. Then press Plus (+) or Minus (-) button to set the countdown timer. After 5 seconds, the time will be set and begin to count down. When the set time is reached the illuminated bar above Alarm (**A**) disappears and the alarm will sound. Press any button to stop the alarm.

Note: After pressing the function button, you have 5 seconds to enter any timer settings or it will automatically cancel.

If there is a power failure, all settings (including the time display) will be lost. At this point, the time and any settings will need to be reset.





Cooking Guidelines

Function	Food	Weight (kg)	Shelf Spot*	Pre-heat (min.)	Temperature	Cook Time (min.)
 Conventional	Duck	1	3	15	200	65-75
	Roast veal or beef	1	3	15	200	70-75
	Pork roast	1	3	15	200	70-80
	Biscuits (short pastry)	-	3	15	180	15-20
	Tarts	1	3	15	180	30-35
 Fan Bake	Frozen Pizza	0.3	2	-	250	12
	Frozen Pies	0.5	2	-	200	20-35
	Frozen Turnovers	0.3	2	-	200	25
	Frozen Lasagne	0.5	2	-	200	35
	Frozen Spring Rolls	0.4	2	-	180	25-30
	Frozen Chicken morsels	0.4	2	-	220	15-20
	Pre-cooked chicken wings	0.4	2	-	200	20-25
	Biscuits (short pastry)	0.3	2	-	200	15-18
	Fruitcake	0.6	2	-	180	45
	Cheese puffs	0.2	2	-	210	10-12
 Fan Forced	Tarts	0.5	3	15	180	20-30
	Fruit cakes	1	2/3	15	180	40-45
	Fruitcake	0.7	3	15	180	40-50
	Sponge cake	0.5	3	15	160	25-30
	Filled pancakes	1.2	2-4	15	200	30-35
	Small cakes	0.6	2-4	15	190	20-25
	Cheese puffs	0.4	2-4	15	210	15-20
	Cream puffs	0.7	1-3-5	15	180	20-25
	Biscuits	0.7	1-3-5	15	180	20-25
	Meringues	0.5	1-3-5	15	90	180
 Pastry Bake	Pizza	0.5	3	15	220	15-20

Note: Cooking times are approximate and may vary according to personal taste. When cooking using the grill or fan assisted grill, the dripping pan must always be placed on the 1st oven rack from the bottom.

* From bottom.

Cooking Guidelines

Function	Food	Weight (kg)	Shelf Spot*	Pre-heat (min.)	Temperature	Cook Time (min.)
 Air Fry	Seared Scotch fillet steak	1	3	5	220	8
	Frozen chips	1	3	5	220	15
	Dry rubbed Chicken drumettes or wingettes	1	3	5	230	15
	Crumbed barramundi fillet	1	3	5	230	15
	Wedge-cut potatoes	0.5	3	5	230	14
	Frozen items (nuggets, crumbed fish etc)	1	3	5	230	15
	Smashed chats, parboiled	1.	3	5	220	15
 Grill	Flat-fish (flounder)	1	4	5	Max	8–10
	Prawn kebabs	1	4	5	Max	6–8
	Fillet of thin white-fish	1	4	5	Max	10
	Grilled vegetables	1	3/4	5	Max	10–15
	Veal steak	1	4	5	Max	15–20
	Cutlets	1	4	5	Max	15–20
	Hamburgers	1	4	5	Max	7–10
	Mackerels	1	4	5	Max	15–20
Toasted sandwiches	-	4	5	Max	2–3	
 Maxi Grill	Flat-fish (flounder)	1	4	5	Max	8–10
	Squid and prawn kebabs	1	4	5	Max	6–8
	Fillet of thin white-fish	1	4	5	Max	10
	Grilled vegetables	1	3/4	5	Max	10–15
	Veal steak	1	4	5	Max	15–20
	Cutlets	1	4	5	Max	15–20
	Hamburgers	1	4	5	Max	7–10
	Mackerels	1	4	5	Max	15–20
Toasted sandwiches	-	4	5	Max	2–3	
 Fan & Grill	Grilled chicken	1.5	3	5	200	55–60
	Calamari	1.5	3	5	200	30–35

Note: Cooking times are approximate and may vary according to personal taste. When cooking using the grill or fan assisted grill, the dripping pan must always be placed on the 1st oven rack from the bottom.

* From bottom.

Installing Your Oven

Before Installation

Ensure that:

- The oven cavity is level and completely square based on the required dimensions
- The installation will comply with all clearance requirements, ventilation requirements and applicable standards and regulations
- The isolating switch will be easily accessible to the customer with the oven installed
- The electrician installing the appliance provides sufficient free length of power supply cable to reach from the bottom rear of the cavity to at least 1.5m in front of the bottom edge of the opening
- The cable may enter the cavity from the side, top or bottom, but top entry must be at the rear of the cavity
- The oven power outlet/connection socket is located outside the cavity if the oven cavity sits close to the rear wall
- The oven will rest on a surface that can support its weight
- The height of the oven cavity from the floor suits the customer
- You consult local building authorities and by-laws if in doubt regarding installation

IMPORTANT! Some environmental factors and cooking habits can cause condensation in and around the oven during use. To protect surrounding cabinetry from possible damage caused by frequent or excessive condensation, we recommend moisture-proofing the oven cavity.

After Installation

Ensure that:

- The oven door can open fully without making contact with the cabinet sides, doors/panels or other obstruction; i.e. ensuring adequate clearances
- The oven is not sealed into the cabinetry with silicone or glue. This makes future servicing difficult. Residentia Group will not cover the costs of removing the oven, or of damage caused by this removal
- The power supply cable does not touch any hot metal parts
- The isolating switch is easily accessible to the customer with the oven installed
- Ensure that all packaging elements have been removed from within the oven before operation

Installing Your Oven

Fitting the Oven Into the Kitchen Unit

- Fit the oven into the space provided in the kitchen unit; it may be fitted underneath a work top or into an upright cupboard. Fix the oven in position by screwing into place, using the two fixing holes in the frame. To locate the fixing holes, open the oven door and look inside. To allow adequate ventilation, the measurements and distances adhered to when fixing the oven.
- **IMPORTANT:** If the oven is to work properly, the kitchen housing must be suitable. The panels of the kitchen unit that are next to the oven must be made of a heat resistant material. Ensure that the glues of units that are made of veneered wood can withstand temperatures of at least 120°C. Plastics or glues that cannot withstand such temperatures will melt and deform the unit.
- Once the oven has been lodged inside the unit, electrical parts must be completely insulated; this is a legal safety requirement. All guards must be firmly fixed into place so that it is impossible to remove them without using special tools. Remove the back of the kitchen unit to ensure that an adequate current of air can circulate around the oven.
- The panels of the adjacent cabinets must be made of heat-resistant material. In particular, cabinets with a veneer exterior must be assembled with glues which can withstand temperatures of up to 100°C.

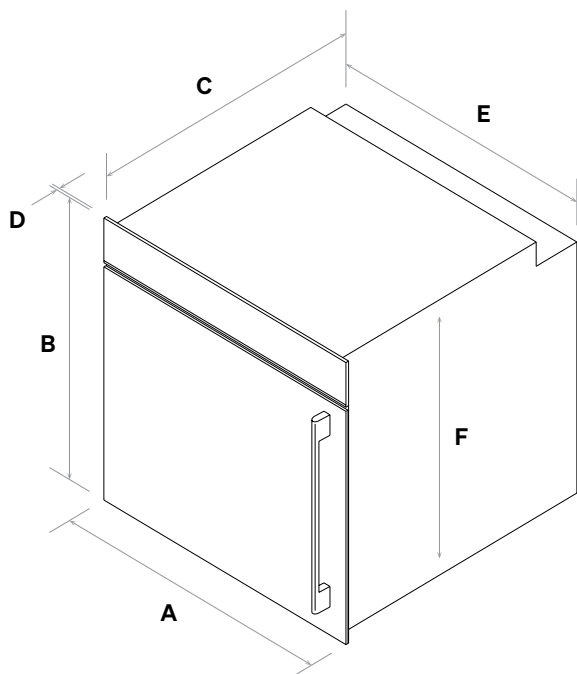

Dimensions (mm)

A	594	D	26.5
B	594	E	565
C	543	F	567.5

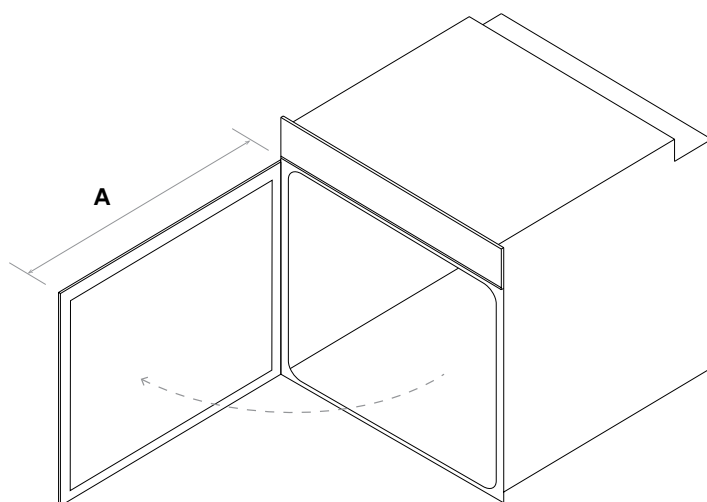

Dimensions (mm)

A	594
---	-----

Installing Your Oven

Installation of Built-in Ovens

In order to ensure that the built-in appliance functions properly, the cabinet containing it must be appropriate. Figure 1 below gives the dimensions of the cut-out for installation under the counter, while Figure 2 shows the dimensions needed for a wall cabinet unit.

- In order to ensure adequate ventilation, the back panel of the cabinet unit must be removed. Installing the oven so that it rests on two strips of wood is preferable. If the oven rests on a continuous, flat surface, there must be an aperture of at least 45×560mm at the rear.
- To fasten the oven to the cabinet, open the door of the oven and attach it by inserting the 4 wooden screws into the 4 holes located on the perimeter of the frame.

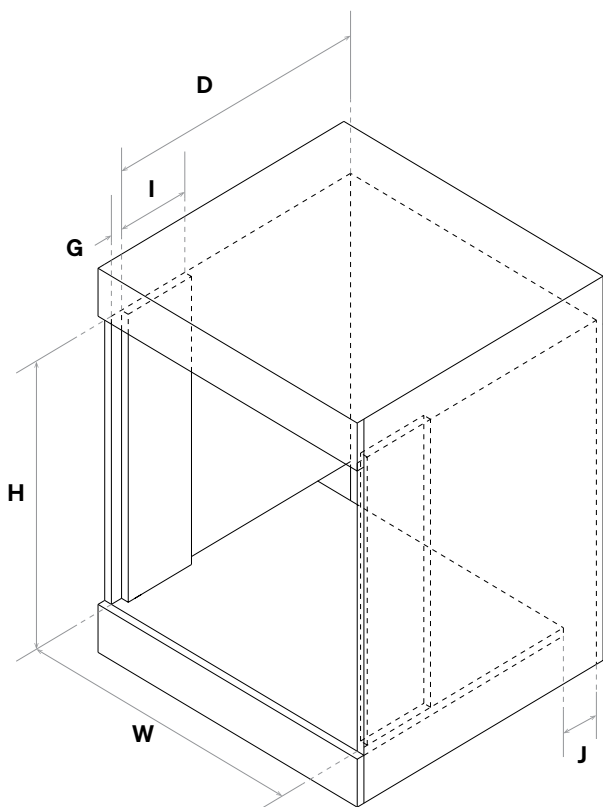

Minimum inside cavity (mm) Fig. 1

W Proud: 568	W Flush: 595
D Proud: 543	D Flush: 569.5
H 595	G 27
I 200	J 45

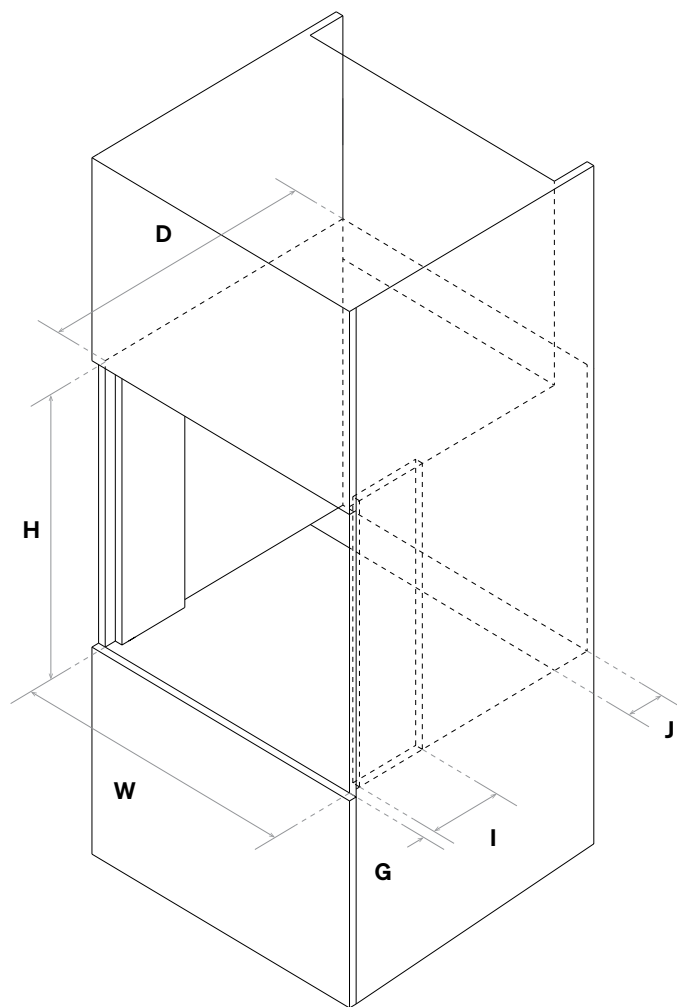

Minimum inside cavity (mm) Fig. 2

W Proud: 568	W Flush: 595
D Proud: 543	D Flush: 569.5
H 595	G 27
I 200	J 45

Installing Your Oven

Electrical Connection

All electrical connections must be made by a suitably qualified and licensed person in accordance with local regulations. Residentia Group will not be held responsible for damages caused to cabinetry due to incorrect installation.

Those ovens equipped with a three-pole power supply cable are designed to operate with an alternating current. The wire for earthing the appliance is yellow-green in colour.

Fitting on a Power Supply Cable

Opening the terminal board:

- Using a screwdriver, prize the bolt on the side tabs of the terminal board cover;
- Unscrew the bolt, pull open the cover of the terminal board.

To install the cable, proceed as follows:

- Remove the wire clamp screw and the three contact screws **L-N-**
- Fasten the wires beneath the screw heads using the following colour scheme: **Blue (N) Brown (L) Yellow-Green**
- Fasten the supply cable in place with the clamp and close the cover of the terminal board.

Connecting the supply cable to the mains

- Install a standardized plug corresponding to the load indicated on the data plate. When connecting the cable directly to the mains, install an omni polar circuit breaker with a minimum contact opening of 3mm between the appliance and the mains. The omni polar circuit breaker should be sized according to the load and should comply with current regulations (the earth wire should not be interrupted by the circuit breaker).
- The supply cable should be positioned so that it does not reach a temperature of more than 50°C with respect to the room temperature, anywhere along its length, or protected by insulation sleeping having an appropriate rating.

Before making the connection, check that:

- The electrical safety of this appliance can only be guaranteed if the cooker is correctly and efficiently earthed, in compliance with regulations on electrical safety. Always ensure that the earthing is efficient; if you have any doubts call in a qualified technician to check the system. The manufacturer declines all responsibility for damage resulting from a system which has not been earthed.
- Before plugging the appliance into the mains, check that the specifications indicated on the data plate (on the appliance and /or packaging)correspond to those of the electrical mains system of your home.
- Check that the electrical capacity of the system and sockets will support the maximum power of the appliance, as indicated on the data plate. If you have any doubts, call in a qualified technician.
- If the socket and appliance plug are not compatible, have the socket replaced with a suitable model by a qualified technician. The latter, in particular, will also have to ensure that the cross section of the socket cables are suitable for the power absorbed by the appliance. The use of adapters, multiple sockets and/ or extensions, is not recommended. If their use cannot be avoided, remember to use only single or multiple adapters and extensions which comply with current safety regulations. In these cases, never exceed the maximum current capacity indicated on the single adapter or extension and the maximum power indicated on the multiple adapter. The plug and socket must be easily accessible.

Voltage and Frequency of Power Supply:

220-240V ~50/60Hz or 50Hz

Practical Advice

The oven offers a wide range of alternatives which allow you to cook any type of food in the best possible way. With time you will learn to make the best use of this versatile cooking appliance and the following directions are only a guideline which may be varied according to your own personal experience.

Preheating

If the oven must be preheated (this is generally the case when cooking leavened foods), the Grill with Fan and Rear Element mode can be used to reach the desired temperature as quickly as possible in order to save on energy.

Once the food has been placed in the oven, the most appropriate cooking mode can then be selected.

Cooking on More Than One Rack

If you have to cook food using several racks, use either the Fan Forced or the Grill with Fan and Rear Element modes, as these are the only modes that allow you to do so.

When cooking delicate food on more than one rack, use the Fan Forced mode, which allows you to cook on 3 racks at the same time: the 1st, 3rd and 5th from the bottom.

When cooking other food on several racks, use the Grill with Fan and Rear Element mode keeping the following suggestions in mind:

- The oven is fitted with 5 racks. During fan assisted cooking, use two of the three central racks; the lowest and highest racks receive the hot air directly and therefore delicate foodstuffs could be burnt on these racks.
- As a general rule, use the 2nd and 4th rack from the bottom, placing the items that require greater heat on the 2nd rack from the bottom. For example, when cooking meat roasts together with other food, place the roast on the 2nd rack from the bottom and the more delicate food on the 4th rack from the bottom.
- When cooking items that require differing times and temperatures, set a temperature that is somewhere between the two temperatures required and place the more delicate food on the 4th rack from the bottom. Lastly, take the food requiring less time out of the oven first.
- Use the dripping pan on the lower rack and the wire shelf on the upper.

Baking Cakes

When baking cakes, always place them in a preheated oven. Make sure you wait until the oven has been preheated thoroughly. Do not open the oven door during baking to prevent the cake from dropping. Some general rules and tips are as follows:

- **Pastry is too dry**
Increase the temperature by 10°C and reduce the cooking time.
- **Pastry dropped**
Use less liquid or lower the temperature by 10°C.
- **Pastry is too dark on top**
Place it on a lower rack, lower the temperature, and increase the cooking time.
- **Cooked well on the inside but sticky on the outside**
Use less liquid, lower the temperature, and increase the cooking time.
- **The Pastry sticks to the pan**
Grease the pan well and sprinkle it with a dusting of flour or use greaseproof paper.

Cooking Fish and Meat

When cooking white meat, fowl and fish, use temperature setting from 180–200°C.

For red meat that should be well done on the outside while tender and juicy in the inside, it is best to start with a high temperature setting (200–220°C) for a short time, then turn the oven down afterwards.

In general, the larger the roast, the lower the temperature setting. Place the meat on the centre of the grid and place the dripping pan beneath it to catch the fat. Make sure that the wire shelf is inserted so that it is in the centre of the oven. If you would like to increase the amount of heat from below, use the low rack heights.

Cleaning & Maintenance

Prior to Cleaning Your Oven

- Before any maintenance and cleaning, turn off the appliance and disconnect the power.
- Set all controls in their off positions: **OFF** or **0**
- Wait until the inside of the unit is not hot but only slightly warm—cleaning is easier than when warm.
- Clean the surface of the unit with a damp cloth, soft brush or fine sponge and then wipe dry.
- In case of heavy soiling, use hot water with non-abrasive cleaning product.
- For cleaning the oven door glass, do not use abrasive cleaners or sharp metal scrapers, as these can scratch the surface or lead to the glass being damaged.
- Never leave acidic substances (lemon juice, vinegar) on stainless steel parts.
- Do not use a high pressure cleaner for cleaning the unit.
- The baking tray and wire shelving may be washed in mild detergent. Alternatively, you can place them in a dishwasher and run a program that does not exceed 30°C
- You can wash the baking tray and wire shelving with mild detergent. Alternatively, you can place them in a dishwasher and run a program that that does not exceed 30°C.

NOTE: If cleaning in a dishwasher, it is not advisable to use rinse aids.

To extend the life of your oven, it must be cleaned frequently, keeping in mind that:

- The enamelled, steel or aluminium parts should be washed with lukewarm water without using any abrasive powders or corrosive substances which could ruin them; stainless steel could get stained. If these stains are difficult to remove, use special products available on the market. After cleaning, it is advisable to rinse thoroughly and dry.
- The inside of the oven should preferably be cleaned immediately after use, when it is still warm, with hot water and soap; The soap should be rinsed away and the interior dried thoroughly. Avoid using abrasive detergents (for example cleaning powders, etc.) and abrasive sponges for dishes or acids (such as lime scale remover) as these could damage the enamel. If the grease spots and dirt are particularly tough to remove, use a special product for oven cleaning, following the instructions provided on the packet. Never use a steam cleaner for cleaning inside of oven.

- If you use your oven for an extended period of time, condensation may form. Dry it using a soft cloth.
- There is a rubber seal surrounding the oven opening which guarantees its perfect functioning. Check the condition of this seal on a regular basis. If necessary, clean it and avoid using abrasive products or objects to do so. Should it become damaged, please contact your nearest After-sales Service Center. We recommend you avoid using the oven until it has been repaired.
- Never line the oven bottom with aluminum foil, as the consequent accumulation of heat could compromise the cooking and even damage the enamel.
- Clean the glass door using non-abrasive products or sponges and dry it with a soft cloth.

Bulb Replacement

To replace your oven cavity's lamp bulb, follow this guide:

- Disconnect power from the mains outlet or switch off the circuit breaker of the unit's mains outlet.
- Unscrew the glass lamp cover by turning it counter-clockwise (note, it may be stiff) and replace the bulb with a new one of the same type.
- Remove the lamp and replace with a lamp resistant to high temperatures (300°C) with the following characteristics:
 - Voltage: 220-240V
 - Wattage: 25W
 - Type: E 14
- Replace the glass cover and reconnect the oven to the mains power supply.

Cleaning & Maintenance

Removing the Oven Door

For easier installation and cleaning, the oven door can be removed to reduce the oven's weight by approximately 14kg (30 lbs) per door.

Follow the instructions below to safely remove the door.

CAUTION:

- Ensure the oven is cool, and power is turned off before removing the door to prevent electrical shock or burns.
- The oven door is heavy and fragile. Always use both hands to handle it. The front panel is made of glass, so handle carefully to avoid breakage.
- Hold the door by its sides, not the handle, to prevent it from swinging unexpectedly and causing injury or damage.
- Improper handling of the door may lead to personal injury or product damage.
- Ensure the hinge brackets are securely locked in place before removing the door to avoid injury from the hinges snapping closed. Do not force the door open or closed, as this could damage the hinge or cause injury.

Reversing the Door Swing

- Depending on the oven model, the door may open from the right or the left, and the glass panels can be removed for cleaning. Follow these steps:
- Open the oven door fully (see Fig. A).
- Grasp the bottom edge of the inner glass and carefully pull it out (see Fig. B).
- Remove the middle glass panel (see Fig. C).
- To reassemble, follow the steps in reverse order.

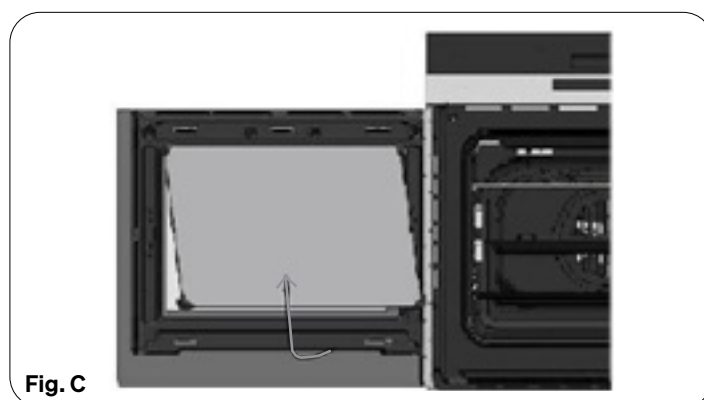
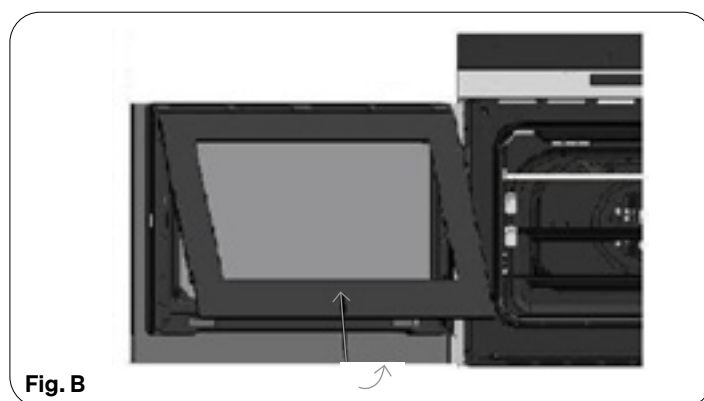
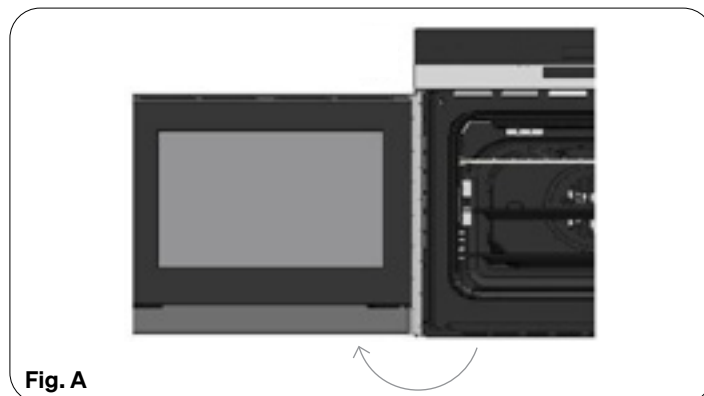

Cleaning & Maintenance

How to Remove the Inner Side Racks

Removing the Inner Side Racks is optional but allows for a more thorough clean. Proceed as follows:

- Carefully push the front of the side racks toward the rear of the oven cavity.
- Pull the front end of the shelf support away from the side wall.
- Pull out the rear of the side rack supports to dislodge them from the cavity mounting holes.

To reinstall the Inner Side Racks:

- Reinsert the rear of the side rack supports into the cavity mounting holes.
- Push the side racks towards the rear of the oven cavity.
- Push the front end back into the side wall.

Steam Refresh

Your oven is designed with a circular cavity well at the base of the oven, making steam-assisted cleaning a relatively simple and effective way to remove grease and grime from your oven cavity.

Before you start, you will need the following:

- A Dishcloth
- Water, 200 ml
- Dishwashing Detergent, 1 tsp
- Scrub brush or sponge (Do not clean using hard tools such as bristle brushes, wire scourers or sharp objects)
- Towel or cloth

NOTE: Fill the cavity well with water only when the oven is cold.

1. Ensure the oven is empty by removing all shelves, trays and side racks.
2. Place a cloth on the base of the oven, mix a teaspoon of detergent into 200ml of water and pour it over the dishcloth into the cavity well.
3. Set the oven to the Conventional function () with a temperature setting of 130°C and run the oven for 24 minutes. The steam created from the water will help loosen any baked-on grime and grease.
4. After 24 minutes, turn off the oven and let it cool down slightly, but not completely. The oven should still be warm, but not hot enough to burn you.
5. Once the oven has cooled to a safe temperature, use a scrub brush or sponge to wipe down the interior surfaces. The steam should have loosened the grime, making it easier to remove. Pay special attention to any stubborn spots.
6. Use a towel or cloth to wipe away any remaining moisture and loosened grime from the oven cavity. Ensure the oven is completely dry before using it again.
7. Once everything is clean and dry, reassemble the oven by reinstalling the side racks and place the any other removable items back into the oven.

Troubleshooting

For Minor Faults

Problem	Possible Cause	Solution
The oven is not turning on.	There may be a break in the power supply.	Check the household fuse box for any blown fuses and replace as necessary. Also ensure that a safety switch hasn't tripped.
The oven light is not working.	The light globe may be loose or, has blown.	When the oven has cooled and is switched off, remove the globe cover and ensure that the globe is tightly secured. If blown, refer to the Cleaning & Maintenance chapter under the Bulb Replacement section.
The oven is burning the top of my dish whilst the underside is under-done.	Not enough heat is emitting from the bottom of the oven cavity.	Try using the Conventional cooking functions. Try lowering the temperature. Try using a lower shelf position.
The oven is burning the underside of my dish whilst the top is under cooked.	Excessive heat is emitting from the bottom of the oven cavity.	Try using the Conventional cooking functions. Try lowering the temperature. Try using a higher shelf position.
The oven is burning the outside of my dish whilst the inside is under-done.	The temperature is set too high.	Lower the oven temperature and increase the cooking duration.
The outside of my dish is too dry even though it looks cooked.	The temperature is set too low.	Increase the oven temperature and decrease the cooking duration.

For Serious Faults

Some minor faults can be fixed by referring to the table above, however if an emergency or serious fault occurs, immediately set all controls to their off positions and disconnect the power from the source.

If a serious fault occurs, DO NOT attempt to repair the oven yourself, instead wait for a service agent to do so.

For assistance or to organise an authorised service agent contact our After Sales Support by calling 1300 11 4357, or by emailing support@residentiagroup.com.au.

Please note that if a service agent is asked to attend whilst the product is under warranty and finds that the problem is not the result of an appliance fault, then you may be liable for the cost of the call out charge.

The appliance must be accessible for the service agent to perform any necessary repair. If your appliance is installed in such a way that a service agent is concerned that damage will be caused to the appliance or your kitchen, then they will not complete a repair.

Please refer to the Warranty Information to learn more.

Purchase Details

For future reference, please record the following information which can be found on the rating plate and the date of purchase which can be found on your sales invoice.

Store Details

Store Name

Address

Telephone

| Purchase Date

Product Details

Model No.

Serial No.

Attach your receipt to this page

Warranty Information

WARRANTY TERMS AND CONDITIONS BUILT-IN OVENS

This document sets out the terms and conditions of the product warranties for Residentia Group Appliances. It is an important document. Please keep it with your proof of purchase documents in a safe place for future reference should you require service for your Appliance.

1. In this warranty
 - (a) 'acceptable quality' as referred to in clause 10 of this warranty has the same meaning referred to in the ACL;
 - (b) 'ACL' means Trade Practices Amendment (Australian Consumer Law) Act (No.2) 2010;
 - (c) 'Appliance' means any Residentia Group product purchased by you accompanied by this document;
 - (d) 'ASR' means Residentia Group authorised service representative;
 - (e) 'Residentia Group' means Residentia Group Pty Ltd of 165 Barkly Ave, Burnley VIC 3121, ACN 70 600 546 656 in respect of Appliances purchased in Australia;
 - (f) 'major failure' as referred to in clause 10 of this warranty has the same meaning referred to in the ACL and includes a situation when an Appliance cannot be repaired or it is uneconomic for Residentia Group, at its discretion, to repair an Appliance during the Warranty Period;
 - (g) 'Warranty Period' means:
 - (i) where the Appliance is used for personal, domestic or household use (i.e. normal single family use) as set out in the instruction manual, the Appliance is warranted against manufacturing defects for 36 months, following the date of original purchase of the Appliance;
 - (h) 'you' means the purchaser of the Appliance not having purchased the Appliance for re-sale, and 'your' has a corresponding meaning.
2. This warranty only applies to Appliances purchased and used in Australia and is in addition to (and does not exclude, restrict, or modify in any way) any non-excludable statutory warranties in Australia.
3. During the Warranty Period Residentia Group or its ASR will, at no extra charge if your Appliance is readily accessible for service, without special equipment and subject to these terms and conditions, repair or replace any parts which it considers to be defective. Residentia Group or its ASR may use remanufactured parts to repair your Appliance. You agree that any replaced Appliances or parts become the property of Residentia Group. This warranty does not apply to light globes, batteries, seals, filters or similar perishable parts.
4. Parts and Appliances not supplied by Residentia Group are not covered by this warranty.

Warranty Information

5. You will bear the cost of transportation, travel and delivery of the Appliance to and from Residentia Group or its ASR. If you reside outside of the service area, you will bear the cost of:
 - (a) travel of an authorised representative;
 - (b) transportation and delivery of the Appliance to and from Residentia Group or its ASR, in all instances, unless the Appliance is transported by Residentia Group or its ASR, the Appliance is transported at the owner's cost and risk while in transit to and from Residentia Group or its ASR.
6. Proof of purchase is required before you can make a claim under this warranty.
7. You may not make a claim under this warranty unless the defect claimed is due to faulty or defective parts or workmanship. Residentia Group is not liable in the following situations (which are not exhaustive):
 - (a) the Appliance is damaged by:
 - (i) accident
 - (ii) misuse or abuse, including failure to properly maintain or service
 - (iii) normal wear and tear
 - (iv) power surges, electrical storm damage or incorrect power supply
 - (v) incomplete or improper installation
 - (vi) incorrect, improper or inappropriate operation
 - (vii) insect or vermin infestation
 - (viii) failure to comply with any additional instructions supplied with the Appliance;
 - (b) the Appliance is modified without authority from Residentia Group in writing;
 - (c) the Appliance's serial number or warranty seal has been removed or defaced;
 - (d) the Appliance was serviced or repaired by anyone other than Residentia Group, an authorised repairer or ASR.
8. This warranty, the contract to which it relates and the relationship between you and Residentia Group are governed by the law applicable where the Appliance was purchased.
9. To the extent permitted by law, Residentia Group excludes all warranties and liabilities (other than as contained in this document) including liability for any loss or damage whether direct or indirect arising from your purchase, use or non use of the Appliance.
10. For Appliances and services provided by Residentia Group in Australia, the Appliances come with a guarantee by Residentia Group that cannot be excluded under the Australian Consumer Law. You are entitled to a replacement or refund for a major failure and for compensation for any other reasonably foreseeable loss or damage. You are also entitled to have the Appliance repaired or replaced if the Appliance fails to be of acceptable quality and the failure does not amount to a major failure. The benefits to you given by this warranty are in addition to your other rights and remedies under a law in relation to the Appliances or services to which the warranty relates.
11. At all times during the Warranty Period, Residentia Group shall, at its discretion, determine whether repair, replacement or refund will apply if an Appliance has a valid warranty claim applicable to it.
12. Missing parts are not covered by warranty. Residentia Group reserves the right to assess each request for missing parts in a case by case basis. Any parts that are not reported missing in the first week after purchase will not provide free of charge.
13. To enquire about claiming under this warranty, please follow these steps:
 - (a) carefully check the operating instructions, user manual and the terms of this warranty;
 - (b) have the model and serial number of the Appliance available;
 - (c) have the proof of purchase (e.g. an invoice) available;
 - (d) telephone the numbers shown below.
14. You accept that if you make a warranty claim, Residentia Group and its ASR may exchange information in relation to you, in order to enable Residentia Group to meet its obligations under this warranty.

IMPORTANT

Before calling for service, please ensure that the steps in point 13 have been followed.

Contact Service: Please call 1300 11 HELP (4357)

The Australian Consumer Law requires the inclusion of the following statement with this warranty:

Our goods come with guarantees that cannot be excluded under the Australian Consumer Law. You are entitled to a replacement or refund for a major failure and for compensation for any other reasonably foreseeable loss or damage. You are also entitled to have the goods repaired or replaced if the goods fail to be of acceptable quality and the failure does not amount to a major failure.

EST. 1981

Designed to Enhance

omega