



**R18XPCS10**



## IMPORTANT!

It is essential that you read the instructions in this manual before assembling, operating, and maintaining the product.

Subject to technical modification.

Safety, performance, and dependability have been given top priority in the design of your cordless pruning saw.

## INTENDED USE

The cordless pruning saw is intended for outdoor use only. For safety reasons, the product must be adequately controlled by using a two-handed operation at all times.

The product is designed for cutting branches, trunks, logs, and beams of a diameter determined by the cutting length of the guide bar. It is designed to cut wood only.

The product is to be used in domestic applications only by adults who have received adequate training on the hazards and preventative measures to be taken while using the product. It should not be used for professional tree services.

Do not use the product for any other purpose.

## GENERAL PRODUCT SAFETY WARNINGS

**⚠ WARNING! Read all safety warnings, instructions, illustrations and specifications provided with this power tool.** Failure to follow all instructions listed below may result in electric shock, fire, and/or serious injury.

**Save all warnings and instructions for future reference.**

The term "power tool" in the warnings refers to your mains-operated (corded) product or battery-operated (cordless) product.

### WORK AREA SAFETY

- **Keep work area clean and well lit.** Cluttered or dark areas invite accidents.
- **Do not operate power tools in explosive atmospheres, such as in the presence of flammable liquids, gases or dust.** Power tools create sparks which may ignite the dust or fumes.
- **Keep children and bystanders away while operating a power tool.** Distractions can cause you to lose control.

### ELECTRICAL SAFETY

- **Power tool plugs must match the outlet. Never modify the plug in any way. Do not use any adapter plugs with earthed (grounded) power tools.** Unmodified plugs and matching outlets will reduce risk of electric shock.
- **Avoid body contact with earthed or grounded surfaces, such as pipes, radiators, ranges and refrigerators.** There is an increased risk of electric shock if your body is earthed or grounded.
- **Do not expose power tools to rain or wet conditions.** Water entering a power tool will increase the risk of electric shock.
- **Do not abuse the cord. Never use the cord for carrying, pulling or unplugging the power tool. Keep cord away from heat, oil, sharp edges or moving parts.** Damaged or entangled cords increase the risk of electric shock.

- **When operating a power tool outdoors, use an extension cord suitable for outdoor use.** Use of a cord suitable for outdoor use reduces the risk of electric shock.
- **If operating a power tool in a damp location is unavoidable, use a residual current device (RCD) protected supply.** Use of an RCD reduces the risk of electric shock.

### PERSONAL SAFETY

- **Stay alert, watch what you are doing and use common sense when operating a power tool. Do not use a power tool while you are tired or under the influence of drugs, alcohol or medication.** A moment of inattention while operating power tools may result in serious personal injury.
- **Use personal protective equipment. Always wear eye protection.** Protective equipment such as a dust mask, non-skid safety shoes, hard hat or hearing protection used for appropriate conditions will reduce personal injuries.
- **Prevent unintentional starting. Ensure the switch is in the off-position before connecting to power source and/or battery pack, picking up or carrying the tool.** Carrying power tools with your finger on the switch or energising power tools that have the switch on invites accidents.
- **Remove any adjusting key or wrench before turning the power tool on.** A wrench or a key left attached to a rotating part of the power tool may result in personal injury.
- **Do not overreach. Keep proper footing and balance at all times.** This enables better control of the power tool in unexpected situations.
- **Dress properly. Do not wear loose clothing or jewellery. Keep your hair and clothing away from moving parts.** Loose clothes, jewellery or long hair can be caught in moving parts.
- **If devices are provided for the connection of dust extraction and collection facilities, ensure these are connected and properly used.** Use of dust collection can reduce dust-related hazards.
- **Do not let familiarity gained from frequent use of tools allow you to become complacent and ignore tool safety principles.** A careless action can cause severe injury within a fraction of a second.

### POWER TOOL USE AND CARE

- **Do not force the power tool. Use the correct power tool for your application.** The correct power tool will do the job better and safer at the rate for which it was designed.
- **Do not use the power tool if the switch does not turn it on and off.** Any power tool that cannot be controlled with switch is dangerous and must be repaired.
- **Disconnect the plug from the power source and/or remove the battery pack, if detachable, from the power tool before making any adjustments, changing accessories, or storing power tools.** Such preventive safety measures reduce the risk of starting the power tool accidentally.
- **Store idle power tools out of the reach of children and do not allow persons unfamiliar with the power tool or these instructions to operate the power tool.**

Power tools are dangerous in the hands of untrained users.

- **Maintain power tools and accessories.** Check for misalignment or binding of moving parts, breakage of parts and any other condition that may affect the power tool's operation. If damaged, have the power tool repaired before use. Many accidents are caused by poorly maintained power tools.
- **Keep cutting tools sharp and clean.** Properly maintained cutting tools with sharp cutting edges are less likely to bind and are easier to control.
- **Use the power tool, accessories and tool bits etc. in accordance with these instructions, taking into account the working conditions and the work to be performed.** Use of the power tool for operations different from those intended could result in a hazardous situation.
- **Keep handles and grasping surfaces dry, clean and free from oil and grease.** Slippery handles and grasping surfaces do not allow for safe handling and control of the tool in unexpected situations.

#### BATTERY TOOL USE AND CARE

- **Recharge only with the charger specified by the manufacturer.** A charger that is suitable for one type of battery pack may create a risk of fire when used with another battery pack.
- **Use power tools only with specifically designated battery packs.** Use of any other battery packs may create a risk of injury and fire.
- **When battery pack is not in use, keep it away from other metal objects, like paper clips, coins, keys, nails, screws or other small metal objects, that can make a connection from one terminal to another.** Shorting the battery terminals together may cause burns or a fire.
- **Under abusive conditions, liquid may be ejected from the battery; avoid contact. If contact accidentally occurs, flush with water. If liquid contacts eyes, additionally seek medical help.** Liquid ejected from the battery may cause irritation or burns.
- **Do not use a battery pack or tool that is damaged or modified.** Damaged or modified batteries may exhibit unpredictable behaviour resulting in fire, explosion or risk of injury.
- **Do not expose a battery pack or tool to fire or excessive temperature.** Exposure to fire or temperature above 130°C may cause explosion.
- **Follow all charging instructions and do not charge the battery pack or tool outside the temperature range specified in the instructions.** Charging improperly or at temperatures outside the specified range may damage the battery and increase the risk of fire.

#### SERVICE

- **Have your power tool serviced by a qualified repair person using only identical replacement parts.** This will ensure that the safety of the power tool is maintained.
- **Never service damaged battery packs.** Service of battery packs should only be performed by the manufacturer or authorized service providers.

#### GENERAL PRUNING SAW SAFETY WARNINGS

- **Keep all parts of the body away from the saw chain when the pruning saw is operating. Before you start the pruning saw, make sure the saw chain is not contacting anything.** A moment of inattention while operating pruning saws may cause entanglement of your clothing or body with the saw chain.
- **Always hold the pruning saw with one hand on the rear handle and the other hand on the front handle.**
- **Hold the pruning saw by insulated gripping surfaces only, because the saw chain may contact hidden wiring.** Saw chains contacting a "live" wire may make exposed metal parts of the pruning saw "live" and could give the operator an electric shock.
- **Wear eye protection. Further protective equipment for hearing, head, hands, legs and feet is recommended.** Adequate protective equipment will reduce personal injury by flying debris or accidental contact with the saw chain.
- **Do not operate a pruning saw in a tree, on a ladder, from a rooftop, or any unstable support.** Operation of a pruning saw in this manner could result in serious personal injury.
- **Always keep proper footing and operate the pruning saw only when standing on fixed, secure and level surface.** Slippery or unstable surfaces may cause a loss of balance or control of the pruning saw.
- **When cutting a limb that is under tension, be alert for spring back.** When the tension in the wood fibres is released, the spring loaded limb may strike the operator and/or throw the pruning saw out of control.
- **Use extreme caution when cutting brush and saplings.** The slender material may catch the saw chain and be whipped toward you or pull you off balance.
- **Carry the pruning saw by the rear handle with the pruning saw switched off and away from your body. When transporting or storing the pruning saw, always fit the guide bar cover.** Proper handling of the pruning saw will reduce the likelihood of accidental contact with the moving saw chain.
- **Follow instructions for lubricating, chain tensioning and changing the bar and chain.** Improperly tensioned or lubricated chain may either break or increase the chance for kickback.
- **Cut wood only. Do not use pruning saw for purposes not intended. For example: do not use pruning saw for cutting metal, plastic, masonry or non-wood building materials.** Use of the pruning saw for operations different than intended could result in a hazardous situation.
- **This pruning saw is not intended for tree felling.** Use of the pruning saw for operations different than intended could result in serious injury to the operator or bystanders.
- **Follow all instructions when clearing jammed material, storing or servicing the pruning saw.** Make sure the switch is off and the battery pack is removed. Unexpected actuation of the pruning saw while clearing jammed material or servicing may result in serious personal injury.

## CAUSES AND OPERATOR PREVENTION OF KICKBACK:

Kickback may occur when the nose or tip of the guide bar touches an object, or when the wood closes in and pinches the saw chain in the cut.

Tip contact in some cases may cause a sudden reverse reaction, kicking the guide bar up and back towards the operator.

Pinching the saw chain along the top of the guide bar may push the guide bar rapidly back towards the operator.

Either of these reactions may cause you to lose control of the saw which could result in serious personal injury. Do not rely exclusively upon the safety devices built into your saw. As a pruning saw user, you should take several steps to keep your cutting jobs free from accident or injury.

Kickback is the result of pruning saw misuse and/or incorrect operating procedures or conditions and can be avoided by taking proper precautions as given below:

- **Maintain a firm grip, with thumb and fingers encircling the pruning saw rear handle, with both hands on the saw and position your body and arm to allow you to resist kickback forces.** Kickback forces can be controlled by the operator, if proper precautions are taken. Do not let go of the pruning saw.
- **Do not overreach and do not cut above shoulder height.** This helps prevent unintended tip contact and enables better control of the pruning saw in unexpected situations.
- **Only use replacement guide bars and saw chains specified by the manufacturer.** Incorrect replacement guide bars and saw chains may cause chain breakage and/or kickback.
- **Follow the manufacturer's sharpening and maintenance instructions for the saw chain.** Decreasing the depth gauge height can lead to increased kickback.

### ADDITIONAL SAFETY WARNINGS

- Attend a professionally organised course on the use and maintenance of pruning saws, preventative actions, and first aid. Keep these instructions safe for later use.
- Pruning saws are potentially dangerous tools. Accidents involving the use of pruning saws often result in loss of limbs or death. Falling branches, toppling trees, rolling logs can all kill. Diseased or rotting timber poses additional hazards. Assess your capability of completing the task safely. If there is any doubt, leave it to a professional tree surgeon.
- Do not cut vines or small undergrowth (less than 30 mm in diameter).
- It is recommended to practise cutting logs on a saw-horse or cradle when operating the product for the first time.
- The size of the work area depends on the job being performed and the size of the tree or workpiece involved. The operator needs to be aware and in control of everything happening in the work area.
- Do not use a back-and-forward sawing motion. Let the chain do the work. Keep the chain sharp, and do not try to push the chain through the cut.

- Do not put pressure on the saw at the end of the cut. Be ready to take on the weight of the saw as it cuts free from the wood. Failure to do so could result in possible serious personal injury.
- Do not stop the saw in the middle of a cutting operation. Keep the saw running until it is already removed from the cut.
- To reduce the risk of injury associated with contacting moving parts, always turn off the product, remove the battery pack, and make sure that all moving parts have come to a complete stop:
  - before cleaning or clearing a blockage
  - before leaving the product unattended
  - before installing or removing attachments
  - before checking, conducting maintenance, or working on the product
- Injuries may be caused, or aggravated, by prolonged use of the product. When using the product for prolonged periods, ensure to take regular breaks.
- If the product is dropped, suffers heavy impact, or begins to vibrate abnormally, immediately stop the product and inspect for damage or identify the cause of the vibration. Any damage should be properly repaired or replaced by an authorised service centre.
- Operate the product only in temperatures between 0°C and 40°C.
- Store the product in a location where the ambient temperature is between -10°C and 50°C.

### PERSONAL PROTECTIVE EQUIPMENT

Good quality personal protective equipment, as used by professionals, helps reduce the risk of injury to the operator. The following items should be used when operating the product:

- Safety helmet
- Hearing protection
- Eye and face protection
- Gloves
- Leg protection (chaps)
- Pruning saw safety boots
- Pruning saw jackets for upper body protection

### ADDITIONAL BATTERY SAFETY WARNINGS

- To reduce the risk of fire, personal injury, and product damage due to short circuit, never immerse the tool, battery pack, or charger in fluid or allow fluid to flow inside them. Corrosive or conductive fluids, such as seawater, certain industrial chemicals, and bleach or bleach-containing products, etc., can cause a short circuit.
- Charge the battery pack in a location where the ambient temperature is between 10°C and 38°C.
- Store the battery pack in a location where the ambient temperature is between 0°C and 20°C.

## INSTRUCTIONS CONCERNING THE PROPER TECHNIQUES FOR BASIC LIMBING AND CROSS-CUTTING

### UNDERSTANDING THE FORCES WITHIN THE WOOD

When you understand the directional pressures and stresses inside the wood, you can reduce the pinches or at least expect them during your cutting. Tension in the wood means the fibres are being pulled apart, and if you cut in this area, the kerf or cut tends to open as the saw goes through. If a log is being supported on a saw-horse and the end is hanging unsupported over the end, tension is created on the upper surface due to the weight of the overhanging log stretching the fibres. Likewise, the underside of the log is compressed and the fibres are being pushed together. If a cut is made in this area, the kerf tends to close up during the cut. This cut would pinch the blade.

### PUSH AND PULL

The reaction force is always opposite to the direction the chain is moving. The operator must be ready to control the tendency for the product to pull away and push backwards. The product pulls away (forward motion) when cutting on the bottom edge of the bar. The product pushes backwards (towards the operator) when cutting along the top edge.

### SAW JAMMED IN THE CUT

Turn off the product, and remove the battery pack. Do not try to force the chain and bar out of the cut as this is likely to break the chain, which may swing back and strike the operator. This situation normally occurs because the wood is incorrectly supported, which forces the cut to close under compression, thereby pinching the blade. If adjusting the support does not release the bar and chain, use wooden wedges or a lever to open the cut and release the saw. Never try to start the pruning saw when the guide bar is already in a cut or kerf.

### SKATING/BOUNCING

When the pruning saw fails to dig in during a cut, the guide bar can begin hopping or dangerously skidding along the surface of the log or branch, possibly resulting in the loss of control of the pruning saw. To prevent or reduce skating or bouncing, always use the saw with both hands. Make sure that the saw chain establishes a groove for cutting.

Never cut small, flexible branches or brushes with your pruning saw. Their size and flexibility can easily cause the saw to bounce towards you or bind up with enough force to cause a kickback. The best tool for that kind of work is a hand saw, pruning shears, an axe, or other hand tools.

### BUCKING A LOG

Bucking is cutting a log into lengths. It is important to make sure your footing is firm and your weight is evenly distributed on both feet. When possible, the log should be raised and supported by the use of limbs, logs or chocks. Follow the simple directions for easy cutting. When the log is supported along its entire length, it is cut from the top (overbuck).

When the log is supported on one end, cut 1/3 the diameter from the underside (underbuck). Then make the finished cut by overbuckling to meet the first cut.

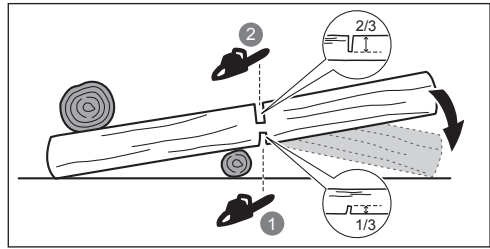

When the log is supported on both ends, cut 1/3 the diameter from the top (overbuck). Then make the finished cut by underbuckling the lower 2/3 to meet the first cut.

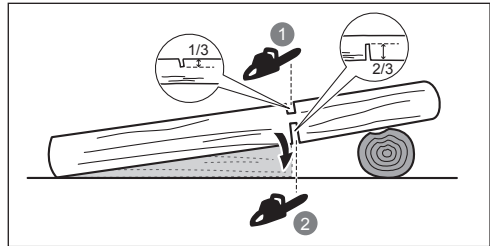

When bucking on a slope always stand on the uphill side of the log. To maintain control when “cutting through”, release the cutting pressure near the end of the cut without relaxing your grip on the pruning saw handles. Do not let the chain contact the ground. After completing the cut, wait for the saw chain to stop before you move the pruning saw. Always stop the motor before moving from tree to tree.

### LIMBING A TREE

Limbing is removing the branches from a fallen tree. When limbing, leave larger lower limbs to support the log off the ground. Remove the small limbs in one cut. Branches under tension should be cut from the bottom up to avoid binding the pruning saw.

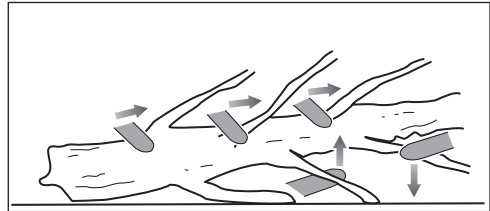

### SPRINGPOLES

A springpole is any log, branch, rooted stump, or sapling that is bent under tension by other wood so that it springs back if the wood holding it is cut or removed.

On a fallen tree, a rooted stump has a high potential of springing back to the upright position during the bucking cut to separate the log from the stump. Watch out for springpoles—they are dangerous. Do not attempt to cut bent branches or stumps that are under tension unless you are professionally trained and competent to do so.

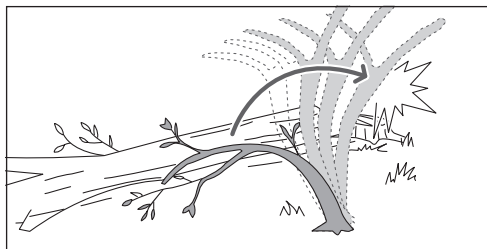

**⚠ WARNING!** Springpoles are dangerous and could strike the operator, causing the operator to lose control of the pruning saw. This could result in a severe or fatal injury to the operator. Cutting spring poles should be done by trained users.

### TRANSPORTATION AND STORAGE

- Turn off the product, remove the battery pack, and allow the product to cool down before storing or transporting.
- Remove all foreign materials from the product. Store the product in a cool, dry, and well-ventilated place that is inaccessible to children. Keep the product away from corrosive agents, such as garden chemicals and de-icing salts. Do not store the product outdoors.
- Fit the guide bar cover before storing the product or during transportation.
- For transportation, secure the product against movement or falling to prevent injury to persons or damage to the product.

### TRANSPORTING LITHIUM BATTERIES

Transport the battery in accordance with local and national provisions and regulations.

Follow all special requirements on packaging and labelling when transporting batteries by a third party. Ensure that no batteries can come in contact with other batteries or conductive materials while in transport by protecting exposed connectors with insulating, non-conductive caps or tape. Do not transport batteries that are cracked or leaking. Check with the forwarding company for further advice.

### MAINTENANCE

- Use only original manufacturer's replacement parts, accessories, and attachments. Failure to do so can cause possible injury, can contribute to poor performance, and may void your warranty.
- Servicing requires extreme care and knowledge and should be performed only by a qualified service technician. Have the product serviced by an authorised service centre only.
- You may make adjustments or repairs described in this manual. For other repairs, have the product serviced by an authorised service centre only.
- Consequences of improper maintenance, removal, or modification of safety devices, may cause the product to not function correctly, increasing the potential for serious injury. Keep the product professionally maintained.
- Sharpening the chain safely is a difficult precision task that should be performed only by experienced skilled professionals. The manufacturer strongly recommends that a worn or dull chain is replaced with a new one,

available at your authorised service centre. The part number is available in the product specification table in this manual.

- Follow the instructions for lubricating and chain tension checking and adjustment.
- After each use, clean the plastic parts with a soft, dry cloth.
- Check all nuts, bolts, and screws at frequent intervals for security to ensure that the product is in safe working condition. Any part that is damaged should be properly repaired or replaced by an authorised service centre.

### MAINTENANCE SCHEDULE

#### Daily check

Bar lubrication	Before each use
Chain tension	Before each use and frequently
Chain sharpness	Before each use (visual check)
For damaged parts	Before each use
For loose fasteners	Before each use

#### Inspect and clean

Bar	Before each use
Complete saw	After each use

### SAFETY DEVICES

#### CHAIN CATCHER

The chain catcher prevents the saw chain from being thrown back towards the operator if the saw chain comes loose or breaks.

#### GUIDE BARS

Generally, guide bars with small radius tips have a somewhat lower potential for kickback. Use a guide bar and matching chain that is just long enough for the job. Longer bars increase the risk of loss of control during sawing. Regularly check the chain tension. When cutting smaller branches (less than the full length of the guide bar) the chain is more likely to be thrown off if the tension is not correct.

#### LOW-KICKBACK SAW CHAIN

The low-kickback saw chain helps to reduce the possibility of a kickback event.

The rakers (depth gauges) ahead of each cutter can minimise the force of a kickback reaction by preventing the cutters from digging in too deeply. Use only replacement guide bar and chain combinations that are recommended by the manufacturer.

As saw chains are sharpened, they lose some of the low-kickback qualities, and extra caution is required. For safety, replace saw chains when cutting performance decreases.

#### OVER-TEMPERATURE PROTECTION

The battery pack has over-temperature protection, which is designed to protect the battery cells from damage in the event of high temperatures. This feature may cause the battery to stop powering the product until the battery cells cool down. If the battery pack is warm to touch, allow it to cool down before resuming operation. If the product still

does not work, connect the battery pack to the charger, which can also indicate over-temperature protection. When the battery cells cool down, the charger begins to charge the battery.

**NOTE:** High ambient temperatures above 30° C and high-power tools, such as saws, can cause the battery cells to heat up faster. Monitor the battery pack regularly, and if it is warm to touch, change the battery or allow the battery to cool down.

**NOTE:** The battery pack LED indicator stops working if the battery protection feature has caused the battery pack to stop powering the product.

#### LOAD SENSING LED PANEL

LED	Status	Action
Green	Normal load	-
Amber	High load	<ul style="list-style-type: none"> <li>■ Do not apply excess pressure during a cut.</li> <li>■ Check the chain quality. Sharpen or replace the chain when needed.</li> <li>■ Check the chain tension.</li> </ul>
Red	Overloaded	<ul style="list-style-type: none"> <li>■ Check the cutting condition.</li> <li>■ Check the chain quality. Sharpen or replace the chain when needed.</li> <li>■ Do not apply excess pressure during a cut.</li> <li>■ Check the chain tension.</li> </ul>



Do not operate the saw using only one hand.



Waste electrical products should not be disposed of with household waste. Please recycle where facilities exist. Check with your local authority or retailer for recycling advice.



Regulatory Compliance Mark (RCM). Product meets applicable regulatory requirements.



Guaranteed sound power level



Rotate to adjust the chain tension  
+ = Tighten the chain  
- = Loosen the chain



Moving direction of the chain.  
(Marked under the sprocket cover)

#### SYMBOLS IN THIS MANUAL



Parts or accessories sold separately



Note



Warning



Wear eye and face protection.



Wear upper body protection.



Wear leg protection.



Stop the product.

#### SYMBOLS ON THE PRODUCT



Safety alert



Read and understand all instructions before operating the product. Follow all warnings and safety instructions.



Wear eye, ear, and head protection.



Wear non-slip safety footwear when using the product.



Wear non-slip, heavy-duty gloves.



Beware of pruning saw kickback and avoid contact with bar tip.



Do not expose the product to rain or damp conditions.



Hold and operate the saw properly with both hands.





# R18XPCS10

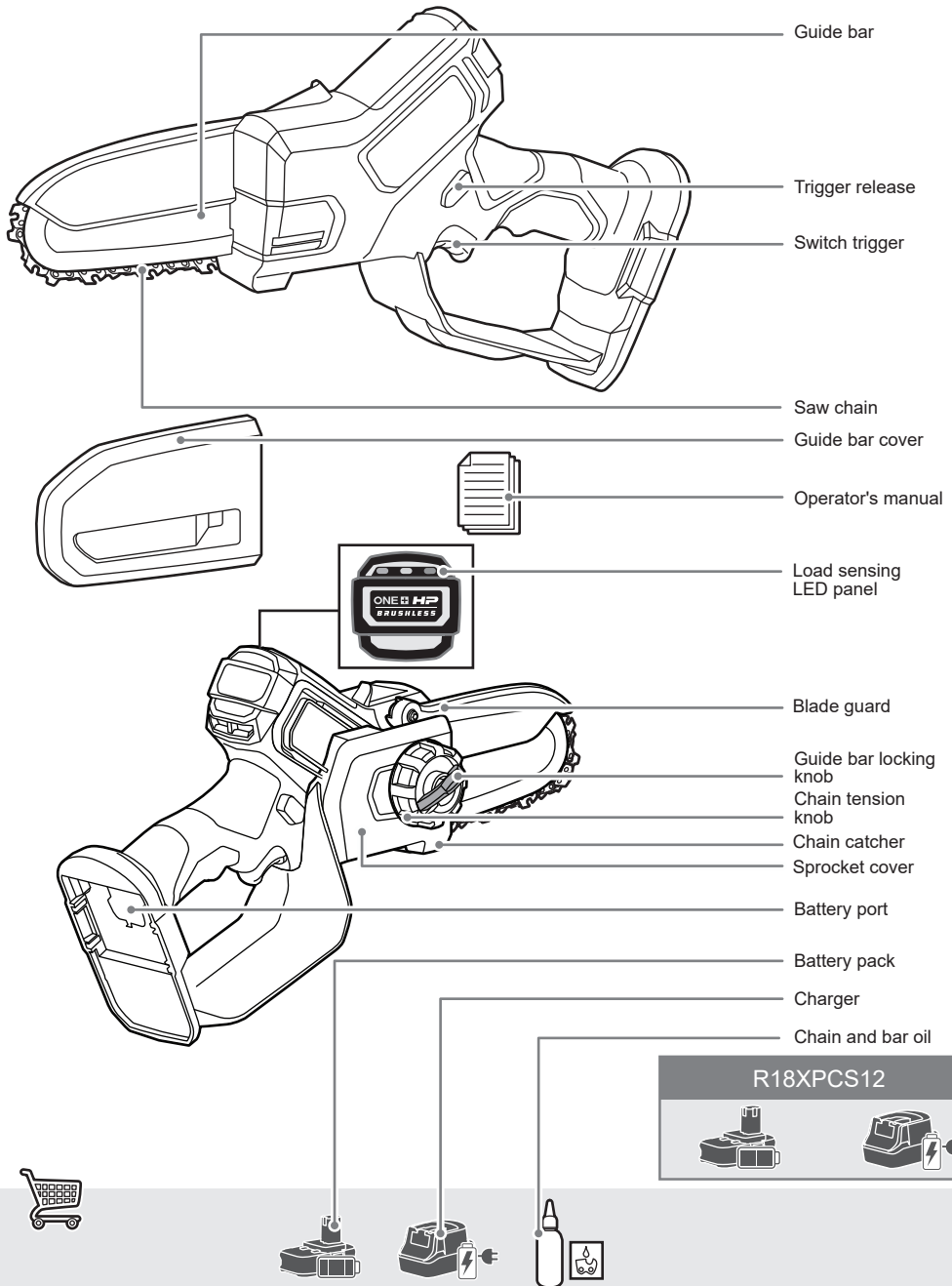

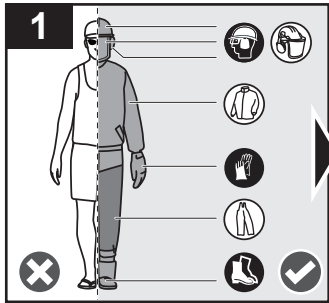

**1** Wear Personal Protective Equipment (PPE). Wear full eye protection, ear protection, non-slip heavy-duty gloves, substantial footwear, and protective clothing at all times while operating the product. Do not operate the product when barefoot or wearing open sandals.

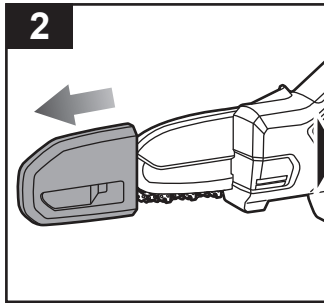

**2** Remove the guide bar cover.

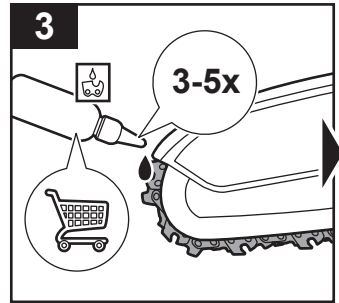

**3** Add 3-5 drops of chain and bar oil to the saw chain. Never work without chain and bar oil. If the saw chain is running without lubricant, the guide bar and the saw chain can be damaged.

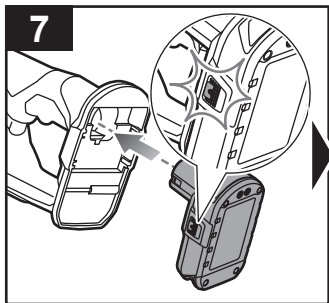

**7** Install the battery pack. Make sure that the latch of the battery pack clicks in place and that the battery pack is fully seated and securely attached before beginning operation.

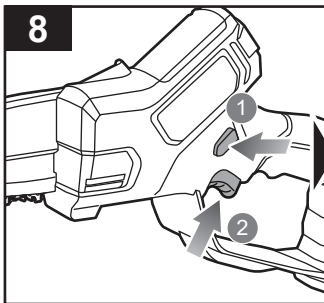

**8** Press the trigger release and squeeze the switch trigger.

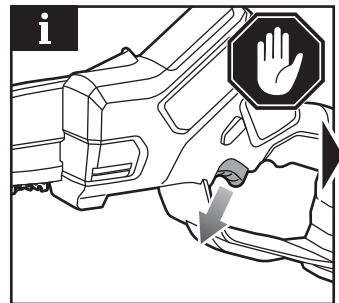

**i** **NOTE:** To stop the product, release the switch trigger.

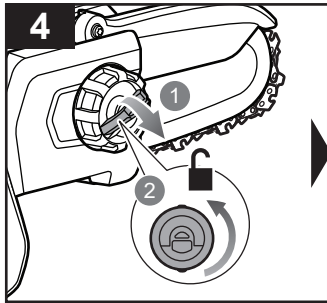

4 Pull up the guide bar locking knob, then turn it counterclockwise to unlock.

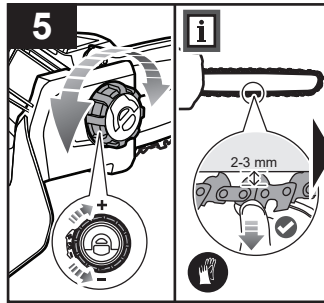

5 To increase the chain tension, turn the chain tension knob clockwise. To reduce the chain tension, turn the chain tension knob counterclockwise.

**NOTE:** The chain tension is correct when the gap between the cutter in the chain and the bar is between 2 and 3 mm.

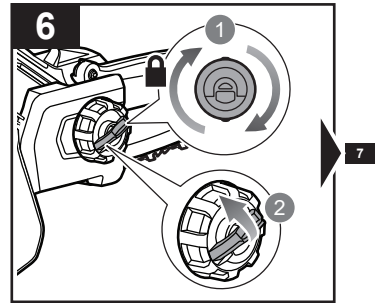

6 Rotate the guide bar locking knob clockwise, then push it back into position to lock.

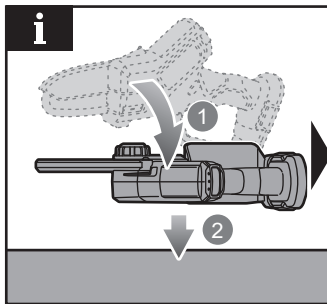

**NOTE:** When resting in between operation, lay the product on its side.

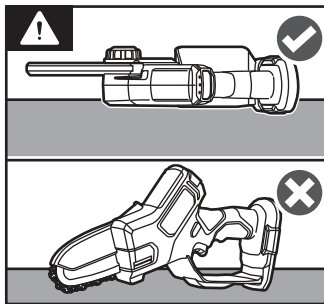

**WARNING:** Lay the product on its side when not in use. Do not use the saw chain and bar as a support to avoid injury.

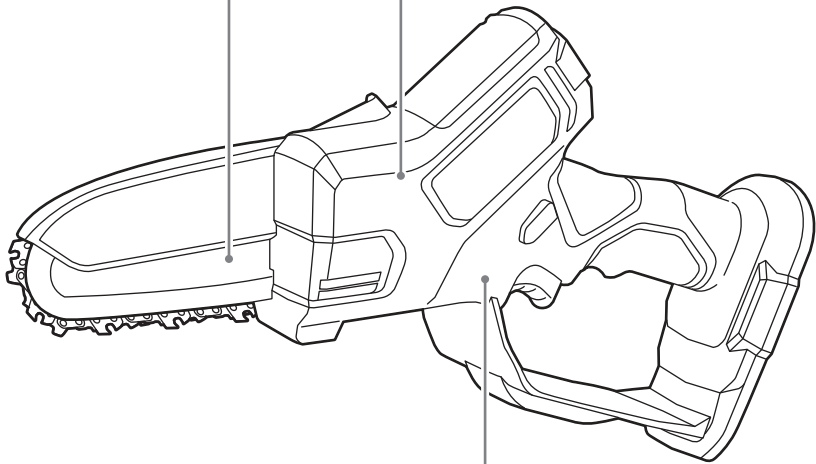

Replacing the bar and saw chain **p.13**

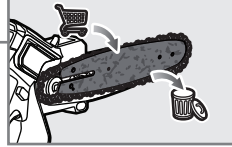

Cleaning the product **p.15**

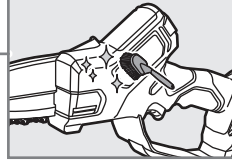

Storing the product **p.16**

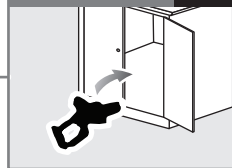

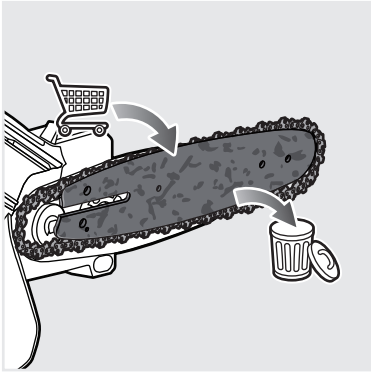

### REPLACING THE BAR AND SAW CHAIN

1. Remove the battery pack.
2. Pull up the guide bar locking knob, then turn it counterclockwise to unlock.
3. Turn the chain tension knob counterclockwise.
4. Remove the guide bar locking knob, chain tension knob, and sprocket cover.
5. Remove the bar and saw chain assembly.

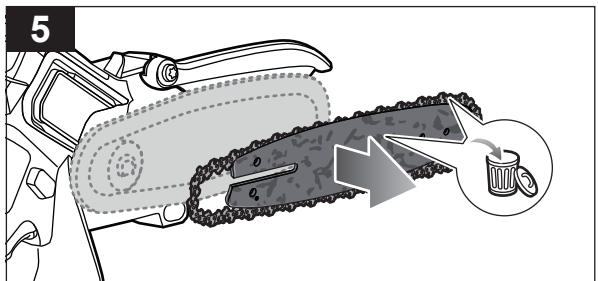
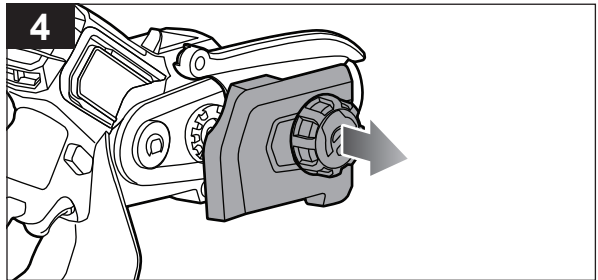
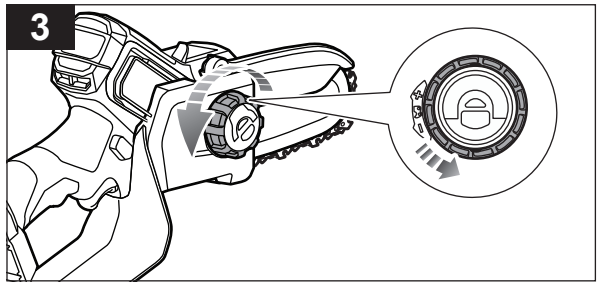
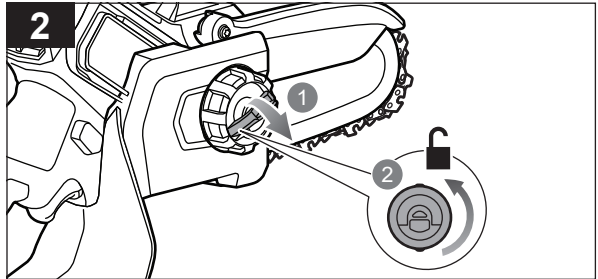
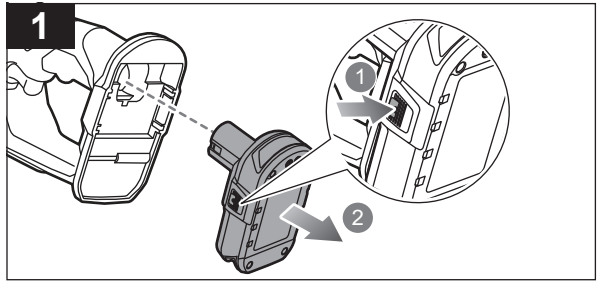

6. Install the new chain on the bar.

Insert the chain drive links into the bar groove. Position the chain so that there is a loop at the back of the bar.

**NOTE:** The saw chain should face in the direction of chain rotation. If the saw chain faces backwards, turn the loop over.

7. Hold the chain in position on the bar, and place the loop around the drive sprocket. Lower the bar and place it flush against the mounting surface.

8. Reinstall the sprocket cover, guide bar locking knob, and chain tension knob.

9. Adjust the chain tension until the gap between the drive teeth and bar is between 2 and 3 mm.

To increase the chain tension, turn the chain tension knob clockwise.

To reduce the chain tension, turn the chain tension knob counterclockwise.

**NOTE:** Frequently check the chain tension while turning the chain tensioning screw.

10. Turn the guide bar locking knob clockwise then push it back into position to lock.

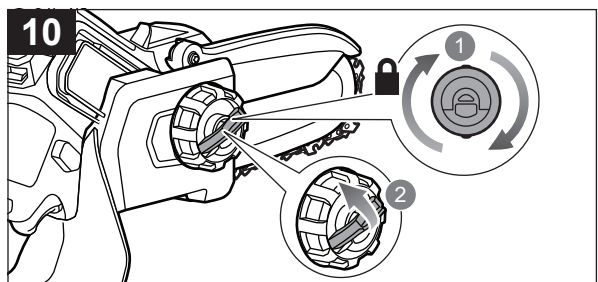
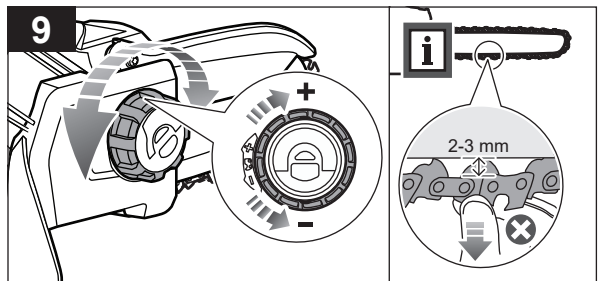
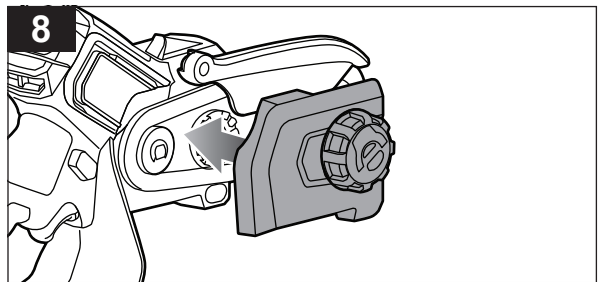
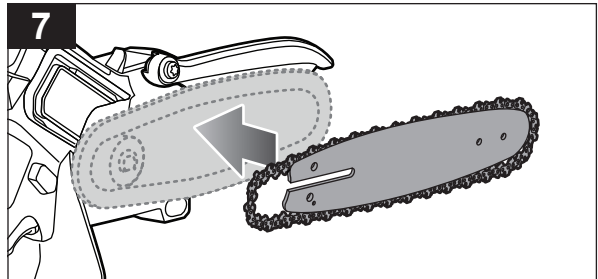
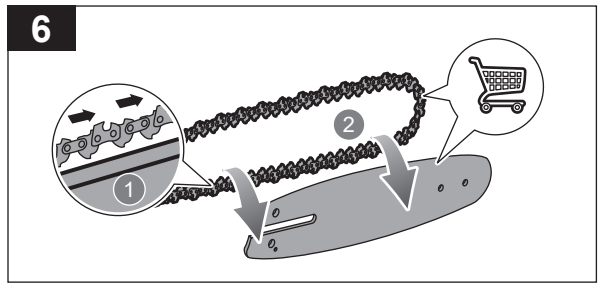

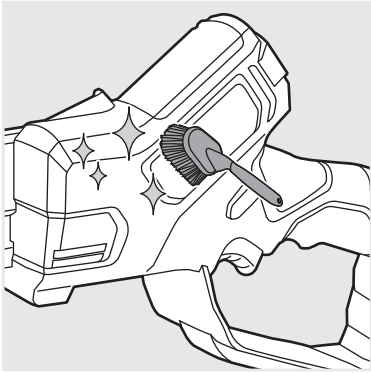

### CLEANING THE PRODUCT

1. Remove the battery pack.
2. Use a brush to remove loose dirt and saw dust from around the front hand guard. Use a soft, dry cloth to clean the plastic parts.

**WARNING:** Do not use water to clean the product.

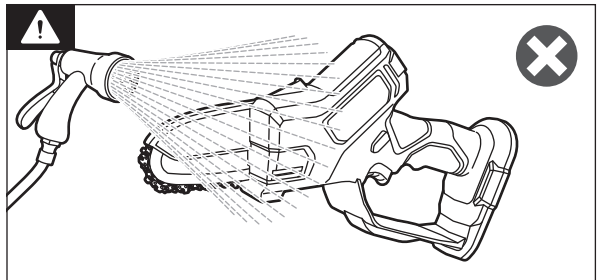
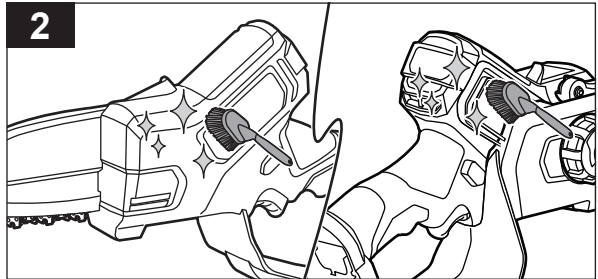
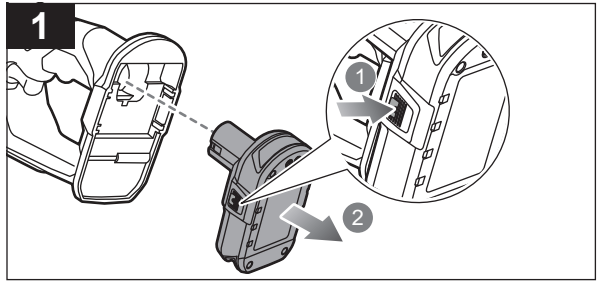

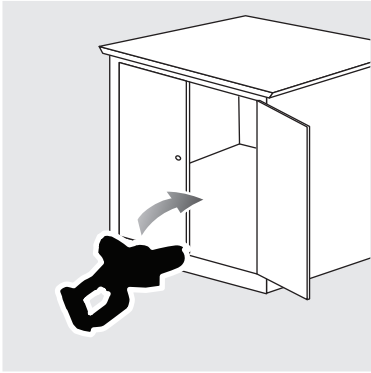

### STORING THE PRODUCT

1. Remove the battery pack.
2. Install the guide bar cover.
3. When transporting the product, secure it against movement or falling to prevent injury to persons or damage to the product.

Store the product in a cool, dry, and well-ventilated place that is inaccessible to children. Keep the product away from corrosive agents, such as garden chemicals and de-icing salts. Do not store the product outdoors.

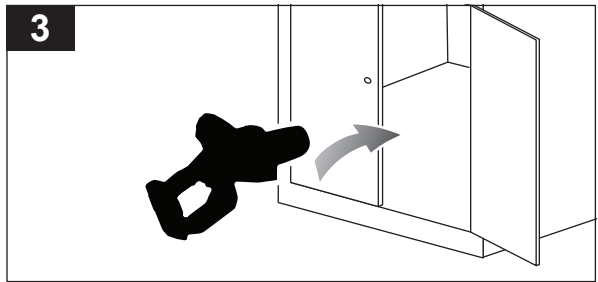
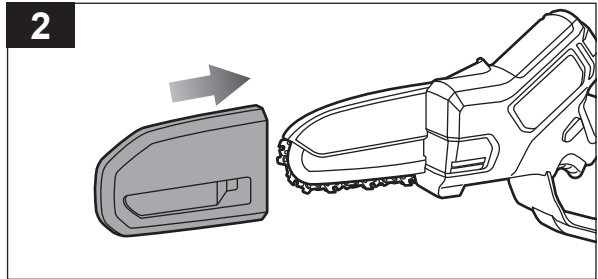
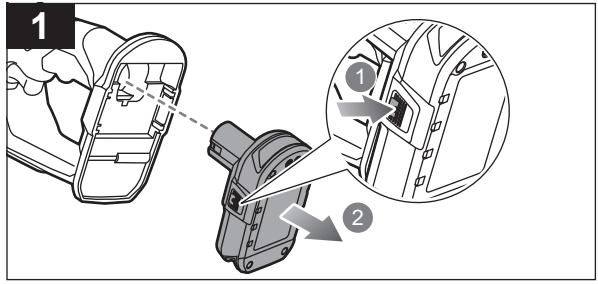



## PRODUCT SPECIFICATIONS

Cordless pruning saw	
Model	R18XPCS10
Rated voltage	18 V d.c.
No-load speed	6 m/s
Guide bar length	152.4 mm (6 in.)
Usable cutting length	145 mm (5.7 in.)
Chain stopping time	< 2 s
Chain length	152.4 mm (6 in.)
Chain pitch	8.255 mm (0.325 in.)
Chain gauge	1.09 mm (0.043 in.)
Drive links quantity	30
Weight (without battery pack, guide bar, chain, and oil)	0.98 kg
Vibration level (in accordance with IEC 62841-1 and IEC 62841-4-1)	
Front handle	3.9 m/s <sup>2</sup>
Rear handle	3.4 m/s <sup>2</sup>
Uncertainty of measurement	1.5 m/s <sup>2</sup>
Noise emission level (in accordance with IEC 62841-1 and IEC 62841-4-1)	
A-weighted sound pressure level at the operator's position	79.0 dB(A)
Uncertainty of measurement	3.0 dB
A-weighted sound power level	87.0 dB(A)
Uncertainty of measurement	3.0 dB
Sound power level (in accordance with ISO 3744, 2000/14/EC amended by 2005/88/EC)	
Measured sound power level	94.1 dB(A)
Guaranteed sound power level	96.0 dB(A)

## BATTERY AND CHARGER

Model	R18XPCS12	R18XPCS10
Battery pack	RB1820C	-
Charger	RC18115	-
Compatible battery packs	RB18L15B, RB1820C, RB18L20A, RB1825C, RB18L25A, RB18L40A, RB1840C, RB18L50A, RB18L60A, RB1860X	

## REPLACEMENT PARTS

Manufacturer	OREGON	RYOBI
Chain	80BX030XTR	RCHC6
Bar	637969	319739005

The chain must be fitted with the bar from the same manufacturer according to above combinations.

## MAINTENANCE TOOL

Saw file	4.0 mm (5/32 in.)
----------	-------------------

**⚠ WARNING!** The declared vibration total values and the declared noise emission values given in this instruction manual have been measured in accordance with a standardised test and may be used to compare one tool with another. They may be used for a preliminary assessment of exposure.

The declared vibration and noise emission values represent the main applications of the tool. However, if the tool is used for different applications, used with different accessories, or poorly maintained, the vibration and noise emission may differ. These conditions may significantly increase the exposure levels over the total working period.

An estimation of the level of exposure to vibration and noise should take into account the times when the tool is turned off or when it is running idle. These conditions may significantly reduce the exposure level over the total working period.

Identify additional safety measures to protect the operator from the effects of vibration and noise, such as maintaining the tool and the accessories, keeping the hands warm (in case of vibration), and organising work patterns.





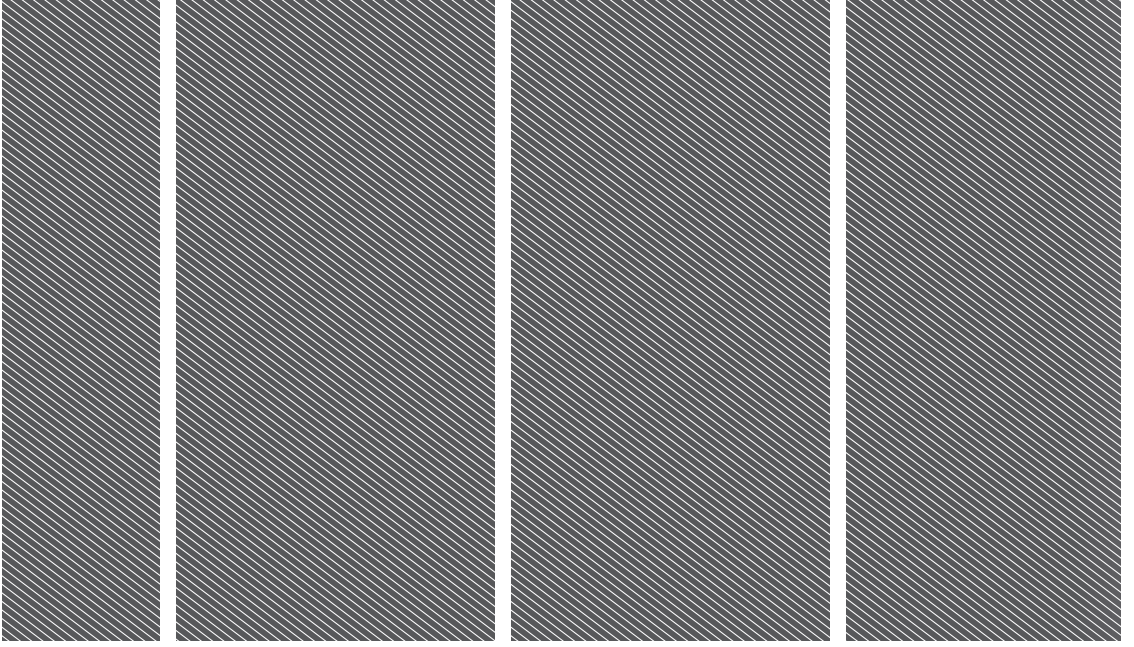

Imported by:

**Techtronic Industries Australia Pty Ltd**

31 Gilby Road, Mount Waverley, VIC 3149  
Melbourne, Australia

**Techtronic Industries N.Z. Limited**

Unit C, 70 Business Parade South,  
Highbrook, Auckland 2013, New Zealand

*RYOBI is a trade mark of Ryobi Limited, and is used under license.*

*OREGON is a registered trade mark of Blount, Inc.*

961087507-02

