



RLL18



## IMPORTANT!

It is essential that you read the instructions in this manual before assembling, operating, and maintaining the product.

Subject to technical modifications.

Safety, performance, and dependability have been given top priority in the design of your lantern.

## INTENDED USE

The lantern is intended for general illumination. Do not use the product in wet conditions.

Do not use the product for any other purpose. Use of the product for operations different from intended could result in a hazardous situation.

## LANTERN SAFETY WARNINGS

- The light source of this luminaire is not replaceable. When the light source reaches its end of life the whole luminaire shall be replaced.
- Use only with recommended battery pack and charger. Any attempt to use another battery pack will cause damage to the product and could possibly explode, cause a fire, or personal injury.
- Do not disassemble the product.
- If wrapped or in contact with fabrics, the lens can produce sufficient heat to melt some fabrics. To avoid serious personal injury, never allow the lens to come in contact with anything.
- Do not place the product or battery pack near fire or heat. This will reduce the risk of explosion and possible injury.
- Remove the battery pack before

starting any work on the product.

- Do not store the product in a damp or wet location, or in a location where the temperature may reach or exceed 40°C. For example, inside sheds, vehicles, or metal buildings in the summer.

## BATTERY SAFETY WARNINGS

- To reduce the risk of fire, personal injury, and product damage due to a short circuit, never immerse your tool, battery pack or charger in fluid or allow a fluid to flow inside them. Corrosive or conductive fluids, such as seawater, certain industrial chemicals, and bleach or bleach-containing products, etc., can cause a short circuit.

## TRANSPORTING LITHIUM BATTERIES

Transport the battery in accordance with local and national provisions and regulations.

Follow all special requirements on packaging and labelling when transporting batteries by a third party. Ensure that no batteries can come in contact with other batteries or conductive materials while in transport by protecting exposed connectors with insulating, non-conductive caps or tape. Do not transport batteries that are cracked or leaking. Check with the forwarding company for further advice.

## MAINTENANCE

- Use only original accessories and spare parts. Should components need to be replaced which have not been described, please contact an authorised service centre. All repairs should be performed by an

authorised service centre.

- Avoid using solvents when cleaning plastic parts. Most plastics are susceptible to various types of commercial solvents and may be damaged by their use. Use clean cloths to remove dirt, carbon dust, etc.
- Do not at any time let brake fluids, gasoline, petroleum-based products, penetrating oils, etc., come in contact with plastic parts. Chemicals can damage, weaken or destroy plastic which may result in serious personal injury.



Class III protection



Do not stare at light source.



Waste electrical products should not be disposed of with household waste. Please recycle where facilities exist. Check with your Local Authority or retailer for recycling advice.

## ENVIRONMENTAL PROTECTION



Recycle raw materials instead of disposing of as waste. The machine, accessories and packaging should be sorted for environmental-friendly recycling.

## SYMBOLS IN THIS MANUAL



Note



Parts or accessories sold separately

## SYMBOLS



Safety Alert

V

Volts



Direct current



Regulatory Compliance Mark (RCM). Product meets applicable regulatory requirements.



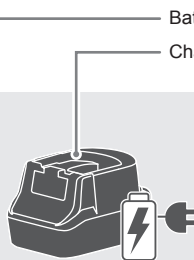
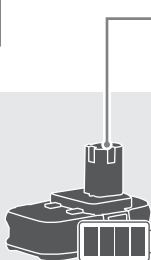
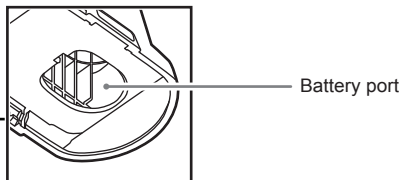
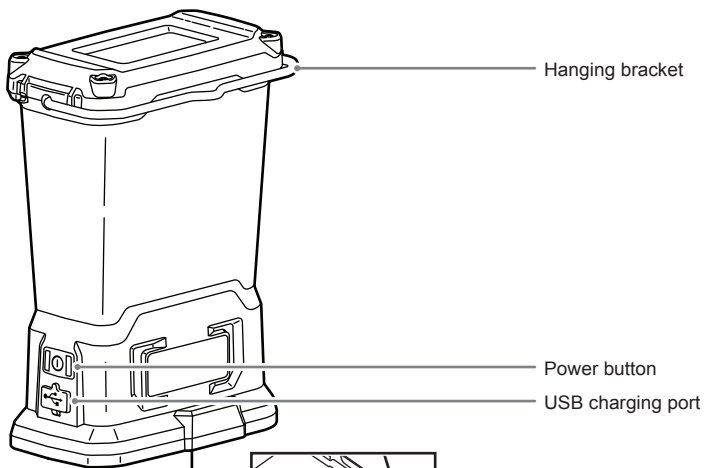

Please read the instructions carefully before starting the product.

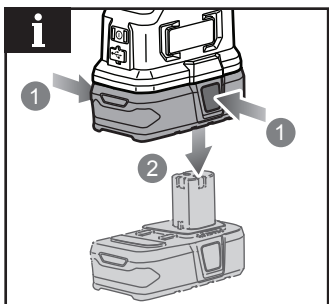
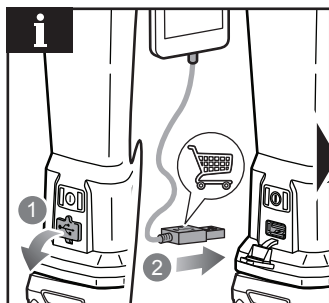
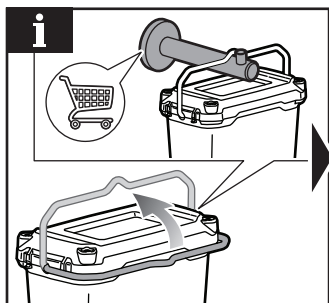
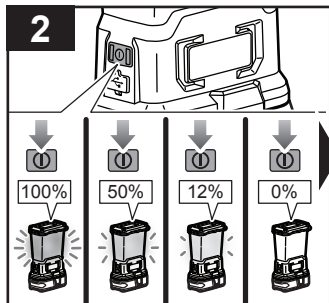
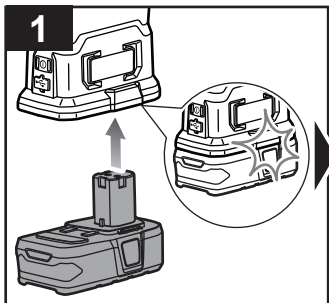



## PRODUCT SPECIFICATIONS

### LED lantern

Model	RLL18
Voltage	18 V 
Wattage	22 W
Light output (Lumens)	
High brightness level	850 Lum
Medium brightness level	430 Lum
Low brightness level	100 Lum
Colour rendering index (CRI)	80
Correlated colour temperature (CCT)	4000 K
USB output	5 V 
USB output current	2.1 A
Weight - excluding battery pack	0.45 kg

## BATTERY AND CHARGER

Model	Compatible battery pack (not included)	Compatible charger (not included)
Lithium-Ion	RB18L13	
	RB18L15	
	RB18L15A	
	RB18L15B	
	RB18L20	
	RB18L20A	BCS618G
	RB18L25	BCL14181H
	RB18L25A	BCL14183H
	RB18L40	BCL1418IV*
	RB18L40A	RC18150U
	RB18L50	RC18627U
	RB18L50A	RC18120
	RB18L60A	RC18115
	RB18L90A	
	RB1815C	
	RB1820C	
RB1840C		
RB1840X		

\* for vehicles with 12V DC outlets



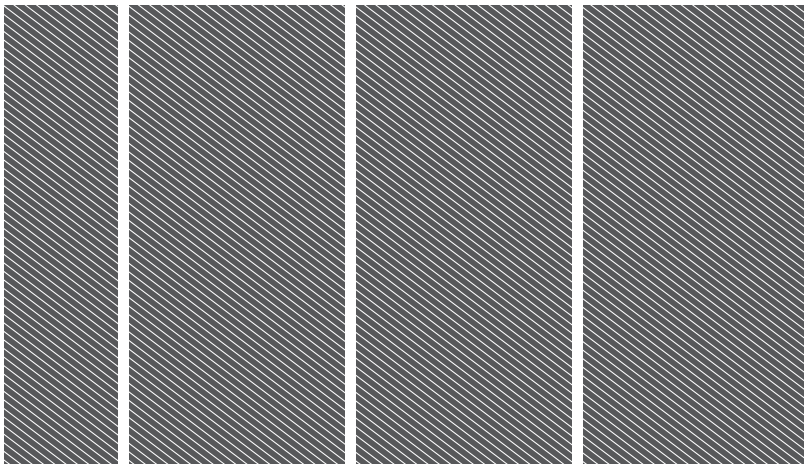

Imported by:  
**Techtronic Industries Australia Pty Ltd**  
31 Gilby Road, Mount Waverley,  
VIC, 3149, Australia

**Techtronic Industries N.Z. Limited**  
Unit C, 70 Business Parade South,  
Highbrook, Auckland 2013, New Zealand

*RYOBI is a trade mark of Ryobi Limited, and is used under license.*

20210726v1

