



ORIGINAL INSTRUCTIONS
USB Lithium Magnetic Clamp Light
RMCL4

IMPORTANT!

It is essential that you read the instructions in this manual before assembling, operating, and maintaining the product.
 Subject to technical modifications.

Safety, performance, and dependability have been given top priority in the design of your clamp light.

INTENDED USE

The light is intended for both indoor and outdoor general illumination.

The product is intended for use only when it is clamped. Do not use the product with it resting on any surface.

With the magnetic function, the product can be attached to horizontal metal surfaces only.

The product is not intended for clamping on smooth surfaces or tubular materials.

When clamping, the material being clamped must be pushed to the deepest point of the clamp for increased stability. Check and make sure that the product clamps firmly.

Do not place or hang anything on the product.

Do not use the product for any other purpose. Use of the product for operations different from intended could result in a hazardous situation.

LIGHT SAFETY WARNINGS

- The light source of this luminaire is not replaceable. When the light source reaches its end of life the whole luminaire shall be replaced.
- Use only with recommended battery pack and charger. Any attempt to use another battery pack will cause damage to the product and could possibly explode, cause a fire, or personal injury.
- Do not disassemble the product.
- If wrapped or in contact with fabrics, the lens can produce sufficient heat to melt some fabrics. To avoid serious personal injury, never allow the lens to come in contact with anything.
- Do not place the product or battery pack

near fire or heat. This will reduce the risk of explosion and possible injury.

- Remove the battery pack or disconnect the mains power before starting any work on the product.
- Do not store the product in a damp or wet location, or in a location where the temperature may reach or exceed 40°C. For example, inside sheds, vehicles, or metal buildings in the summer.
- Do not direct the light beam at persons or animals and do not stare into the light beam yourself (not even from a distance). Staring into the light beam may result in serious injury or vision loss.
- With the magnets in the base, the product can be mounted on a 22-gauge low carbon steel surface with a minimum thickness of 0.6 mm.

BATTERY SAFETY WARNINGS

- To reduce the risk of fire, personal injury, and product damage due to a short circuit, never immerse your tool, battery pack, or charger in fluid or allow fluid to flow inside them. Corrosive or conductive fluids, such as seawater, certain industrial chemicals, and bleach or bleach-containing products, etc., can cause a short circuit.

TRANSPORTING LITHIUM BATTERIES

Transport the battery in accordance with local and national provisions and regulations.

Follow all special requirements on packaging and labelling when transporting batteries by a third party. Ensure that no batteries can come in contact with other batteries or conductive materials while in transport by protecting exposed connectors with insulating, non-conductive caps or tape. Do not transport batteries that are cracked or leaking. Check with the forwarding company for further advice.

MAINTENANCE

- Use only original accessories and spare parts. Should components that have not been described need to be replaced, please contact an authorised service centre. All repairs should be performed by an authorised service centre.
- Avoid using solvents when cleaning plastic parts. Most plastics are susceptible to various types of commercial solvents and may be damaged by their use. Use clean cloths to remove dirt, carbon dust, etc.
- Do not at any time let brake fluids, gasoline, petroleum-based products, penetrating oils, etc., come in contact with plastic parts. Chemicals can damage,

weaken or destroy plastic which may result in serious personal injury.

SYMBOLS

- Direct current
- Regulatory Compliance Mark (RCM). Product meets applicable regulatory requirements.
- Please read the instructions carefully before starting the product.
- Do not stare at the operating light source.
- Class III protection
- Do not dispose of waste batteries, waste electrical and electronic equipment as unsorted municipal waste. Waste batteries and waste electrical and electronic equipment must be collected separately. Waste batteries, waste accumulators, and light sources have to be removed from the equipment. Check with your local authority or retailer for recycling advice and collection point. According to local regulations, retailers may have an obligation to take back waste batteries and waste electrical and electronic equipment free of charge. Your contribution to the reuse and recycling of waste batteries and waste electrical and electronic equipment helps to reduce the demand of raw materials. Waste batteries, in particular containing lithium, and waste electrical and electronic equipment contain valuable and recyclable materials, which can adversely impact the environment and the human health if not disposed of in an environmentally compatible manner. Delete personal data from waste equipment, if any.

SYMBOLS IN THIS MANUAL

- Note
- Parts or accessories sold separately

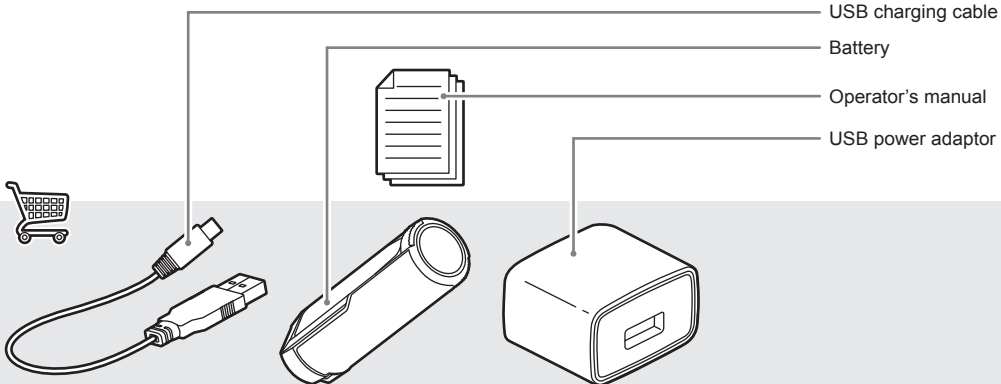
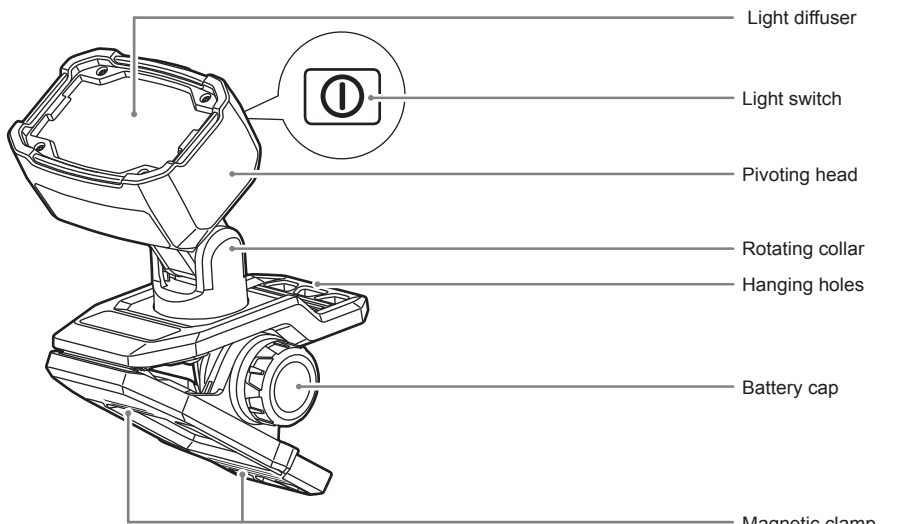

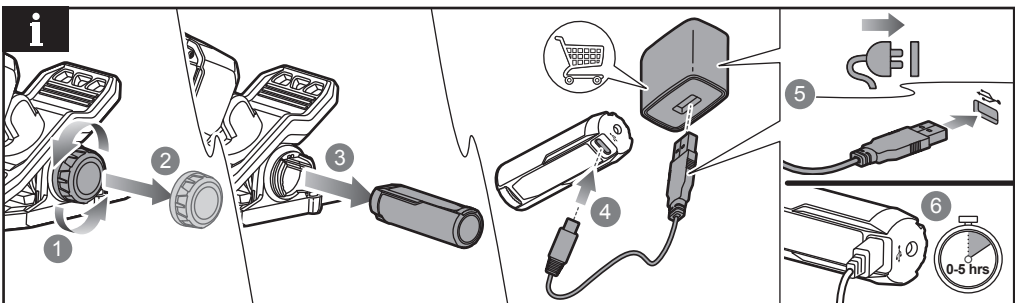
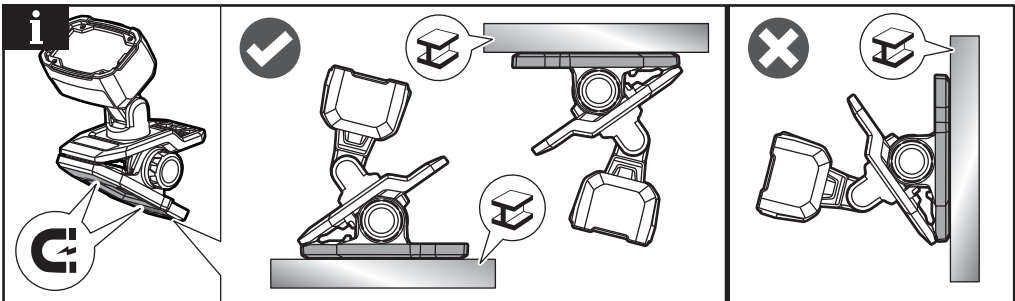
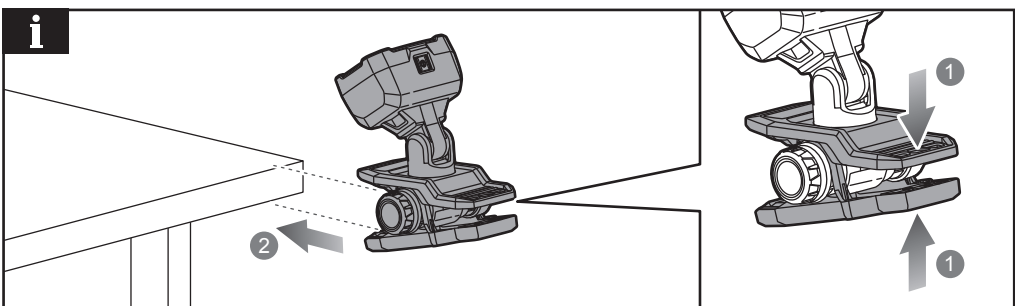
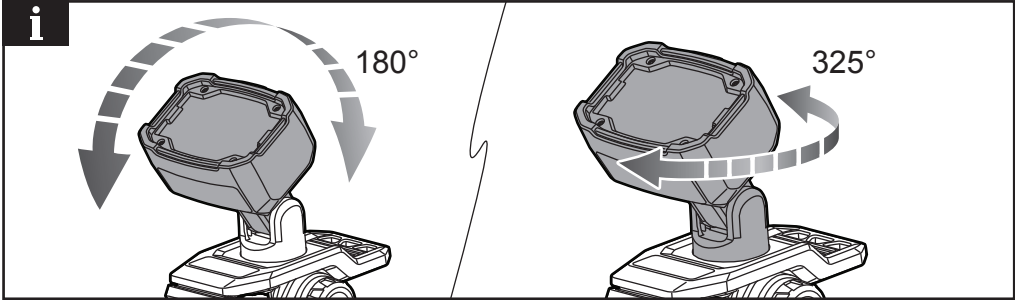
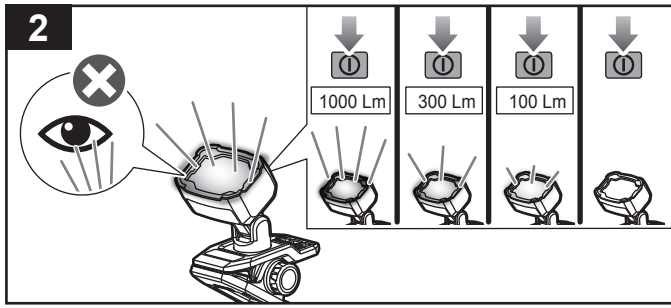
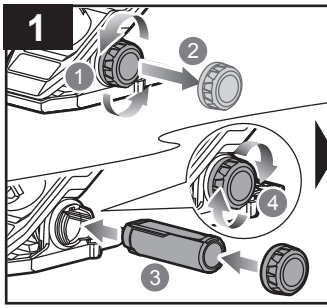

PRODUCT SPECIFICATIONS

USB Lithium Magnetic Clamp Light	
Model	RMCL4
Voltage	4 V
Wattage	12 W
Light output (Lumens)	
High brightness level	1000 Lm
Medium brightness level	300 Lm
Low brightness level	100 Lm
Colour rendering index (CRI)	80
Correlated colour temperature (CCT)	5000 K
Maximum clamping force	36 N
Maximum clamping capacity	50 mm
IP rating	IP54
Weight - excluding battery pack	0.29 kg

BATTERY

Compatible battery pack RB420
RB4L20
RB4L30

Imported by:
Techtronic Industries Australia Pty Ltd
31 Gilby Road, Mount Waverley, VIC 3149
Melbourne, Australia

Techtronic Industries N.Z. Limited
Unit C, 70 Business Parade South,
Highbrook, Auckland 2013, New Zealand