

AEG

BHO18B

Original instructions

Important!

It is essential that you read the instructions in this manual before assembling, operating and maintaining the product.

Subject to technical modifications.

1. Handle, insulated gripping surface
2. Lock-off button
3. Trigger
4. Dust port
5. Depth adjustment knob
6. Depth scale
7. Hex key

8. Aux fence knob
9. Side fence
10. Battery port
11. Dust flow direction knob
12. V-shape notch
13. Blade
14. Kickstand

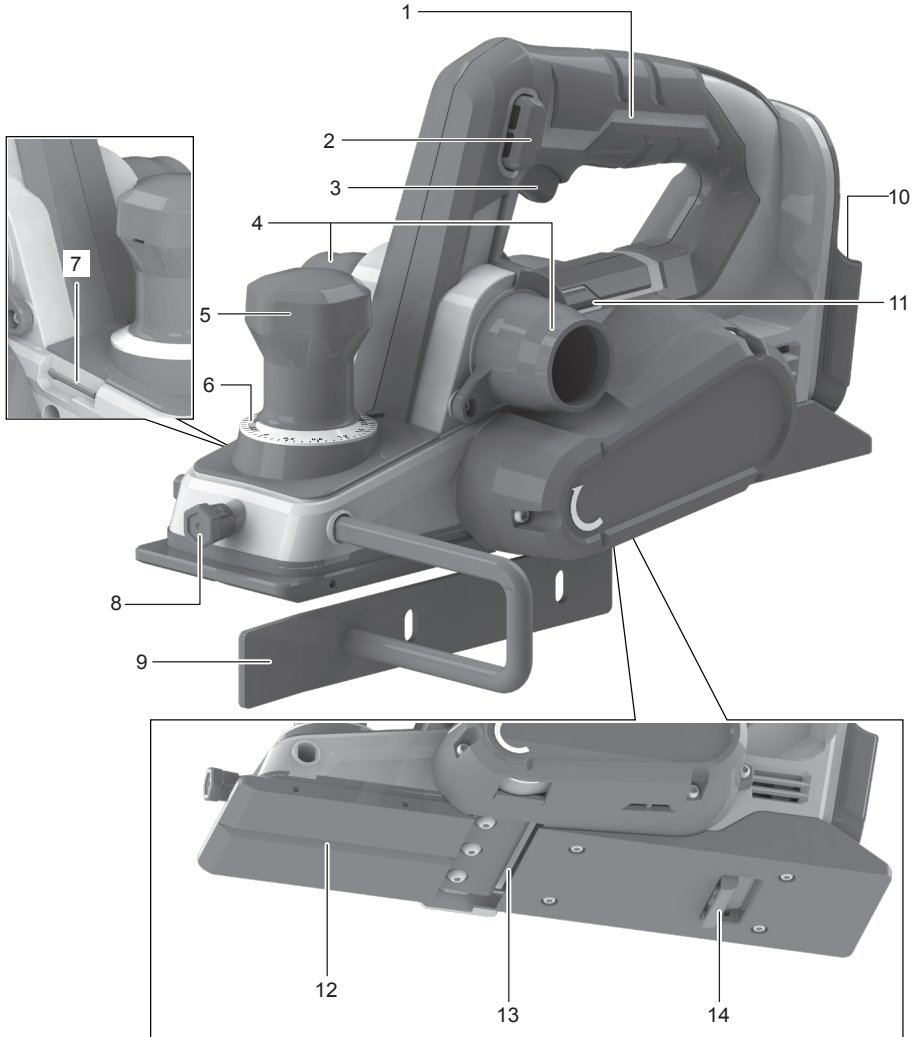

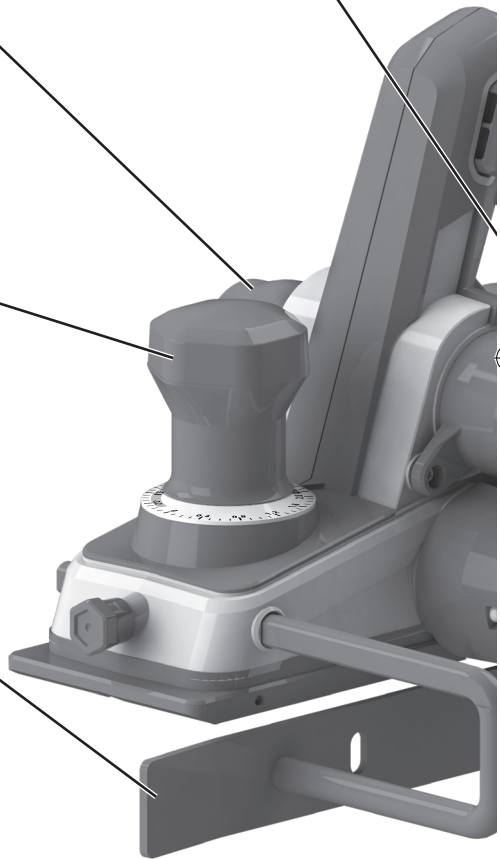
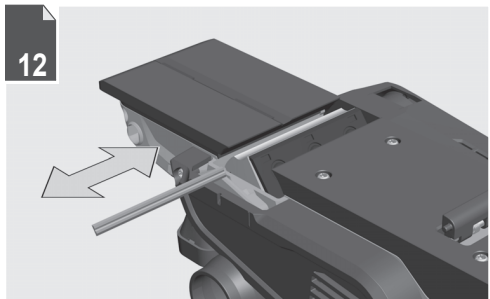
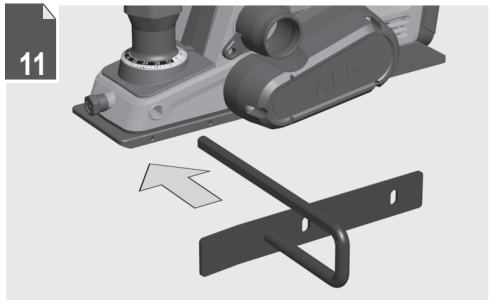
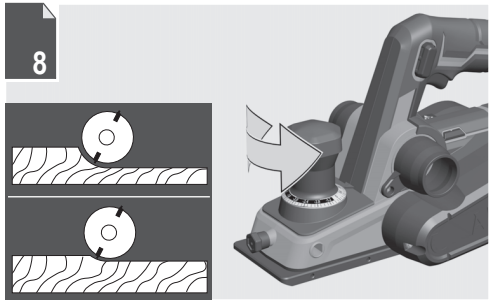
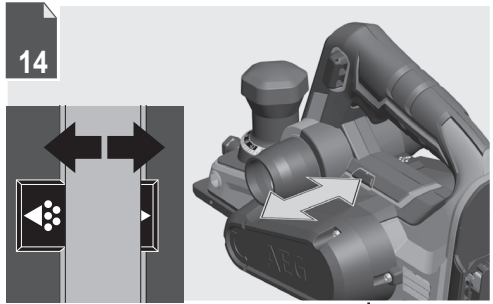
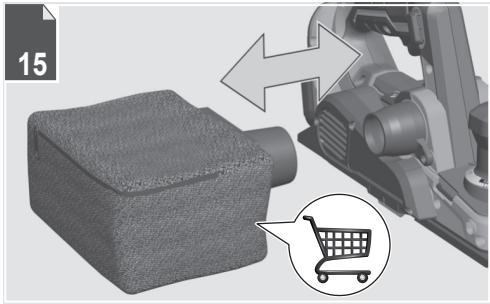

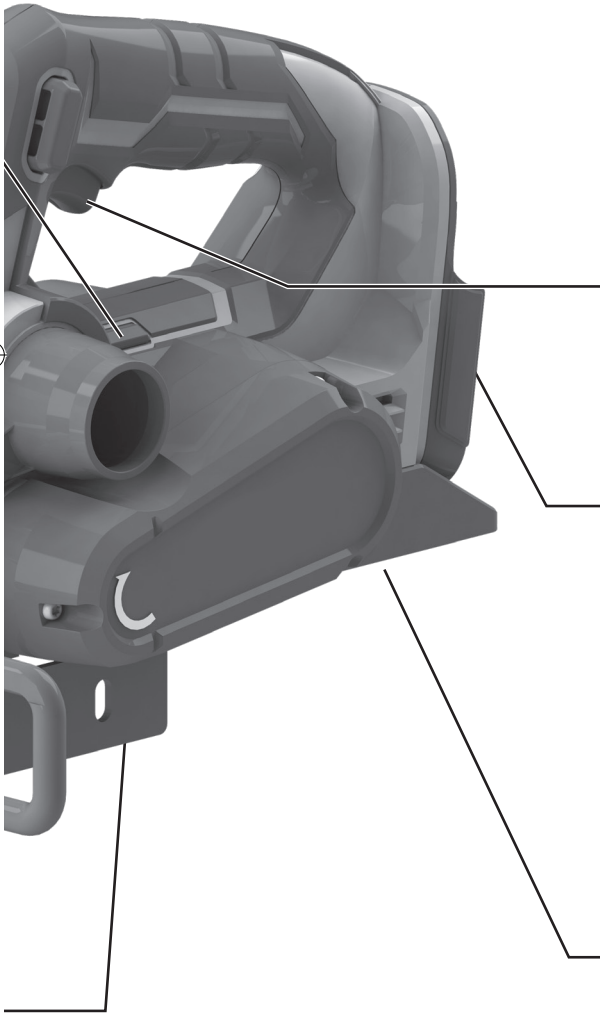
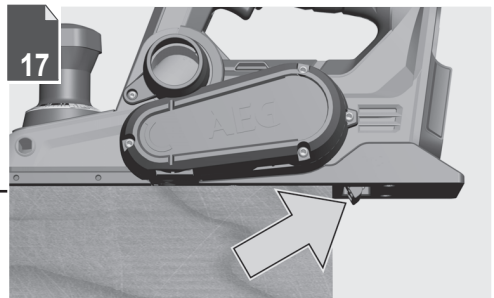
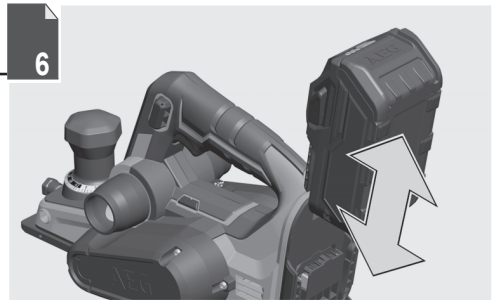
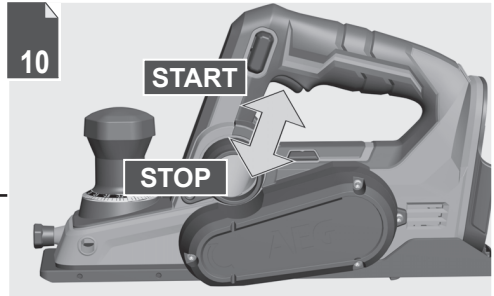
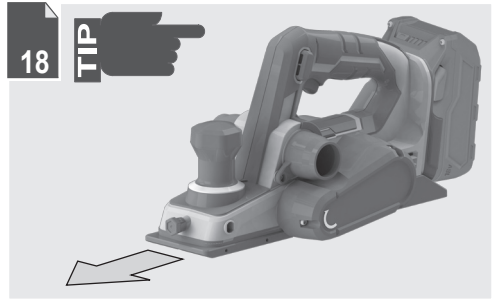
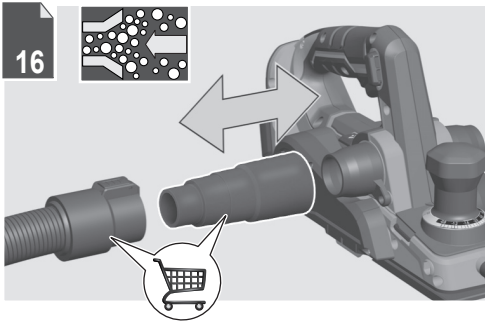

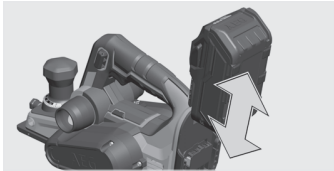

Remove the battery pack before starting any work on the machine.

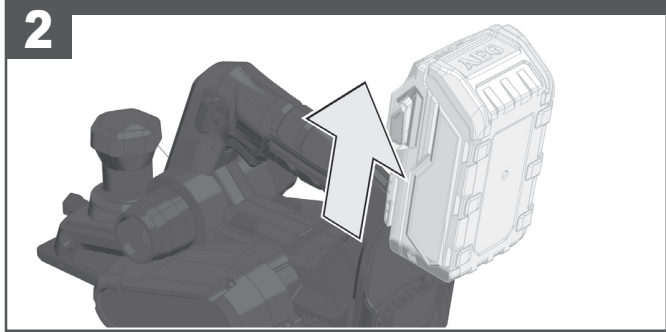
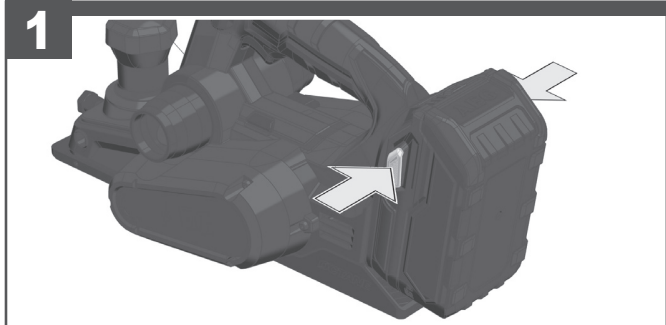
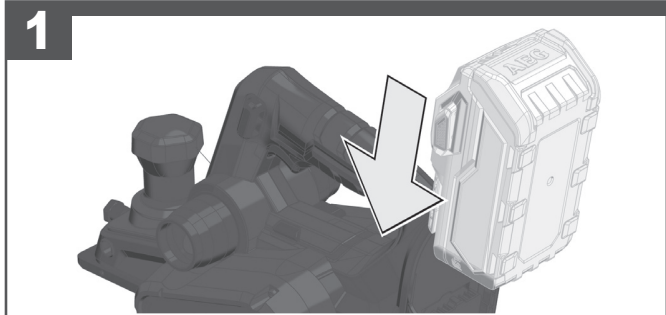

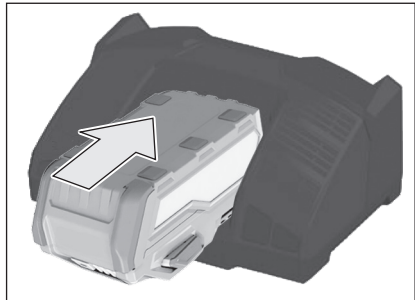
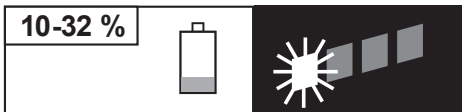
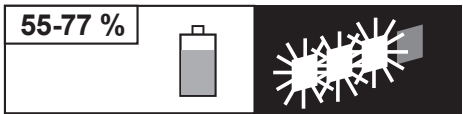
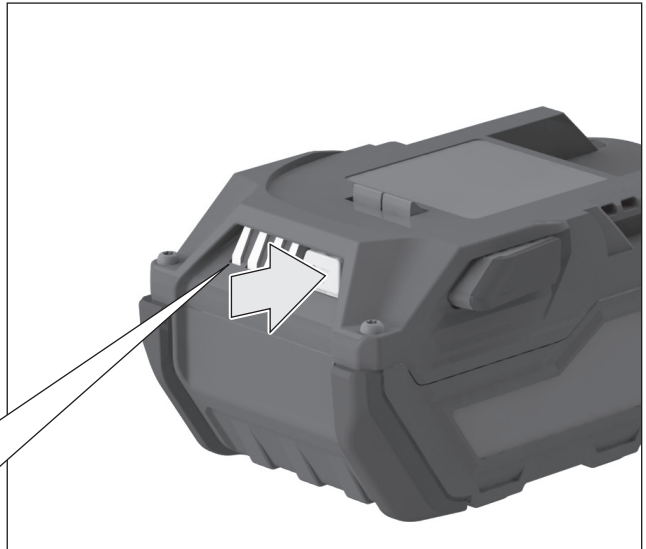

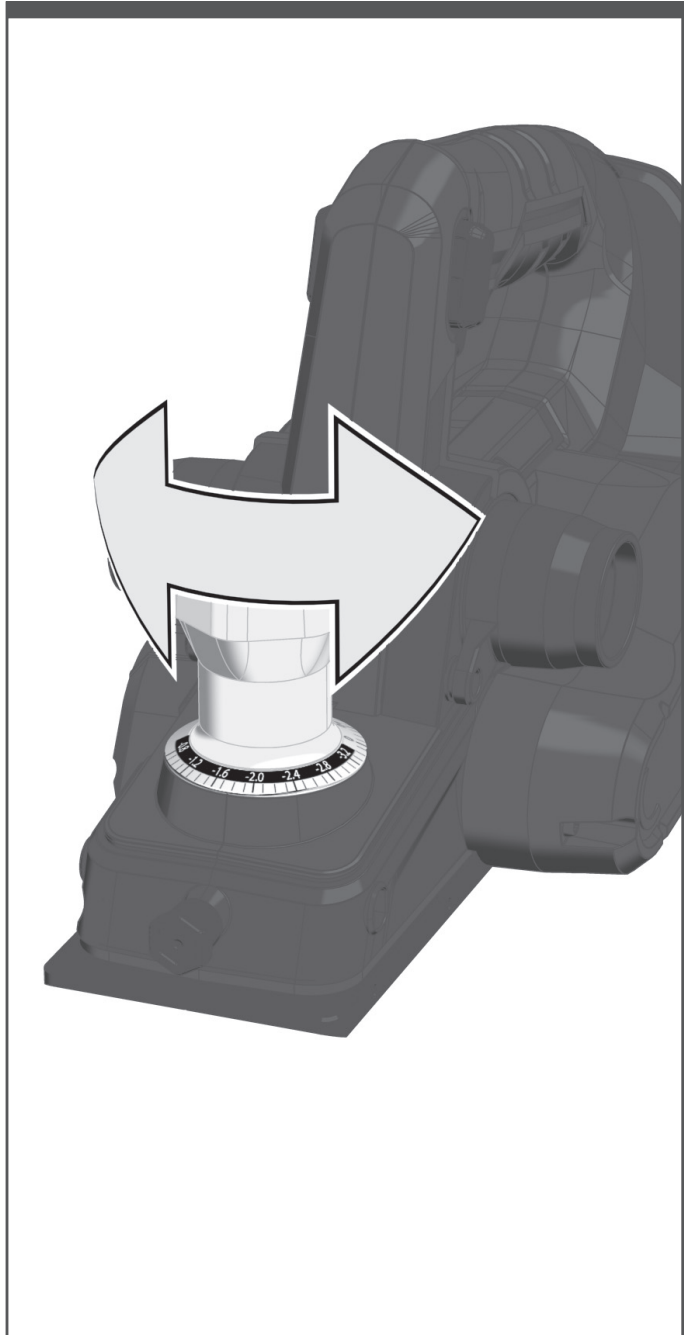
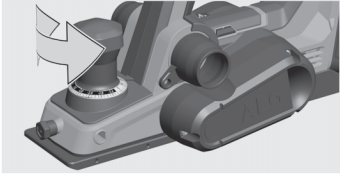

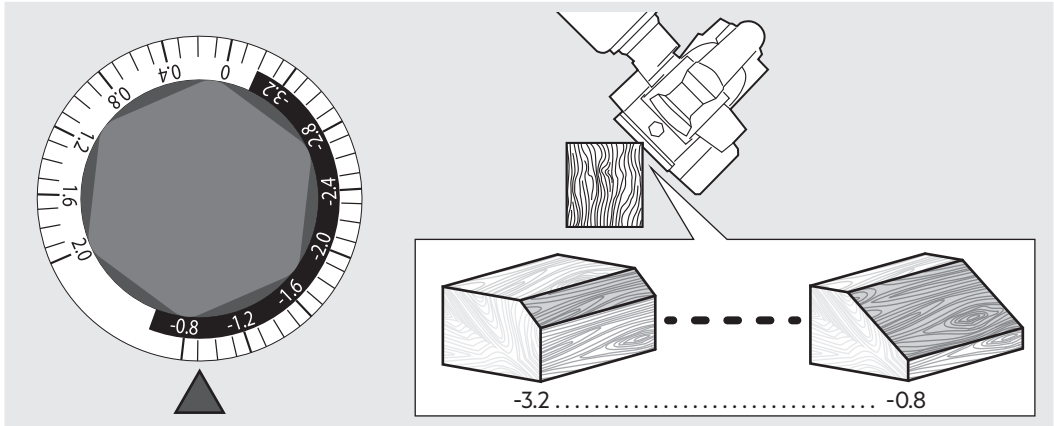
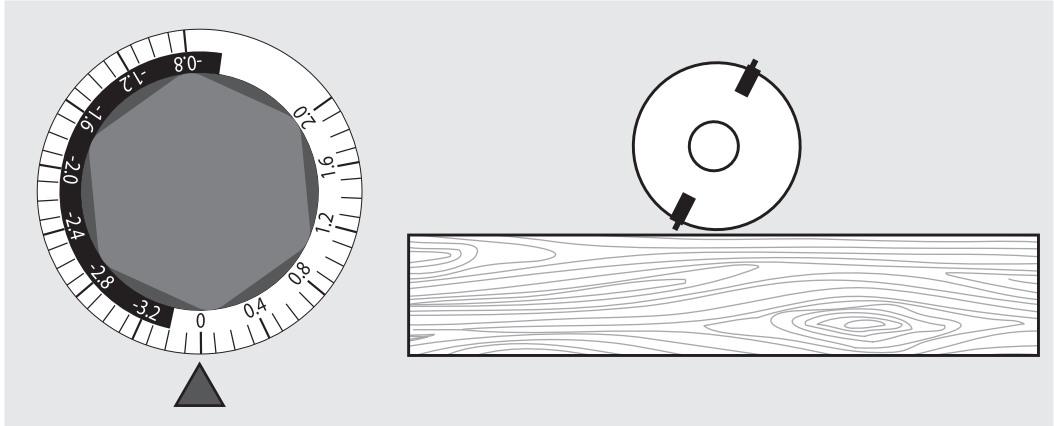
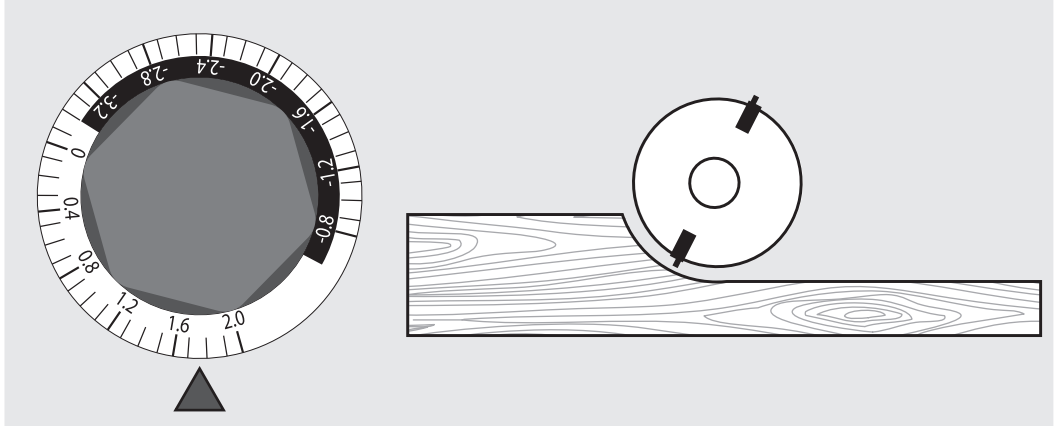

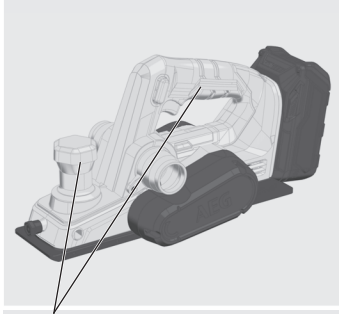
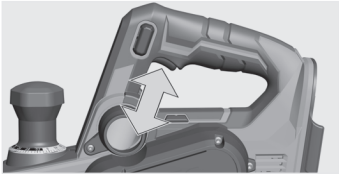

Insulated gripping surface

START

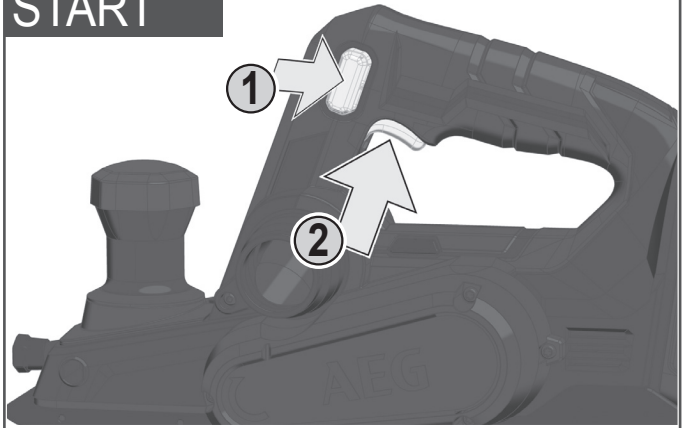

STOP

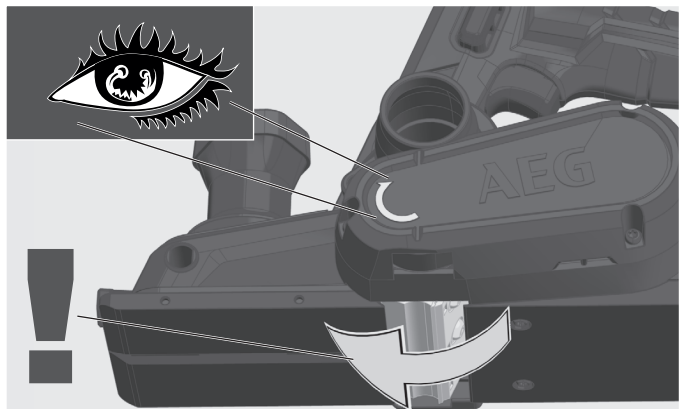
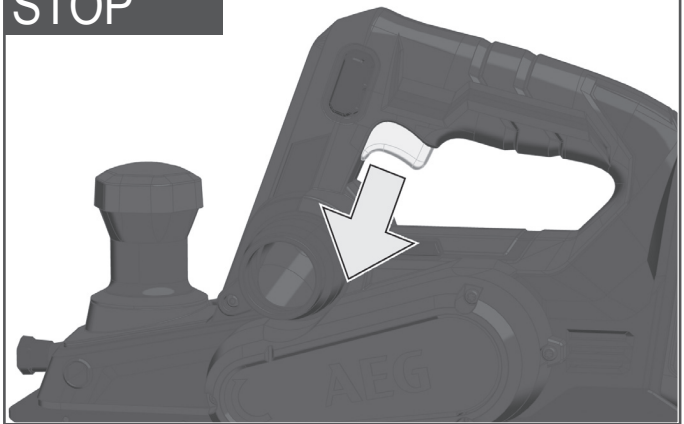

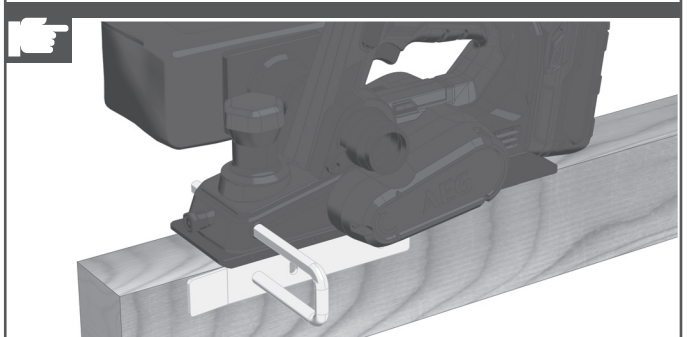
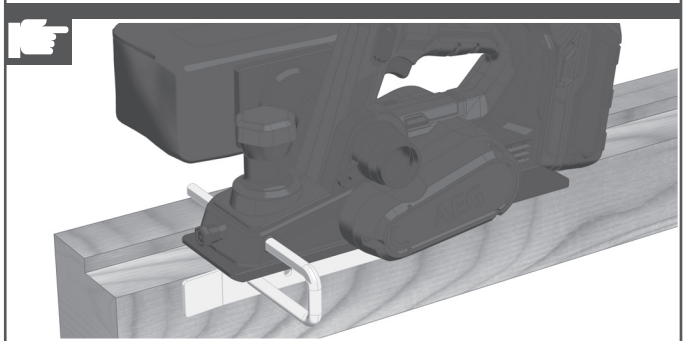
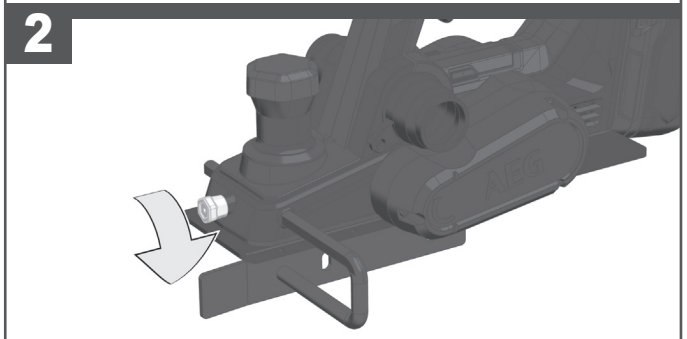
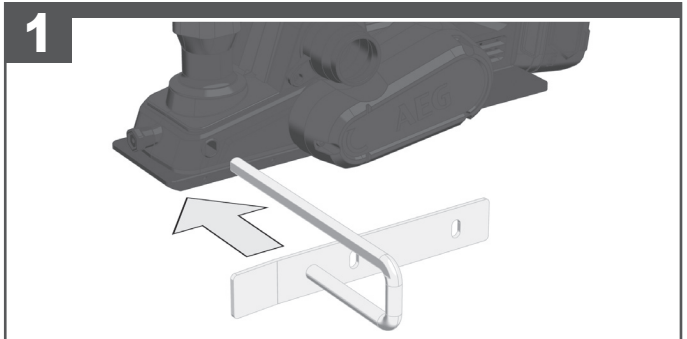
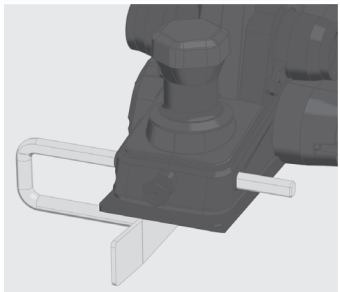
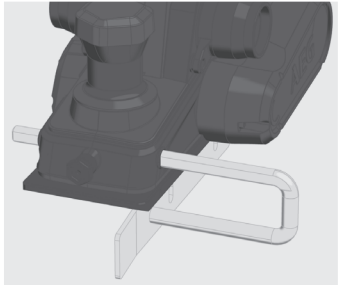
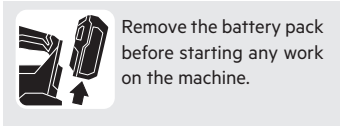
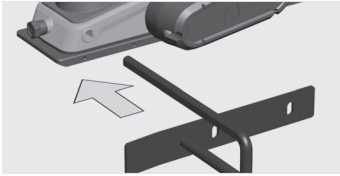

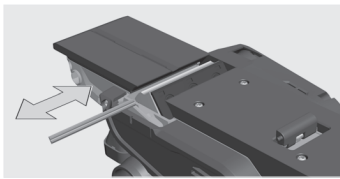

 Remove the battery pack before starting any work on the machine.

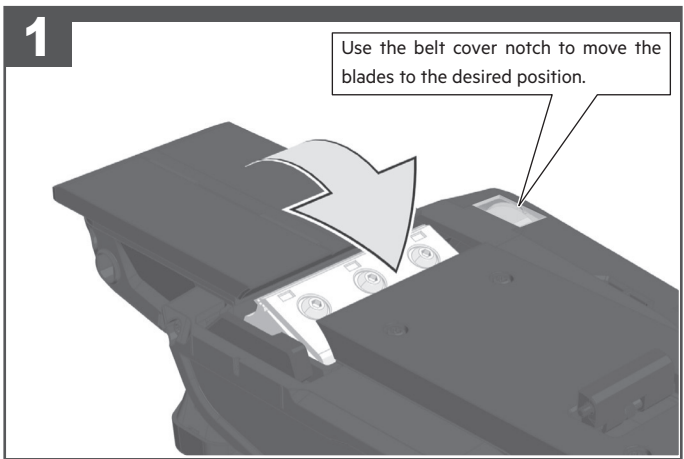

Max 1 x 

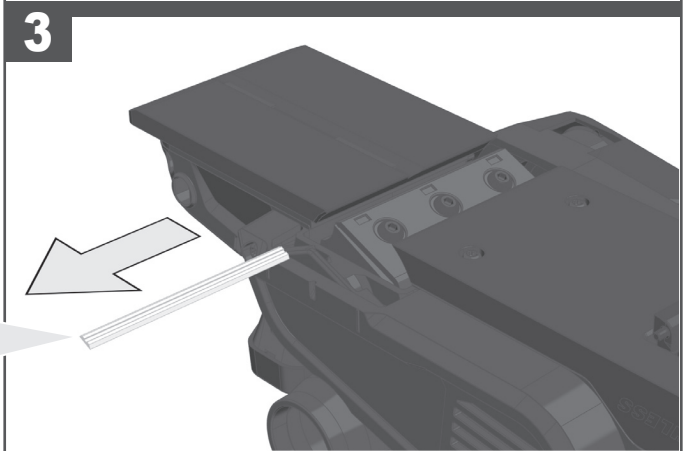
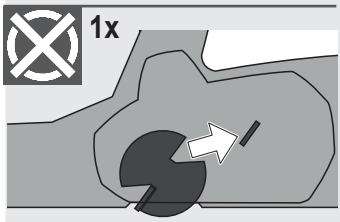
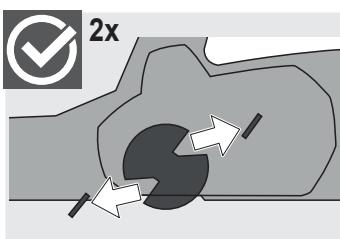
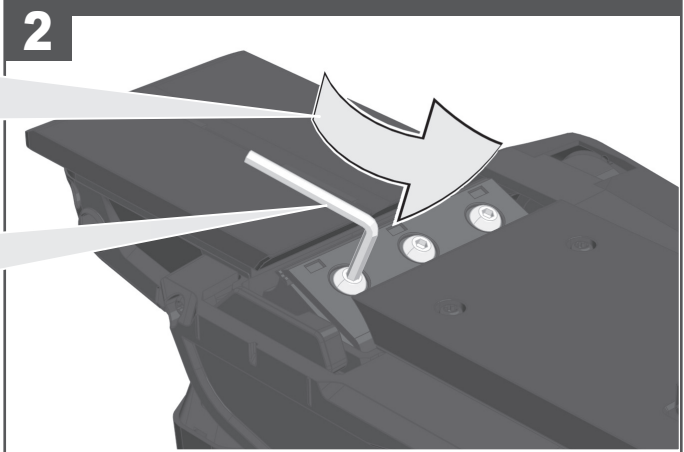
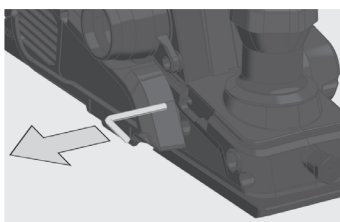

4

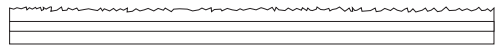

180°

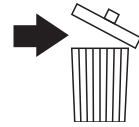
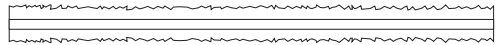
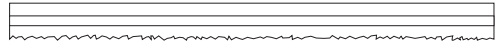

5

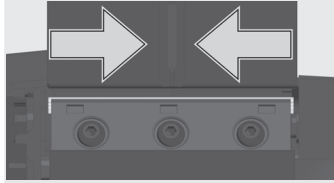
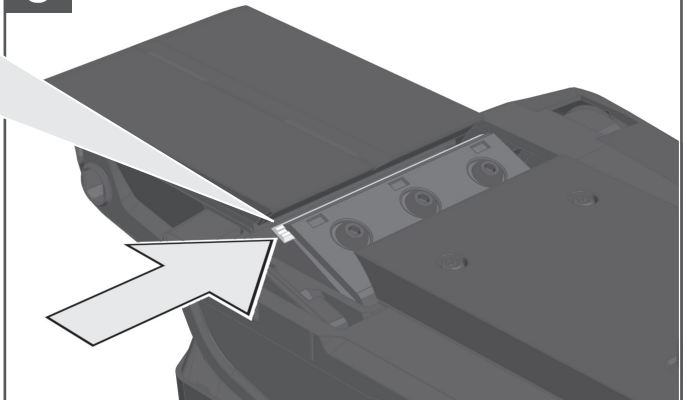

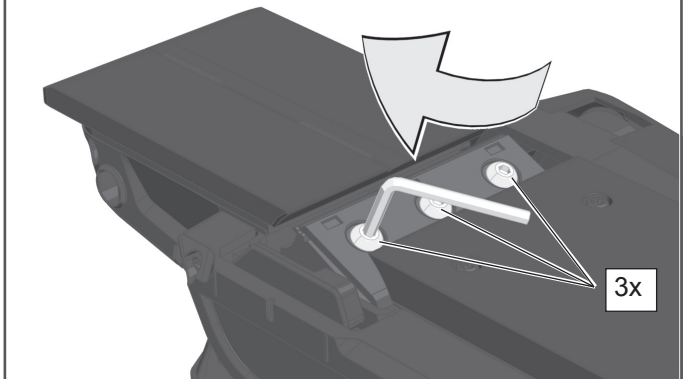

6

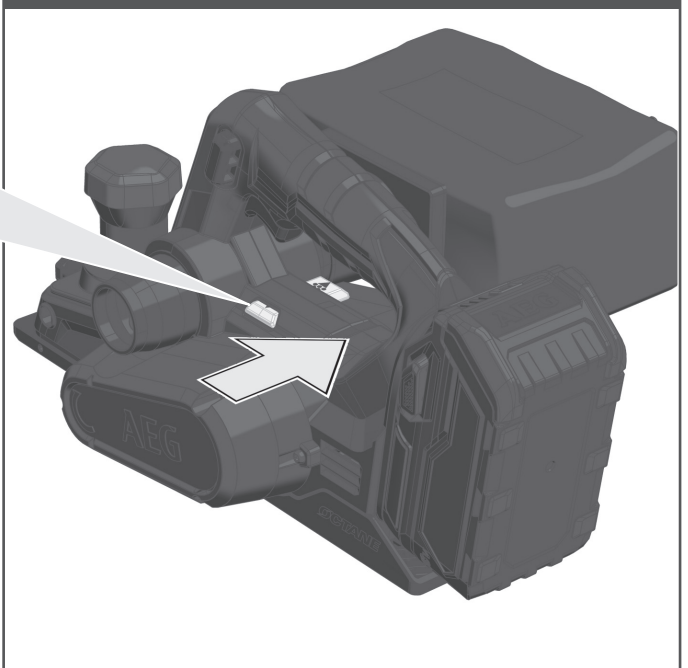
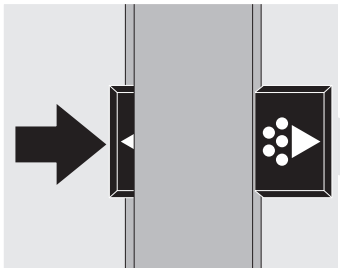
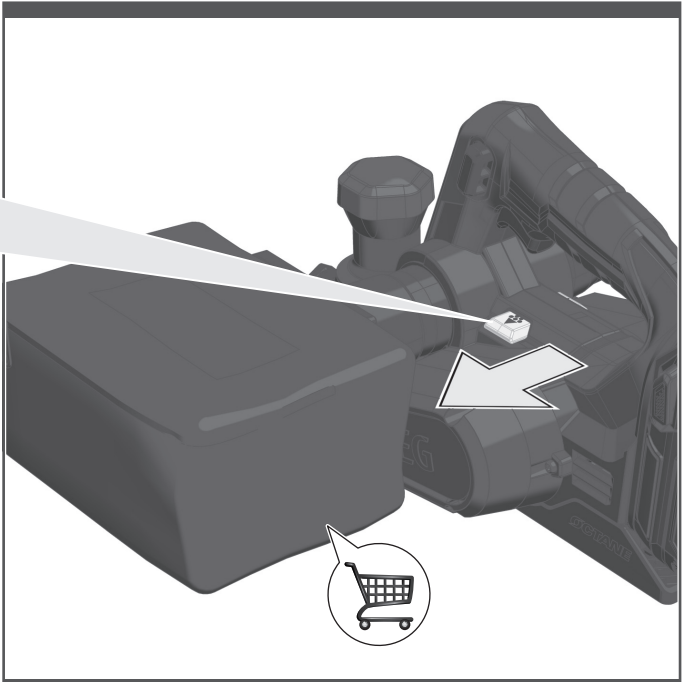
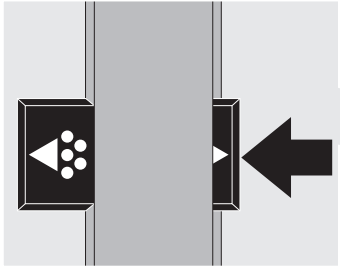
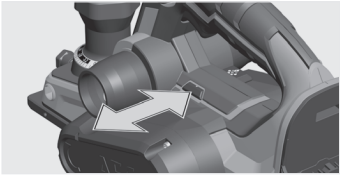

3x

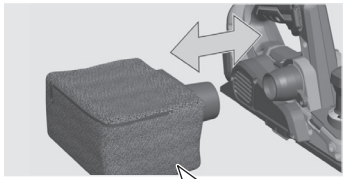



 Remove the battery pack before starting any work on the machine.

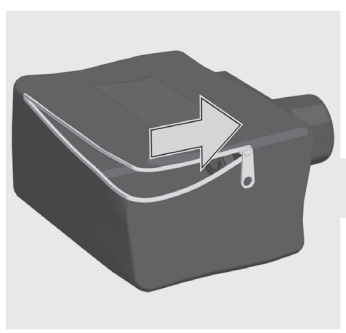
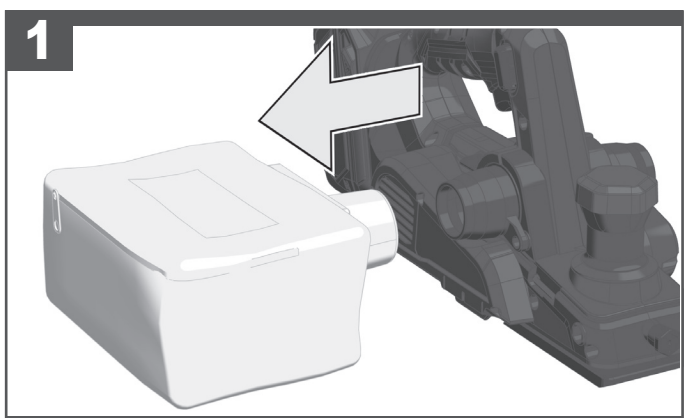
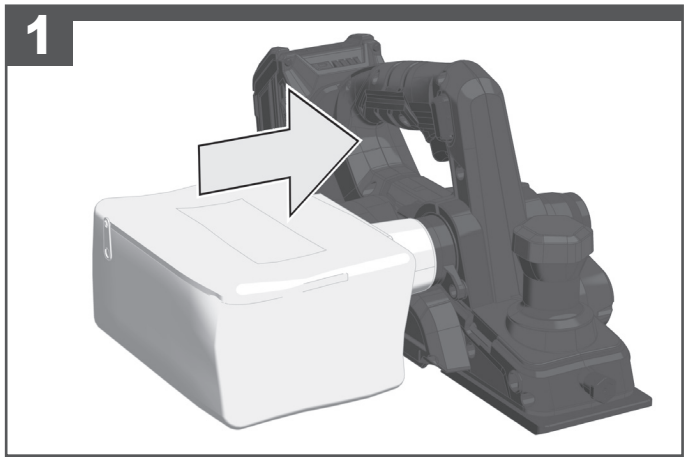

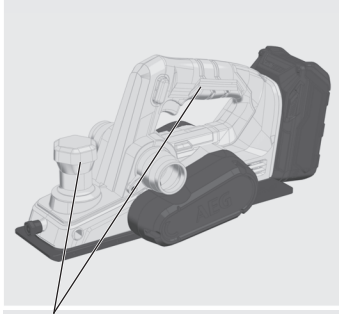
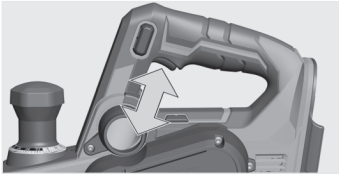

Insulated gripping surface

START

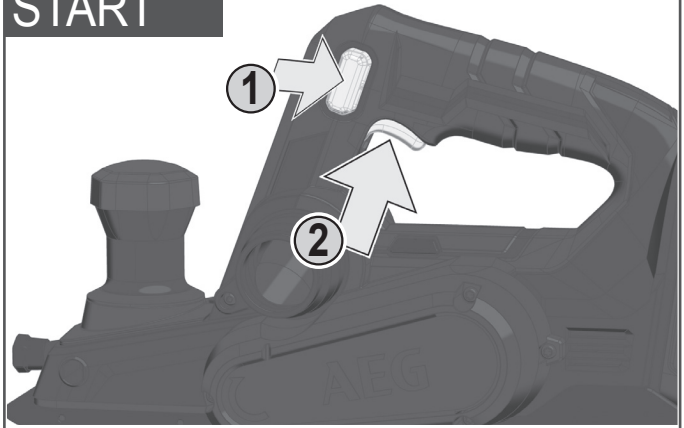

STOP

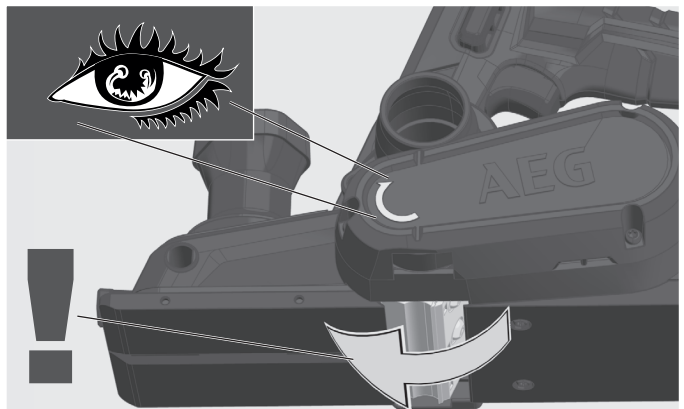
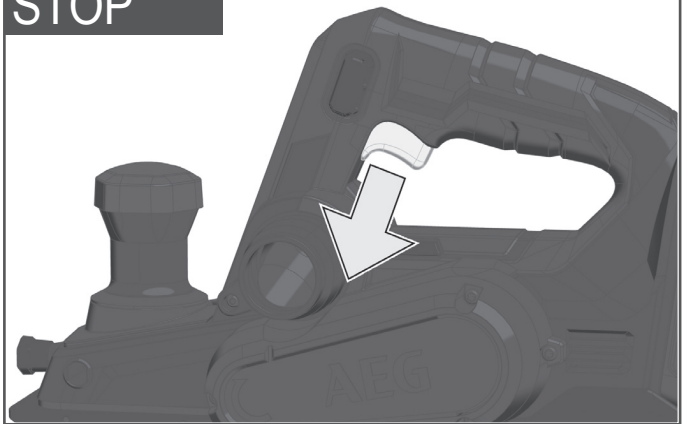

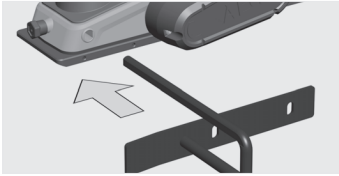

Remove the battery pack before starting any work on the machine.

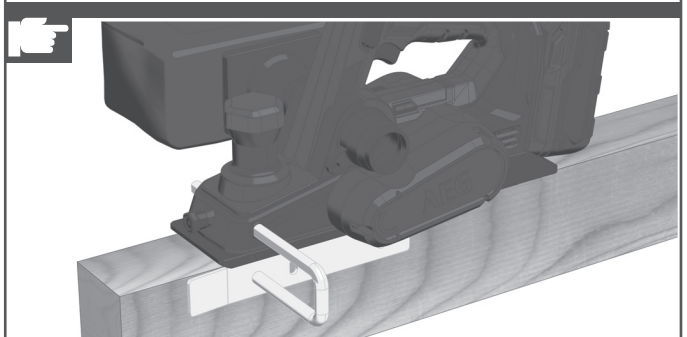
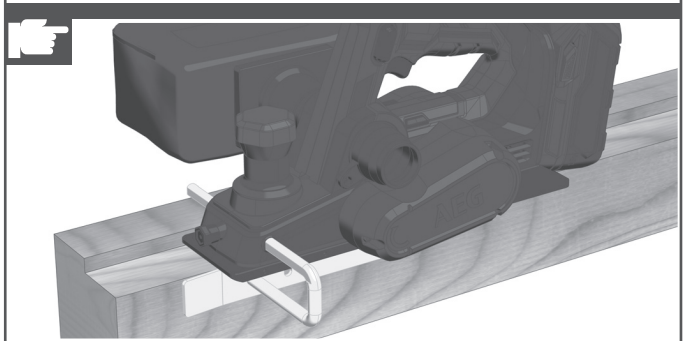
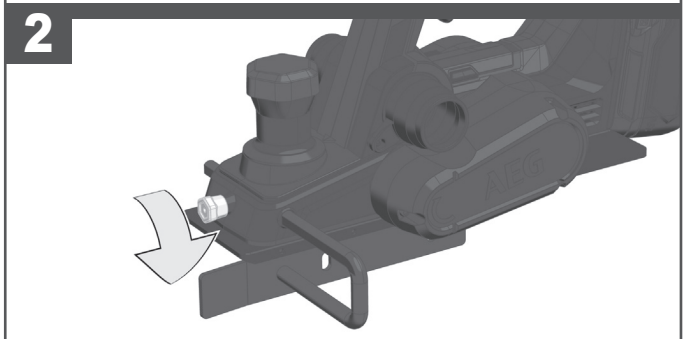
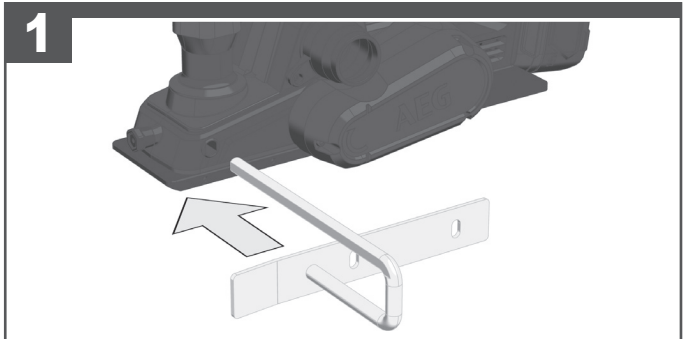
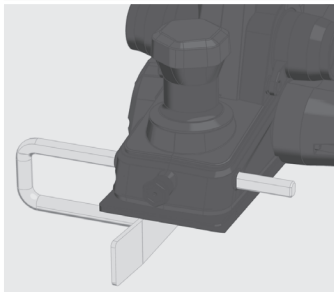
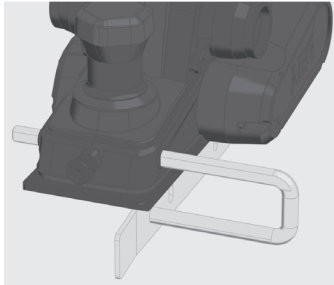

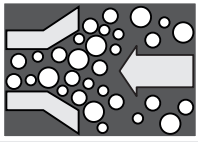

Remove the battery pack before starting any work on the machine.

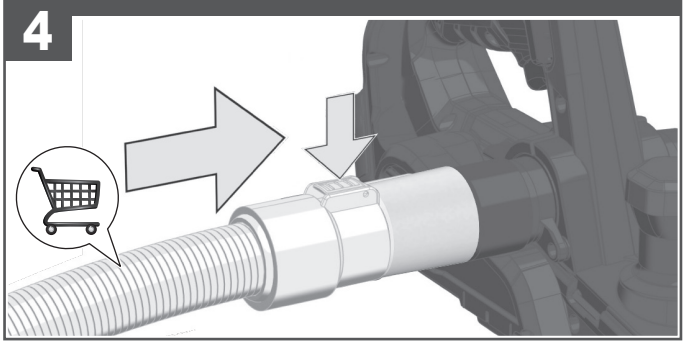
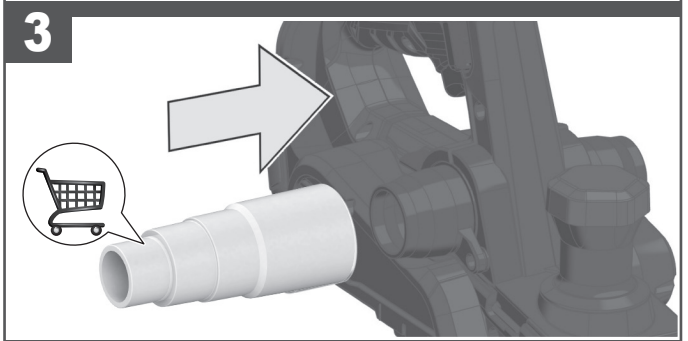
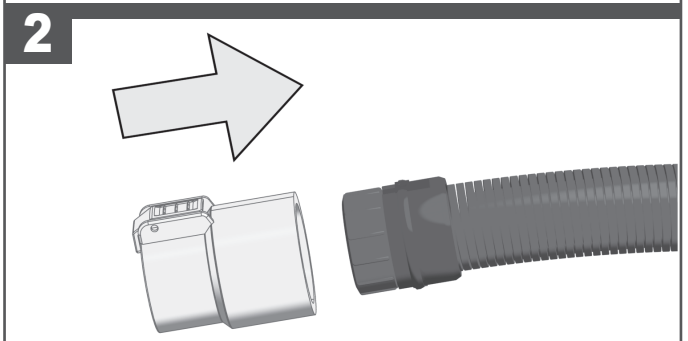
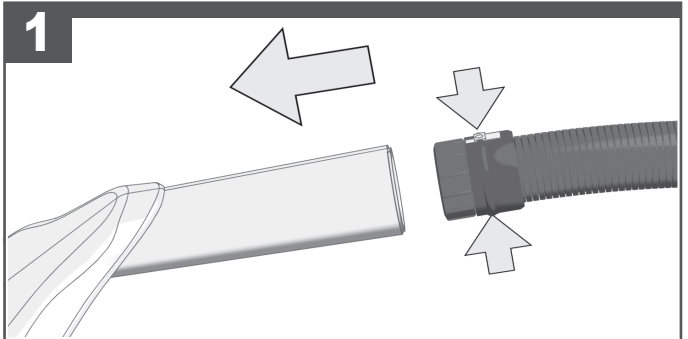

AP218E

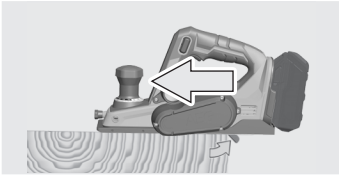

Push in the kick stand and slide to lock in the retracted position.

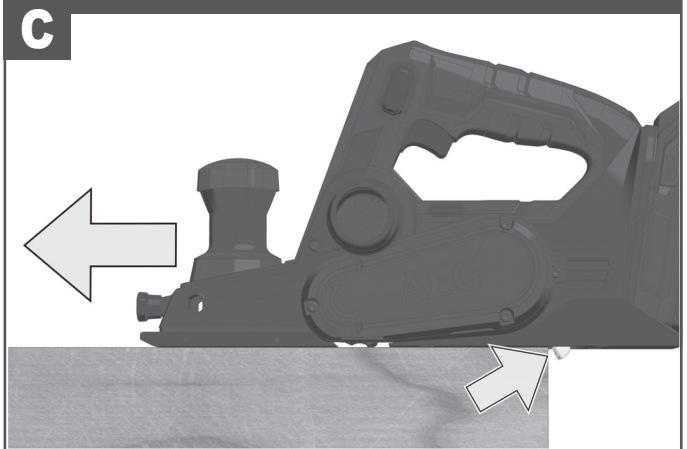
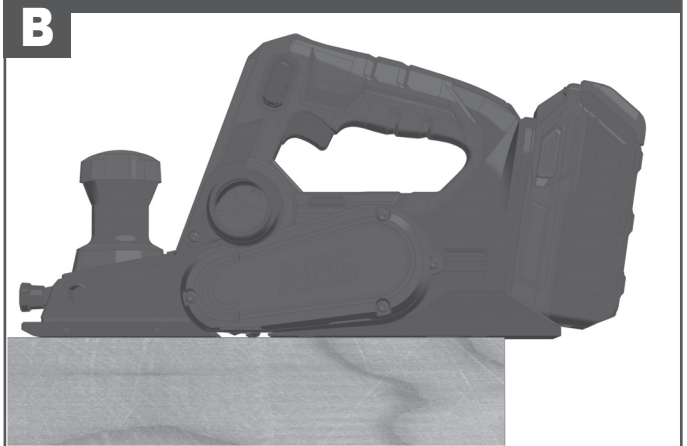
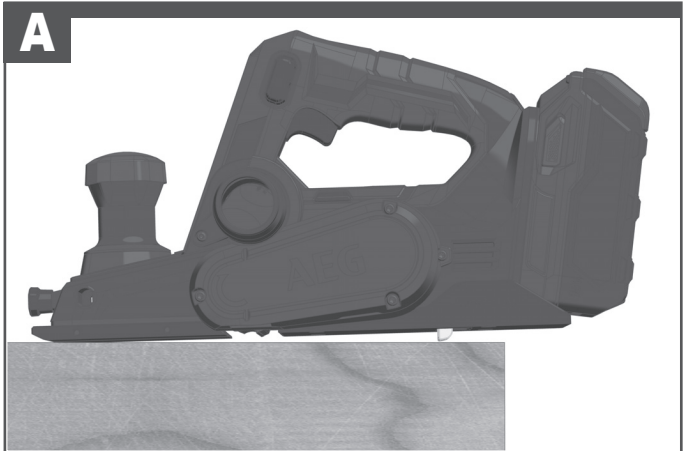
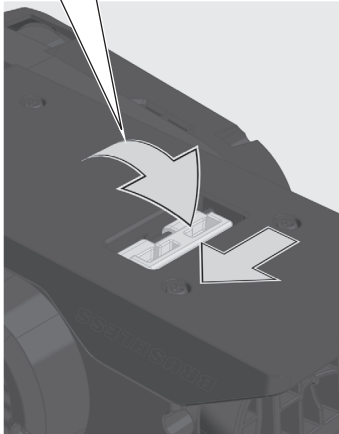

i TIP 

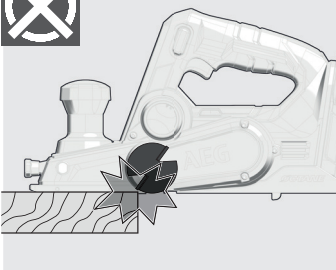
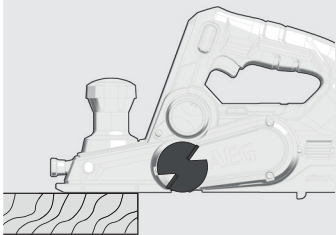

1

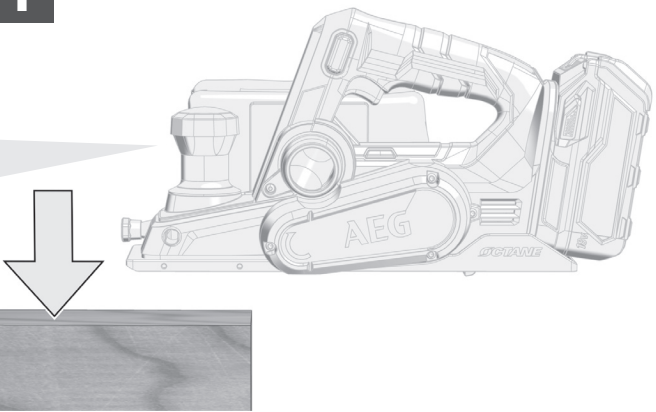

2

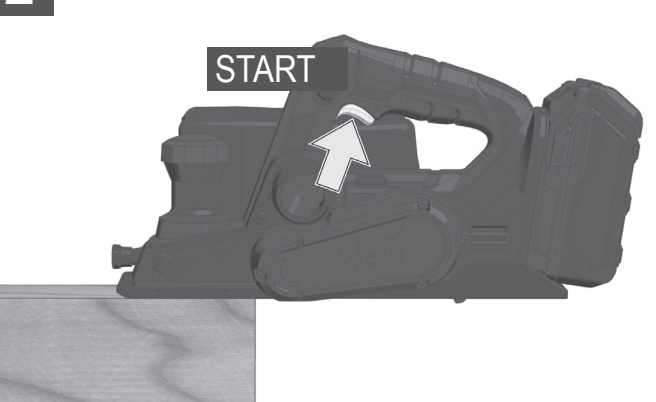

3

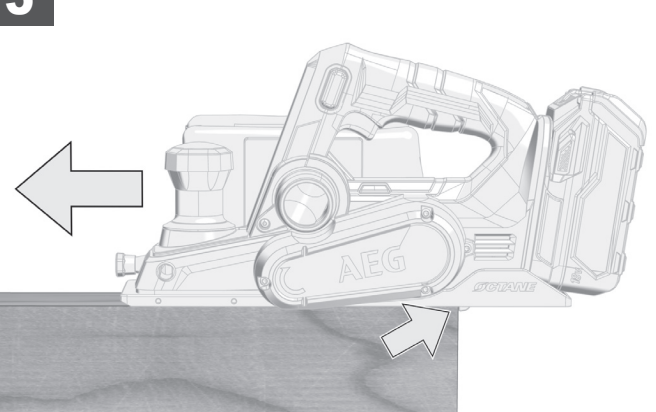

4

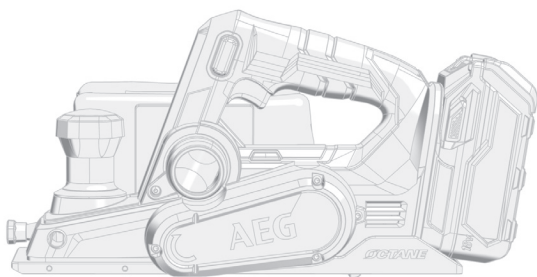

5

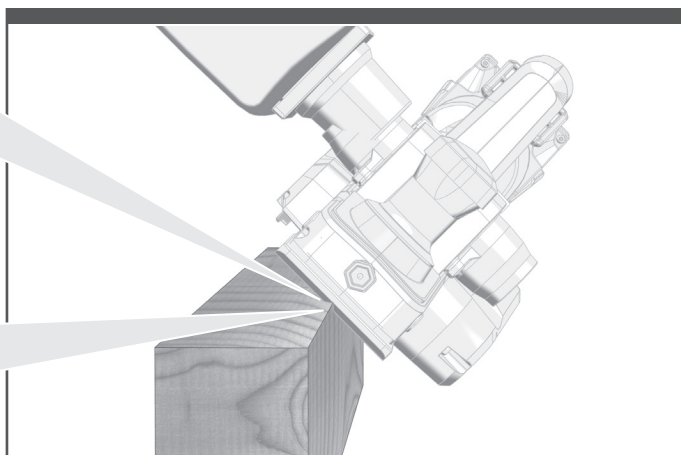
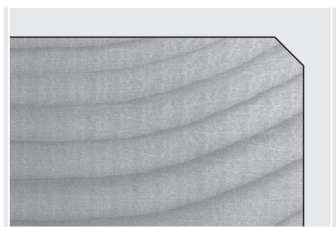
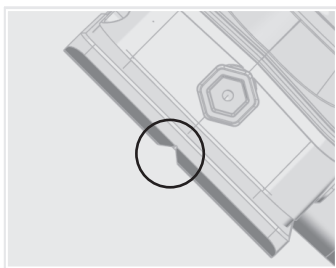

**TECHNICAL DATA****PLANER****BHO18B**

Rated voltage	18 V $\overline{\text{---}}$
Planing width	82 mm
Planing depth max	2.0 mm
Rabbet depth	12.5 mm
No-load speed	14300 min ⁻¹
Weight - not including battery pack	2.6 kg
Measured values determined according to EN 62841:	
A-weighted sound pressure level	$L_p = 89.5 \text{ dB(A)}$
Uncertainty K	3 dB(A)
A-weighted sound power level	$L_w = 100.5 \text{ dB(A)}$
Uncertainty K	3 dB(A)
Wear ear protectors.	
The vibration total values (triaxial vector sum) determined according to EN 62841:	
Vibration emission value	$a_n = 3.4 \text{ m/s}^2$
Uncertainty K	1.5 m/s ²

⚠ WARNING

The vibration emission level given in this information sheet has been measured in accordance with a standardised test given in EN 62841 and may be used to compare one tool with another. It may be used for a preliminary assessment of exposure. The declared vibration emission level represents the main applications of the tool. However if the tool is used for different applications, with different accessories or poorly maintained, the vibration emission may differ. This may significantly increase the exposure level over the total working period.

An estimation of the level of exposure to vibration should also take into account the times when the tool is switched off or when it is running but not actually doing the job. This may significantly reduce the exposure level over the total working period.

Identify additional safety measures to protect the operator from the effects of vibration such as: maintain the tool and the accessories, keep the hands warm, organisation of work patterns.

BATTERY AND CHARGER

Compatible battery pack (not included)	Compatible charger (not included)
L1815R	
L1820R	AL18G
L1825R	AL1218G
L1830R-X5	BL1218
L1840R	BLK1218
L1850R	BL18DP-X5
L1860R	BL18DP2-X5
L1860R-X5	BL18DPS
L1890R	

Use AEG 18V battery and charger only

⚠ WARNING! Read all safety warnings, instructions, illustrations and specifications provided with this power tool. Failure to follow all instructions listed below may result in electric shock, fire and/or serious injury. **Save all warnings and instructions for future reference.**

PLANER SAFETY WARNINGS

Wait for the cutter to stop before setting the tool down. An exposed rotating cutter may engage the surface leading to possible loss of control and serious injury.

Use clamps or another practical way to secure and support the workpiece to a stable platform. Holding the workpiece by your hand or against the body leaves it unstable and may lead to loss of control.

Remove the battery pack before starting any work on the machine.

Do not dispose of used battery packs in the household refuse or by burning them. AEG Distributors offer to retrieve old batteries to protect our environment.

Do not store the battery pack together with metal objects (short circuit risk).

Use only System AEG chargers for charging System AEG battery packs. Do not use battery packs from other systems.

Battery acid may leak from damaged batteries under extreme load or extreme temperatures. In case of contact with battery acid wash it off immediately with soap and water. In case of eye contact rinse thoroughly for at least 10 minutes and immediately seek medical attention.

ADDITIONAL SAFETY WARNINGS

Ambient temperature range for tool during operation is between 0°C and 40°C.

Ambient temperature range for tool storage is between 0°C and 40°C.

The recommended ambient temperature range for the charging system during charging is between 10°C and 38°C.

RESIDUAL RISKS

Even when the product is used as prescribed, it is still impossible to completely eliminate certain residual risk factors. The operator should pay particular and additional attention to these points in order to reduce the risk of serious personal injury.

- Injury to hearing – Wear suitable ear protection and limit exposure.
- Injury to sight – Wear protective eye shields or goggles when using the product.
- Injury caused by vibration – Limit exposure and follow the instructions on risk reduction in this manual.
- Electric shock after contact with hidden wires – Hold the product only by insulated surfaces.
- Injury caused by dust – Dust created by operating the product can cause respiratory injury. Wear appropriate dust control mask with filters suitable for protecting against particles from the material being worked on.





RISK REDUCTION

It has been reported that vibrations from hand-held tools may contribute to a condition called Raynaud's Syndrome in certain individuals. Symptoms may include tingling, numbness and blanching of the fingers, usually apparent upon exposure to cold. Hereditary factors, exposure to cold and dampness, diet, smoking and work practices are all thought to contribute to the development of these symptoms. There are measures that can be taken by the operator to possibly reduce the effects of vibration:

- Keep your body warm in cold weather. When operating the unit wear gloves to keep the hands and wrists warm. It is reported that cold weather is a major factor contributing to Raynaud's Syndrome.
- After each period of operation, exercise to increase blood circulation.
- Take frequent work breaks. Limit the amount of exposure per day.

If you experience any of the symptoms of this condition, immediately discontinue use and see your doctor about these symptoms.

⚠ WARNING! Injuries may be caused, or aggravated, by prolonged use of a tool. When using any tool for prolonged periods, ensure you take regular breaks.

SPECIFIED CONDITIONS OF USE

The planer is intended for planing wood (removing an even layer to provide a smooth, flat finish) and rebating wood.

Do not use the product for any other purpose.

BATTERIES

Battery packs which have not been used for some time should be recharged before use.

Temperatures in excess of 50°C (122°F) reduce the performance of the battery pack. Avoid extended exposure to heat or sunshine (risk of overheating).

The contacts of chargers and battery packs must be kept clean.

For an optimum life-time, the battery packs have to be fully charged, after used.

To obtain the longest possible battery life remove the battery pack from the charger once it is fully charged.

For battery pack storage longer than 30 days:

- Store the battery pack where the temperature is below 27°C and away from moisture.
- Store the battery packs in a 30% - 50% charged condition.
- Every six months of storage, charge the pack as normal.

ADDITIONAL BATTERY SAFETY WARNINGS

⚠ WARNING! To reduce the risk of fire, personal injury, and product damage due to a short circuit, never immerse your tool, battery pack or charger in fluid or allow a fluid to flow inside them. Corrosive or conductive fluids, such as seawater, certain industrial chemicals, and bleach or bleach containing products, etc., can cause a short circuit.

Ambient temperature range for battery during use is between 0°C and 40°C.

Ambient temperature range for battery storage is between 0°C and 27°C.

TRANSPORTING LITHIUM BATTERIES

Lithium-ion batteries are subject to the Dangerous Goods Legislation requirements.

Transportation of those batteries has to be done in accordance with local, national and international provisions and regulations.

- The user can transport the batteries by road without further requirements.
- Commercial transport of lithium-ion batteries by third parties is subject to Dangerous Goods regulations. Transport preparation and transport are exclusively to be carried out by appropriately trained persons and the

process has to be accompanied by corresponding experts.

When transporting batteries:

- Ensure that battery contact terminals are protected and insulated to prevent short circuit.
- Ensure that battery pack is secured against movement within packaging.
- Do not transport batteries that are cracked or leak.

Check with forwarding company for further advice.

BATTERY PACK PROTECTION

The battery pack has overload protection that protects it from being overloaded and helps to ensure long life. Under extreme stress the battery electronics switch off the machine automatically. To restart, switch the machine off and then on again. If the machine does not start up again, the battery pack may have discharged completely. In this case it must be recharged in the battery charger.

THERMAL OVERLOAD PROTECTION

Overheated cells will reduce performance, run time and life. Overheating can occur from battery packs being exposed to very hot environments or from the tool they are powering being over-worked. The control electronics will automatically shut down the battery pack to protect the cells which in turn protects the electronics and motor within the tool. The battery pack will automatically shut itself down again should the temperature condition remain high when the trigger is pulled again. The system will continue to shut the battery pack down until the temperature is returned to a safe operating level.

CURRENT OVERLOAD PROTECTION

The control electronics will instantly shut down the battery back when excessive current draw is detected - protecting both the battery cells and the motor of the tool. Releasing the trigger will reset the battery pack each time.

INDIVIDUAL CELL MONITORING

The control electronics constantly check each individual cell and automatically adjust its charge and discharge requirements accordingly.

This system maximises individual cell life whilst ensuring that the battery pack is delivering peak performance to the tool at all times.

MAINTENANCE

The ventilation slots of the machine must be kept clear at all times.

Use only AEG accessories and AEG spare parts. Should components need to be replaced which have not been described, please contact one of our AEG service agents (see our list of guarantee/service addresses).

If needed, an exploded view of the tool can be ordered. Please state the Article No. as well as the machine type printed on the label and order the drawing at your local service agents or directly at:

Techtronic Industries Australia Pty Ltd

PO Box 1065
Mount Waverley VIC 3149
Tel. no. 1300 234 797
Australia

Techtronic Industries N.Z. Limited

PO Box 12-806
Penrose AUCKLAND 1642
Tel. no. 0800 234 797(0800 AEGPWR)
New Zealand



SYMBOLS



Safety alert

V

Volts



Direct current

min⁻¹

Revolutions or reciprocations per minute

n_0

No-load speed



Regulatory Compliance Mark (RCM). Product meets applicable regulatory requirements.



Please read the instructions carefully before starting the machine.



Do not dispose of electric tools together with household waste material. Electric tools and electronic equipment that have reached the end of their life must be collected separately and returned to an environmentally compatible recycling facility.







AEG

www.aegpowertools.com.au
www.aegpowertools.co.nz

Techtronic Industries Australia Pty Ltd

31 Gilby Road, Mount Waverley,
VIC, 3149, Australia

Techtronic Industries N.Z. Limited

Unit C, 70 Business Parade South,
Highbrook, Auckland 2013, New Zealand

961096519-01A

*AEG is a registered trademark used under
license from AB Electrolux (publ).*