

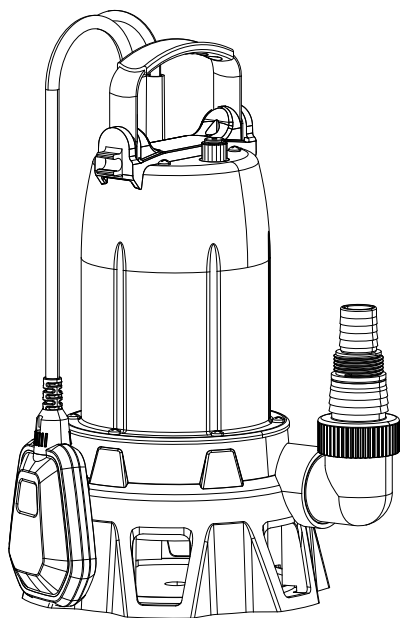

RSSS750 / RSSS1000

**750W/1000W STAINLESS STEEL
SUBMERSIBLE PUMP
OWNER'S OPERATING MANUAL**



RSSS750

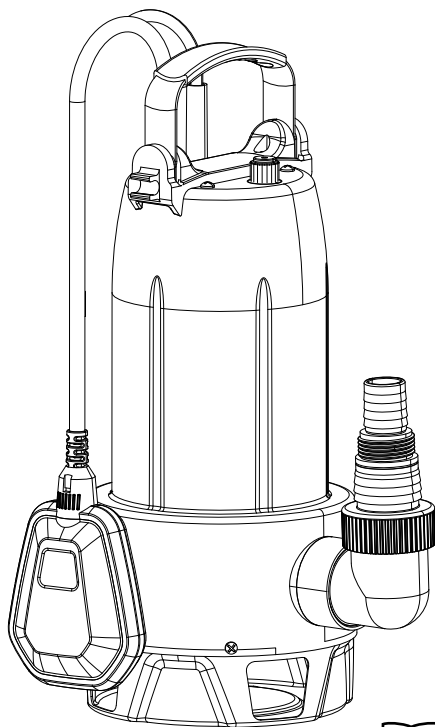

RSSS1000



DESCRIPTION

RSSS750 Components List

1. Water outlet
2. Pump base
3. Suction port
4. Floating switch
5. Cable of floating switch
6. Cable holder
7. Carry handle
8. Power cable
9. Pressure relief valve
10. Pump housing
11. Right angle adaptor

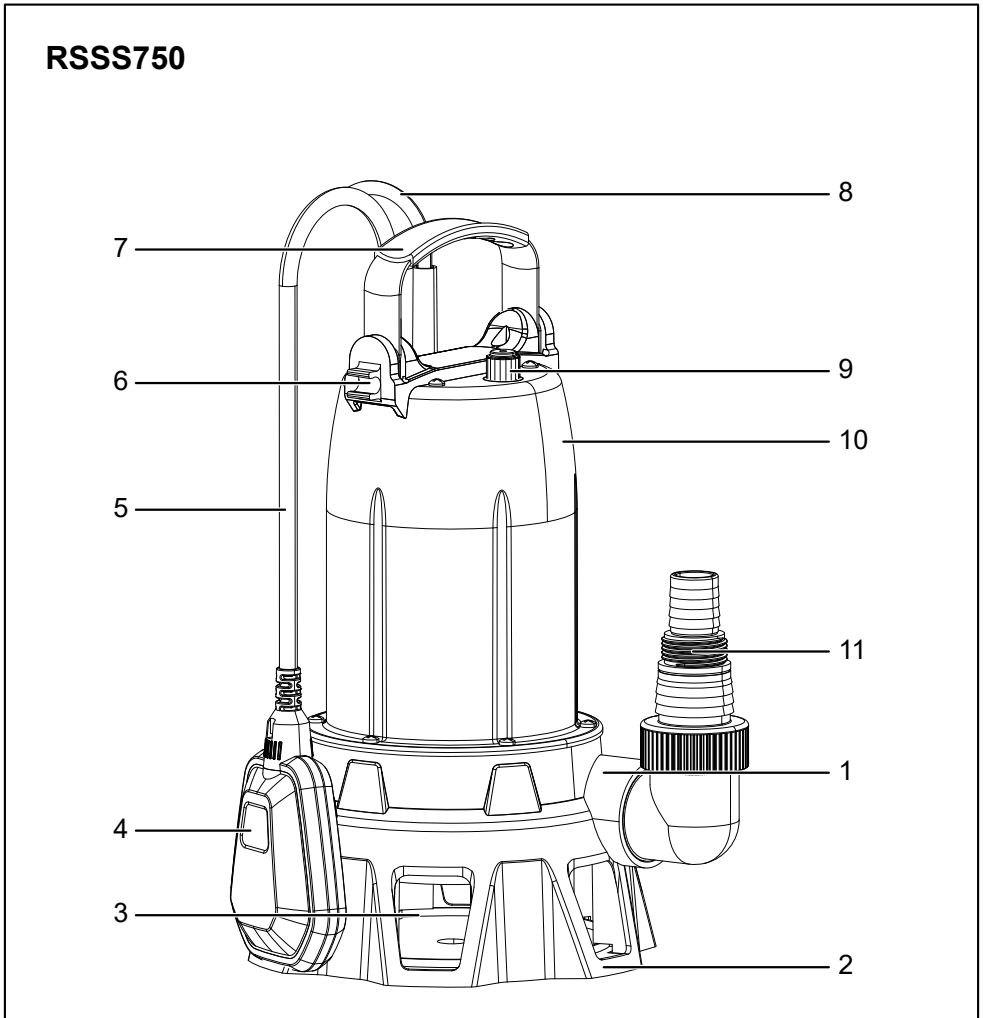

RSSS750 Components List

1. Water outlet
2. Pump base
3. Suction port
4. Floating switch
5. Cable of floating switch
6. Cable holder
7. Carry handle
8. Power cable
9. Pressure relief valve
10. Pump housing
11. Right angle adaptor
12. Thread seal tape

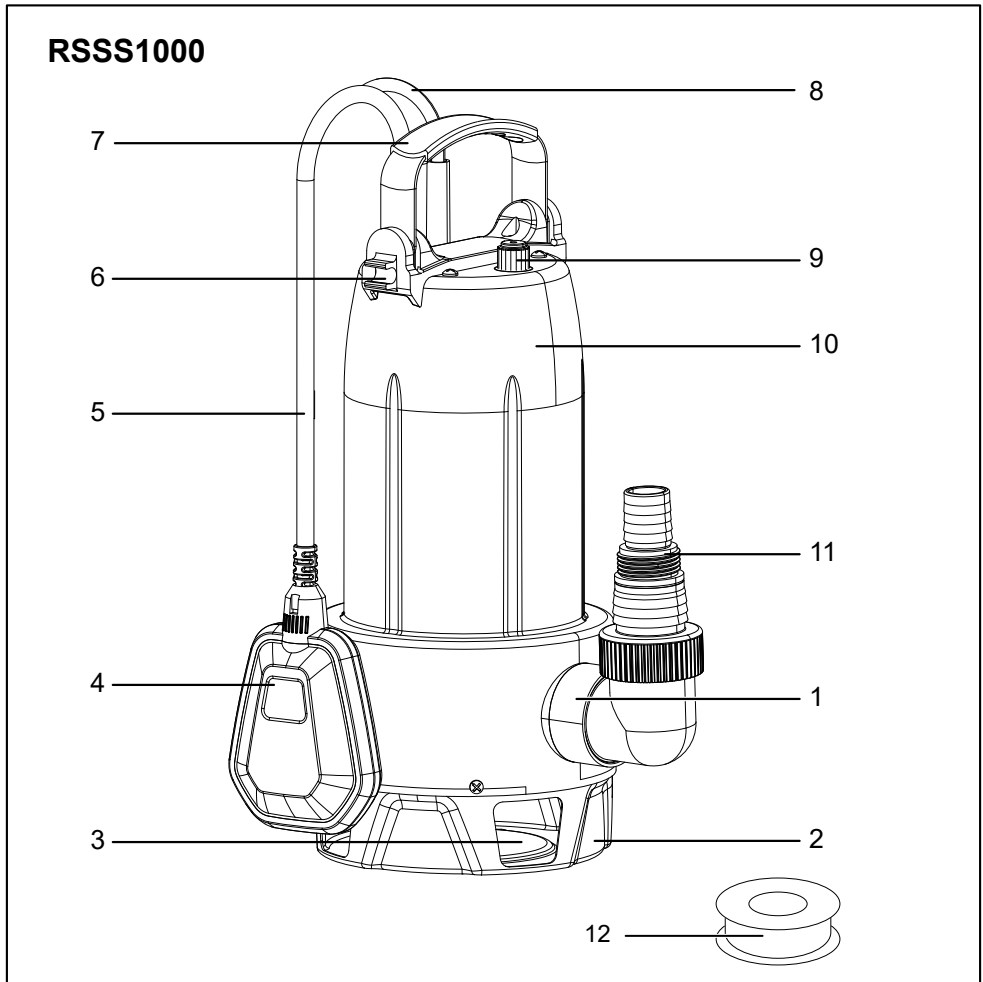

DESCRIPTION

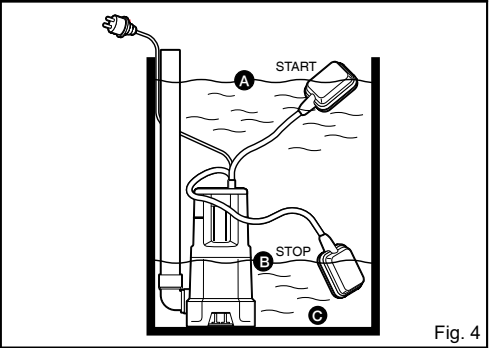
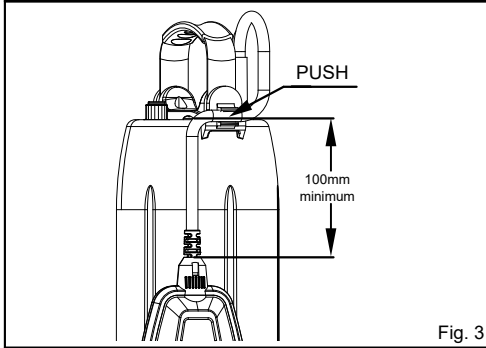
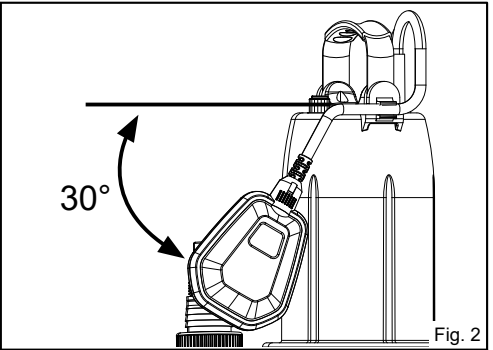
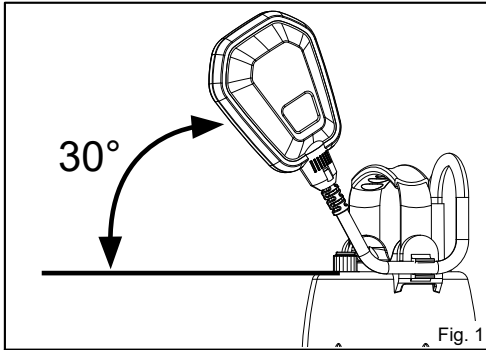

Important!

It is essential that you read the instructions in this manual before assembling, operating and maintaining the product.

Subject to technical modification.

GENERAL SAFETY WARNINGS

- **Read all safety warnings and all instructions.** Failure to follow the warnings and instructions may result in electric shock, fire and/or serious injury. Save all warnings and instructions for future reference.
- **Know your product. Read operator's manual carefully.** Learn its applications and limitations, as well as the specific potential hazards related to the product. Following the rule will reduce the risk of electric shock, fire, or serious injury.
- **Do not let familiarity gained from frequent use of tools allow you to become complacent and ignore tool safety principals.** A careless action can cause severe injury within a fraction of a second.
- **Follow appliance manufacturer's instructions regarding operation and power.** Use of the appliance different from those intended could result in a hazardous situation.
- **Use the correct product for the application.**
- **Do not allow children to operate the product or play with the product as a toy.** Close attention is necessary when used near children.
- **To reduce the risk of personal injury and electric shock, the product should not be played with or placed where small children can reach it.**
- **The product is intended for household use only.**
- **Use the product only for its intended use as described in this manual.**
- **Only use attachments and accessories specified by the manufacturer.**
- **Do not put any objects in ventilation openings.** Do not use the product with any opening blocked. Keep openings free of dust, lint, hair and anything that may reduce air flow.
- **Stay alert, watch what you are doing and use common sense when operating the product.** Do not use while you are tired or under the influence of drugs, alcohol or medication. A moment of inattention may result in serious personal injury.
- **Do not place product near any heat sources such as radiators, heat registers, stoves, or other products (including amplifiers) that produce heat.**
- **Do not place the product near fire or heat; it may explode.**
- **Risk of uncontrolled situations when used in ambient temperatures below 0°C (32°F) or above 40 °C (104°F).**
- **Keep the product dry, clean and free from oil and grease.** Always use a clean cloth when cleaning.
- **Keep handles and grasping surfaces dry, clean and free from oil and grease.** Slippery handles and grasping surfaces do not allow for safe handling and control of the tool in unexpected situations.
- **Do not overreach. Keep proper footing and balance at all times.** This enables better control of the product in unexpected situations.

- **When servicing the product, use only manufacturer's replacement parts, accessories and attachments.** Follow instructions in the Maintenance section of the manual. Use of unauthorised parts or failure to follow maintenance instructions may create a risk of shock or injury.
- **Save these instructions.** Refer to them frequently and use them to instruct others who may use this tool. If you loan someone this tool, loan them these instructions also **TRANSFER PUMP SAFETY WARNINGS**
- **Do not let the pump run dry.**
- **Do not remove hose while pump is still operating.**
- **Do not allow the product to run unattended.**
- **Do not lift the pump by the hoses.**
- **Periodically inspect the pump, hoses and water inlet.** Ensure hoses and water inlet are free from mud, sand and debris.
- If the replacement of the supply cord is necessary, this has to be done by the manufacturer or his agent in order to avoid a safety hazard; The pump is to be supplied through a residual current device (RCD) having a rated residual operating current not exceeding 30mA

RESIDUAL RISKS

▲ WARNING

This product is intended for pumping water in a Home Domestic application. Do not use it for corrosive, abrasive, explosive or dangerous liquids. Fluids other than water will damage the water pump and/or create a fire hazard. Failure to follow all instructions listed below may result in electric shock, fire and/or serious injury.

This appliance is not intended for use by person (including children) with reduced physical, sensory or mental capabilities, or lack of experience and knowledge, unless they have been given supervision or instruction concerning use of the appliance by a person responsible for their safety. Children should be supervised to ensure that they do not play with the appliance.

▲ WARNING

This product is not suitable for use with drinking (potable) water.

- Ensure the water pump is disconnected from mains power when installing.
- Do not install or operate the water pump in an explosive environment or near flammable material.
- Do not operate the water pump without liquid.
- Do not run the water pump dry.

- Avoid inserting hands into the inlets/outlets of the water pump while it is connected to power.
- Before using the water pump, always inspect it visually. Do not use the pump if it is cracked and/or damaged.
- The water pump has a built-in thermal protection overload switch. The water pump stops if an overload occurs. The motor restarts automatically after it has cooled down.
- The pump must not be used when people are in the water.
- Never work or perform maintenance on the pump without first making sure it has been disconnected from the mains power.
- Pollution of the liquid could occur due to leakage of lubricants.

Important: Avoid inserting hands into the mouth of the pump if it is connected to the mains. The electrical connection must always be made in a dry area. Make sure that electrical connections are protected from inundations.

Protect the plug and the power cable from heat, oil or sharp edges.

MAINTENANCE

⚠ WARNING

Make sure the pump is disconnected from electric power supply before performing maintenance procedures.

CLEANING THE PUMP HOUSING

Use a moist cloth to wipe down the pump housing. Allow to dry thoroughly before storing in a dry location that is protected from bad weather conditions.

SYMBOLS DEFINITION ON THE PRODUCT



Safety alert



Volts



Hertz



Alternating current



Watts



Connect to the power supply.



Disconnect from the power supply.



Parts or accessories sold separately



Regulatory Compliance Mark (RCM). Product meets applicable regulatory requirements.



Please read the instructions carefully before starting the machine.



Waste electrical products should not be disposed of with household waste. Please recycle where facilities exist. Check with your local authority or retailer for recycling advice.

⚠ WARNING

The water pump together with associated pipework operate under pressure. Do not disconnect water pump or pipework until internal pressure has been released. Failure to do this could result in personal injury and damage to property.

INTENDED USE

- RYOBI Submersible dirty water pumps are highly efficient electrical pumps for discharging clear or dirty water containing solids up to the maximum size specified in the technical details.
- This pump is intended for discharging clear or dirty water containing solids up to the maximum size 35mm
- Typical applications for waste water submersible pumps are: Emptying ponds, tanks, storage tanks, and waste water pits, emergency drainage in the event of flood etc. This product is intended for household use only, not for extended continuous operation.

⚠ WARNING

The pump is not suited to discharge salt water, sewage, flammable, caustic or hazardous liquids. Please observe the max. temperature of the liquids to be discharged stated in the technical data.

- A distinctive feature of this pump is that it can briefly operated (max. 4 min.) with liquids with a temperature up to 95°C (see Technical data).

⚠ WARNING

Inside the pump, lubricants are used which may contaminate the liquids being discharged in case of any improper operation or damage of the device. The lubricants used are biologically degradable and nonhazardous to health.

INSTALLATION

⚠ WARNING

During the entire process of installation, the device must not be connected to the electrical mains. The pump and the entire connection system have to be protected from frost.

- Ensure all connections are leak free. Use the included thread seal tape (12) (included with RSSS1000 only) or a suitable sealant on the connection thread.
- When tightening threaded connections, please do not apply excessive force which may cause damage.
- When laying the connection pipes, you should make sure that the pump is not exposed to any form of weight, vibration or tension. Moreover, the connection lines must not contain any kinks.

INSTALLATION OF THE PRESSURE LINE

The pressure line conveys the liquids to be discharged from the pump to the point of withdrawal. To avoid dynamic flow losses, one should use a pressure line having at least the same diameter as the water outlet (1) of the pump.

1. Screw the connection adaptor (10) into the pump outlet.
2. Screw the connection port into the connection adaptor.
3. Fix a hose to the combination nipple, use a hose clamp to secure the hose.

STATIONARY INSTALLATION

If the unit is used in a stationary installation, rigid pipes have proven to be the ideal choice for the pressure lines. In this type of installation, we recommend that you incorporate a check valve (non-return valve) in the pressure line immediately following the pump outlet so that no liquid will flow back after the pump cuts out. To facilitate maintenance work, we also recommend the installation of a stop cock valve downstream of the pump and check valve. This arrangement is beneficial in that closing the stop cock will prevent the pressure line from running dry after the disassembly of the pump.

HOW TO SET FLOAT SWITCH

⚠ WARNING

Please make sure that the pump will cut out as soon as the water level decreases and the floating switch has reached the cut-out level.
Also it must be made sure that the floating switch can move freely.

The pump is fitted with a float switch, which controls how the pump switches on and switches off.

1. When the float switch is about 30° higher than horizontal (start up level) or above the handle, the pump will turn 'on' and operate. (Fig. 1)
2. When the float switch is 30° lower than the horizontal or below the handle, the pump will turn 'off'. (Fig. 2)
3. To set the pump to switch off at a lower water level, insert the float switch cable into the adjuster Note: There must be a minimum of 100mm of cable from the adjuster to the float. (Fig. 3)
4. Manual mode: when the float is manually secured at ON position, the pump can draw down to a minimum level of 54mm (at 0m delivery height) (Fig. 4)

⚠ WARNING

The pump **MUST** be attended when used in this mode as the motor receives no cooling and can over heat.

HOW TO POSITION THE PUMP

- When positioning the pump, please make sure that the max. immersion depth indicated in the technical data will not be exceeded.
- Likewise, please make sure that the minimum

selfpriming level is not fallen short of. If everything is properly set, the water level may decrease down to the minimum suction level once the pump is operating. Please position the pump on solid ground. Avoid placing it on loose stones or sand.

- When positioning the pump, elevate it from the bottom such that sediment and debris will not be sucked into the inlet. This will protect the impellers as well as maintain flow performance
- To position, lift up or carry the pump, please use only the carrying handle(7).
- If required for lowering or raising the pump, you must connect a suitable lowering rope to the carrying handle. **DO NOT** lift pump using the hose, power cord or float cable.

ELECTRICAL CONNECTION

- The unit is equipped with a power connection cable and a plug. It must only be replaced by qualified staff to avoid any danger. Please do not use the power cable to carry the pump, and do not use this cable to pull off the plug from the socket, either. Protect the power cable and mains plug from heat, oil or sharp edges.
- The values stated in the technical details have to correspond to the mains voltage. The person responsible for the installation has to make sure that the electrical connection is earthed in compliance with the applicable standards.
- The electrical connection has to be equipped with a highly sensitive residual current circuitbreaker (Flswitch) : $\Delta = 30$ mA.
- If extension cables are used, their cross-section must not be smaller than that of rubbersheathed cables of the H07RN-F (3 x 1,0 mm²) short code. The mains socket and the plug-and-socket elements have to be in splash water-proof design.

PUTTING INTO OPERATION

- Nobody must be in the water while the pump is running.
- The pump must only be operated in the performance range indicated on the type plate.
- Dry-running - i.e. operating the pump without discharging water is to be avoided since the absence of water may cause the pump to run hot. This may cause considerable damage on the device.
- Please make sure that the electrical plug connections are in flood-proof area.
- As long as the device is connected to the electrical mains, one must never reach with one's hands into the opening of the pump.
- Please inspect the pump visually prior to each use.
- This applies in particular to the mains connection line and the mains plug. Make sure that all screws are firmly tightened, and verify the perfect condition of all connection. A damaged pump must not be used. In any case of damage, the pump has to be

inspected by qualified service staff. Each time the pump is put into operation, please make sure that the pump is set up securely and firmly standing.

- To put the unit into operation, please plug the mains plugs into a socket. If the water level has reached or exceeded the cut-in level, the pump will start to run immediately. To stop the operation of the pump, please pull the mains plug off the socket.
- The electrical RYOBI pumps are equipped with an integrated thermal motor protection feature. In the case of overload, the motor will switch off independently and on again after cooling down. For possible causes and their elimination, please refer to the "Maintenance and troubleshooting" section. Please note that the pump can only be operated with liquids > 50°C for a short period of time (see Technical data).
- Your pump is equipped with a purge which is used to evacuate the air. Ensure that this purge is clean.

MAINTENANCE AND TROUBLE SHOOTING

WARNING

Prior to carrying out any maintenance work, the pump must be separated from the electrical mains. If you fail to separate the unit from mains, there is a risk of an inadvertent start of the pump.

WARNING

We decline any liability for damage caused by inappropriate repair attempts. Any damage caused by inappropriate repair attempts will void all warranty claims.

- Observing the conditions of use and the ranges of application of the present device will reduce the risk of possible operational malfunction and contribute to extend the lifetime of your unit. Sand and other abrasive matters contained in the liquid discharged will speed up the process of wearing and tearing and accelerate the drop in performance.
- If the unit is operated properly, it will not require any maintenance. Where applicable, you may clean the hydraulic part from sediments and dirt. This can be done by counter-flushing the unit with clear water using a hose to be connected through the pressure port of the pump. To remove tenacious dirt, the foot of the pump (2) can be removed by loosening the screws located at the bottom of the pump. To avoid any hazard, any further disassembly as well as the replacement of parts must only be done by the manufacturer or a by an authorised service provider.
- Water left in the pump may freeze in case of frost and thus cause considerable damage. Therefore, the pump must be removed from the liquid being discharged and fully drained when temperatures are below the freezing point of the liquid. Please store the pump in a dry, frost-protected place.
- In the case of malfunction, you should first of all check whether it it was caused by an operating error or some other reason which cannot be attributed to

a defect of the device - for instance a power failure.

- The list below shows some possible malfunctions of the device, possible causes and tips on their elimination. All the measures referred to may only be carried out with the pump being separated from the electrical mains. If you yourself feel eliminate any of these malfunctions, please contact unable to the customer service department or your point of sales. Any repair beyond the scope specified below must only be performed by qualified staff. Please bear in mind that all warranty claims will become void in the case of damage caused by inappropriate repair attempts, and that we decline any liability for any ensuing damage.
- Nobody must be in the water while the pump is running. The pump must only be operated in the performance range indicated on the type plate.
- Dry-running - i.e. operating the pump without discharging water is to be avoided since the absence of water may cause the pump to run hot. This may cause considerable damage on the device.
- Please make sure that the electrical plug connections are in flood-proof area.
- As long as the device is connected to the electrical mains, one must never reach with one's hands into the opening of the pump.
- Please inspect the pump visually prior to each use.
- This applies in particular to the mains connection line and the mains plug. Make sure that all screws are firmly tightened, and verify the perfect condition of all connection. A damaged pump must not be used. In any case of damage, the pump has to be inspected by qualified service staff. Each time the pump is put into operation, please make sure that the pump is set up securely and firmly standing.
- To put the unit into operation, please plug the mains plugs into a socket. If the water level has reached or exceeded the cut-in level, the pump will start to run immediately. To stop the operation of the pump, please pull the mains plug off the socket.
- Your pump is equipped with a purge which is used to evacuate the air. Ensure that this purge is clean.

SPECIFICATIONS

RSSS750

Rated Power	750W
Max Head	9m
Max. Immersion Depth	7m
Max. Water Flow	17,000L/hr
Max. Working Temp.	35°C
Max. Particle Size	35mm
Cable Length	10m

RSSS1000

Rated Power	1000W
Max Head	10.5m
Max. Immersion Depth	7m
Max. Water Flow	19,500L/hr
Max. Working Temp.	35°C
Max. Particle Size	35mm
Cable Length	10m

COMMON FAILURES AND TREATMENT

Malfunction	Possible cause	Elimination
The pump is not discharging any liquid, the motor is not running.	Thermal motor protection feature has triggered. (for information on operation with liquids > 50°C, see the note in Technical data).	Separate the pump from the electrical mains, allow the system to cool down, eliminate cause.
	The min. suction level was fallen short of; possibly incorrect setting of the floating switch, motion of floating switch restricted, floating switch defective.	Make sure that the minimum suction level is not fallen short of; if necessary, adjust floating switch properly or make sure that it can move freely; in the case of a defective floating switch, check the output hose is not blocked or crimped please contact customer service.
	The capacitor is defective.	Please contact the customer service department.
	The pump wheel is blocked.	Eliminate blocking of pump wheel.
	The floating switch is defective.	Please contact the customer service department.
The motor is running, but the pump is not discharging any liquid.	The intake openings are clogged.	Remove possible congestion.
	The pressure line is clogged or kinked.	Remove possible congestion / kink in the line.
	Air penetrates into the pump body.	Start pump several times so that the entire air will be driven out.
	Check valve (non-return valve), if present, is blocked or defective.	Eliminate blocking of the check valve (nonreturn valve) or replace, if damaged.
The pump stops after a short time of operation because the thermal motor protection feature has triggered.	Pump or intake openings are blocked by solids.	Remove possible congestion.
	Liquid is too viscous.	Pump may not be suitable for this liquid. If feasible, the liquid should be thinned.
	Temperature of the liquid is too high.	Make sure that the temperature of the liquid being pumped does not exceed the max. admissible value.
	Pump is running dry.	Eliminate causes of dry-running.
Intermittent or irregular operation.	Pump wheel obstructed by solid matters.	Remove solids.
	Mains voltage out of tolerance.	Make sure that mains voltage matches that indicated on the type plate.
	Motor or pump wheel defective.	Please contact the customer service department.
The pump does not cut in or out.	Floating switch cannot move freely.	See that floating switch can move freely.
	Incorrect setting of floating switch.	Correct floating switch settings.
	Floating switch defective.	Please contact the customer service department.



Imported by:

Techtronic Industries Australia Pty Ltd
31 Gilby Road, Mount Waverley, VIC 3149
Melbourne, Australia

Techtronic Industries N.Z. Limited
Unit C
70 Business Parade South
Highbrook
Auckland 2013
New Zealand