

RYOBI®

RBL3600

ORIGINAL INSTRUCTIONS

36V Cordless Blower



Important!

It is essential that you read the instructions in this manual before assembling, operating and maintaining the product.

Subject to technical modification.

Safety, performance, and dependability have been given top priority in the design of your cordless blower.

INTENDED USE

The cordless blower is intended only for outdoor use, in dry, and well-illuminated conditions.

The product is not intended to be used by children or persons with reduced physical, mental, or sensory capabilities.

The product is designed for blowing light debris, such as leaves, grass, and other garden refuse.

Do not use the product for any other purpose.

GENERAL SAFETY WARNINGS

⚠ WARNING

When using the product, the safety rules must be followed. For your own safety and that of bystanders, you must read and fully understand these instructions before operating the product. Keep these instructions safe for later use.

⚠ WARNING

This product is not intended to be used by children or persons with reduced physical, mental, or sensory capabilities. Children should be adequately supervised to ensure that they do not play with the product.

TRAINING

- Read the instructions carefully. Be familiar with the controls and the correct use of the product.
- Never allow children, persons with reduced physical, sensory or mental capabilities or lack of experience and knowledge, or people who are unfamiliar with these instructions to use the product. Local regulations may restrict the age of the operator.
- Keep in mind that the operator or user is responsible for accidents or hazards occurring to other people or their property.
- Keep bystanders, children and pets 15 m away from the area of operation. Stop the product if anyone enters the area.

- Never use the product while tired, ill or under the influence of alcohol, drugs or medication.

PREPARATION

- Some regions have regulations that restrict the use of the product to some operations. Check with your local authority for advice.
- While operating the product, always wear substantial footwear and long trousers. Do not operate the product when barefoot or wearing open sandals. Avoid wearing clothing that is loose-fitting or that has hanging cords or ties; they can be caught in moving parts.
- Do not wear loose clothing or jewellery that can be drawn into the air inlet.
- Secure long hair so that it is above shoulder level to prevent entanglement in moving parts.
- Wear hearing protection at all times while operating the product. The product is noisy, and may cause permanent hearing injury if precautions to limit your exposure and to reduce noise are not strictly adhered to.
- Wear full eye protection at all times while operating this product. Wear a full face mask or fully enclosed goggles. Normal spectacles or sun glasses are not adequate protection. Objects can be thrown at high speed by the powerful air jet at any time and may rebound from hard surfaces toward the operator.
- Ensure before each use that all controls and safety devices function correctly. Do not use the product if the OFF switch does not stop the product.
- Before each use, always inspect the housing for damage. Ensure that guards and handles are in place and properly secured.
- Return the product to an authorised service centre to replace damaged or unreadable labels.
- Never operate the product with defective guards or shields, or without safety devices in place.
- Keep all cooling air inlets clear of debris.
- Use rakes and brooms to loosen debris before blowing.

- Clear the work area before each use. Remove all objects, such as rocks, broken glass, nails, wires, or string which can be blown a considerable distance by high velocity air.
- Operate the product on a firm, level surface only.

BATTERY TOOL USE AND CARE

- Recharge only with the charger specified by the manufacturer. A charger that is suitable for one type of battery pack may create a risk of fire when used with another battery pack.
- Use power tools only with specifically designated battery packs. Use of any other battery packs may create a risk of injury and fire
- When battery pack is not in use, keep it away from other metal objects, like paper clips, coins, keys, nails, screws or other small metal objects that can make a connection from one terminal to another. Shorting the battery terminals together may cause burns or a fire.
- Under abusive conditions, liquid may be ejected from the battery; avoid contact. If contact accidentally occurs, flush with water. If liquid contacts eyes, additionally seek medical help. Liquid ejected from the battery may cause irritation or burns.

OPERATION

- Operate the product only at reasonable hours – not early in the morning or late at night when people might be disturbed.
- Never operate the product in an explosive atmosphere.
- Avoid using the product in bad weather conditions especially when there is a risk of lightning.
- Do not operate the product in poor lighting. The operator requires a clear view of the work area to identify potential hazards.
- The use of hearing protection reduces the ability to hear warnings (shouts or alarms). The operator must pay extra attention to what is going on in the working area.
- Do not get distracted and always concentrate on the task.
- Operating similar tools nearby increases both the risk of hearing injury and the potential for other persons to enter the

working area.

- Keep firm footing and balance. Do not overreach. Overreaching can result in loss of balance.
- Always be sure of the footing on slopes. Walk, never run.
- Keep all parts of the body away from any moving part. Rotating impeller blades can cause severe injury.
- Never run the product without the proper equipment attached.
- Do not modify the product in any way or use parts and accessories which are not recommended by the manufacturer.

⚠ WARNING

If the product is dropped, suffers heavy impact, or begins to vibrate abnormally, immediately stop the product and inspect for damage or identify the cause of the vibration. Any damage should be properly repaired or replaced by an authorised service centre.

⚠ WARNING

The product may be supplied with a harness. Carefully adjust the harness to comfortably help you in supporting the weight of the product.

Identify the quick-release mechanism and practice using it before you start using the product. Its correct use may prevent serious injury in the case of an emergency. Never wear additional clothing over the harness or otherwise restrict access to the quick-release mechanism.

- To reduce the risk of injury associated with contacting rotating parts, always stop the product, remove the battery pack, and make sure all moving parts have come to a stop:
 - before cleaning or clearing a blockage
 - when leaving the product unattended
 - before installing or removing attachments
 - before checking, maintaining, or working on the product
 - to inspect the product for damage after striking a foreign object

- if the product starts to vibrate abnormally (inspect immediately)
- Immediately turn off the product and remove the battery pack in the event of accident or breakdown. Do not operate the product again until it has been fully checked by an authorised service centre.

BLOWER SAFETY WARNINGS

- Wear a face filter mask in dusty conditions to reduce the risk of injury associated with the inhalation of dust.
- Slightly dampen surfaces in dusty conditions.
- Do not point the blower nozzle in the direction of people or pets.
- Never place objects inside the blower tubes.
- Do not operate the product near open windows.
- Use the full blower nozzle extension so that the air stream can work close to the ground and perform effectively.
- Do not place the product on top of or near loose debris. Debris can be sucked into the intake vent, resulting in possible damage to the product.

ADDITIONAL BATTERY SAFETY WARNINGS

⚠ WARNING

To reduce the risk of fire, personal injury, and product damage due to a short circuit, never immerse the product, battery pack or charger in fluid or allow fluid to flow inside them. Corrosive or conductive fluids, such as seawater, certain industrial chemicals, and bleach or bleach-containing products, etc., can cause a short circuit.

TRANSPORTATION AND STORAGE

- Stop the product, remove the battery pack, and allow it to cool down before storing or transporting.
- Clean all foreign materials from the product. Store the product in a cool, dry, and well-ventilated place that is inaccessible to children. Keep the product away from corrosive agents, such as garden chemicals and de-icing salts. Do not store the product outdoors.

- For transportation in vehicles, secure the product against movement or falling to prevent injury to persons or damage to the product.

TRANSPORTING LITHIUM BATTERIES

Transport the battery in accordance with local and national provisions and regulations.

Follow all special requirements on packaging and labelling when transporting batteries by a third party. Ensure that no batteries can come in contact with other batteries or conductive materials while in transport by protecting exposed connectors with insulating, non-conductive caps or tape. Do not transport batteries that are cracked or leaking. Check with the forwarding company for further advice.

MAINTENANCE

⚠ WARNING

Use only original manufacturer's replacement parts, accessories, and attachments. Failure to do so can cause possible injury, can contribute to poor performance, and may void the warranty.

⚠ WARNING

Servicing requires extreme care and knowledge and should be performed only by a qualified service technician. Have the product serviced by an authorised service centre. When servicing, use only original replacement parts.

- Do not make adjustments and repairs not described in this manual. For other repairs, contact an authorised service agent.
- After each use, clean the product with a soft, dry cloth.
- Check all nuts, bolts, and screws at frequent intervals for proper tightness to ensure that the product is in safe working condition. Any part that is damaged should be properly repaired or replaced by an authorised service centre.
- Bring the product to an authorised service centre to replace damaged or unreadable labels.

CLEARING A BLOCKAGE

- To reduce the risk of injury associated with contacting moving parts, always turn off the product, remove the battery pack, and make sure that all moving parts have come to a complete stop.
- Remove the blower tubes to inspect for blockage. Clear the tubes if required.
- Reinstall the blower tubes before starting the product.

WHAT'S IN THE BOX

- 1 x Blower assembly
- 1 x Blow tube
- 1 x High speed nozzle
- 1 x Manual

SYMBOLS ON THE PRODUCT



Read and understand all instructions before operating the product. Follow all warnings and safety instructions.



Do not expose to rain or damp conditions.



Wear ear protection.



Wear eye protection.



Beware of thrown or flying objects. Keep all bystanders at least 15 m away.



Rotating Fans. Keep hands and feet out of the openings while the product is running.



Remove the battery before starting any work on the product.



Guaranteed sound power level



Regulatory Compliance Mark (RCM). This product meets applicable regulatory requirements.



Waste electrical products should not be disposed of with household waste. Please recycle where facilities exist. Check with your Local Authority or retailer for recycling advice.

SYMBOLS IN THIS MANUAL



Note



Warning



Parts or accessories sold separately

The following signal words and meanings are intended to explain the levels of risk associated with this product.

DANGER

Indicates an imminently hazardous situation, which, if not avoided, will result in death or serious injury.

WARNING

Indicates a potentially hazardous situation, which, if not avoided, could result in death or serious injury.

CAUTION

Indicates a potentially hazardous situation, which, if not avoided, may result in minor or moderate injury.

CAUTION

Without safety alert symbol

Indicates a situation that may result in property damage.



WHAT'S IN THE BOX

RBL3600

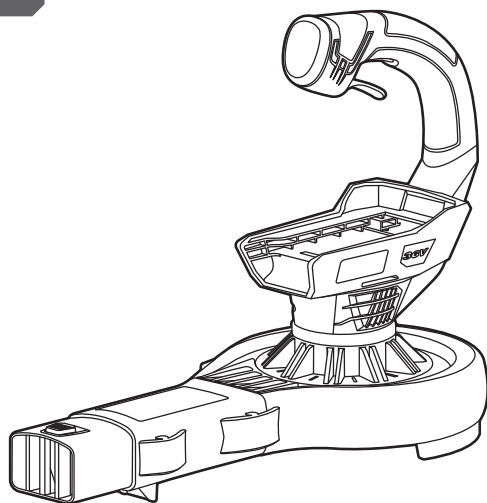

x 1

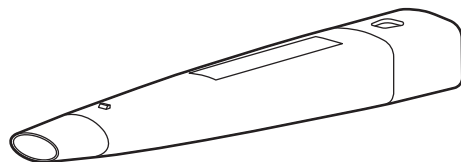

x 1



x 1



x 1

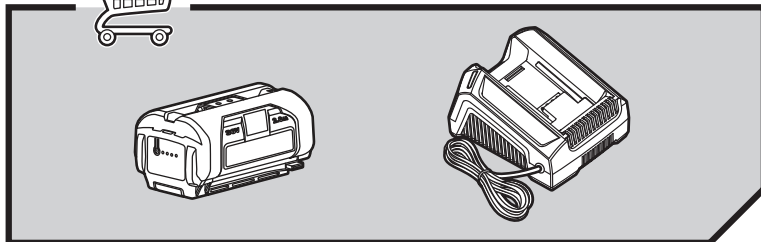

KNOW YOUR PRODUCT

1. Handle
2. Variable speed trigger
3. Blow tube
4. Charger (sold separately)
5. Battery pack (sold separately)
6. Battery latch button
7. High speed nozzle
8. Blow tube outlet
9. Nozzle tab
10. Blower housing outlet
11. Tube latch

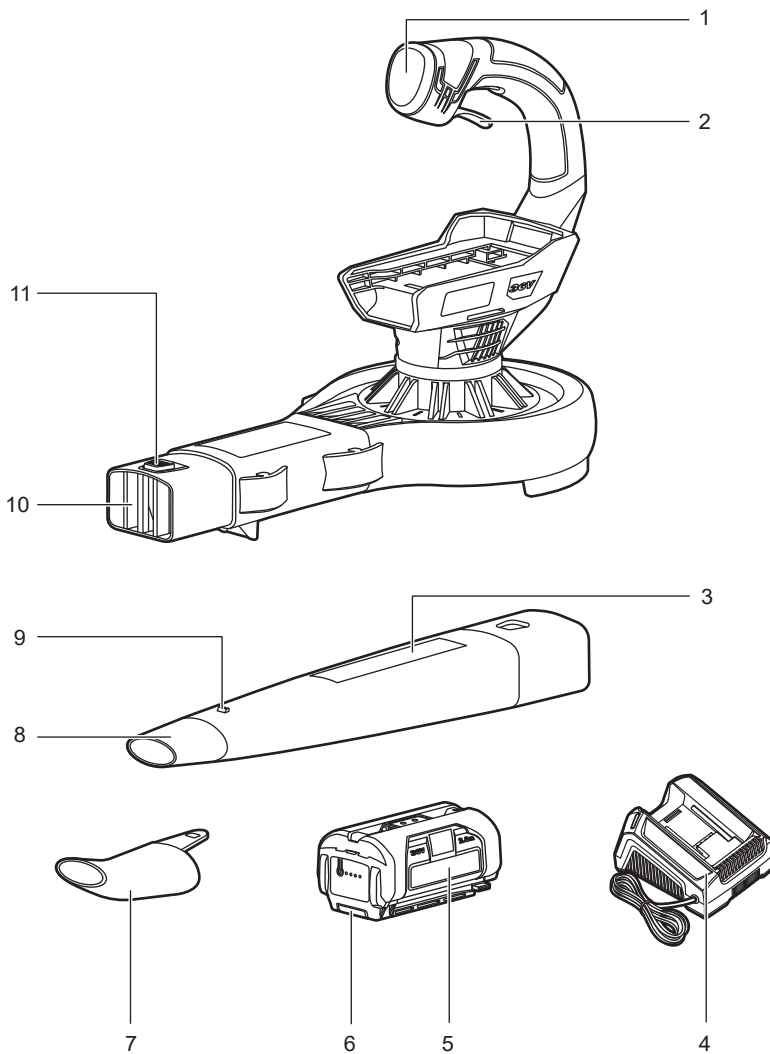

GETTING STARTED

1

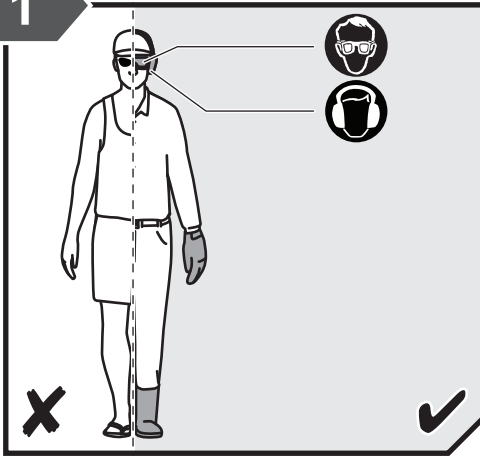

Wear full eye and ear protection, substantial footwear, and long trousers at all times while operating the product. Do not operate the product when barefoot or wearing open sandals.

2

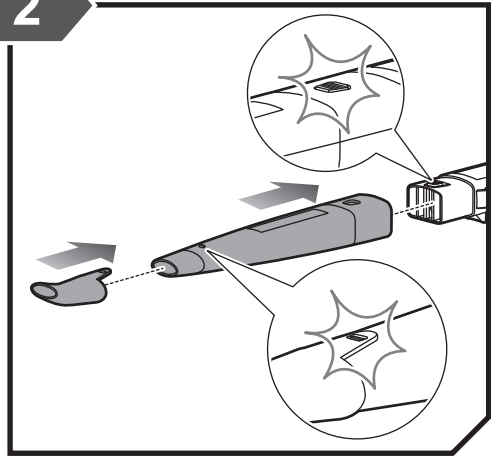

Insert the high-speed nozzle into the blow tube outlet until it clicks into place. Insert the blow tube into the product until it clicks into place.

3

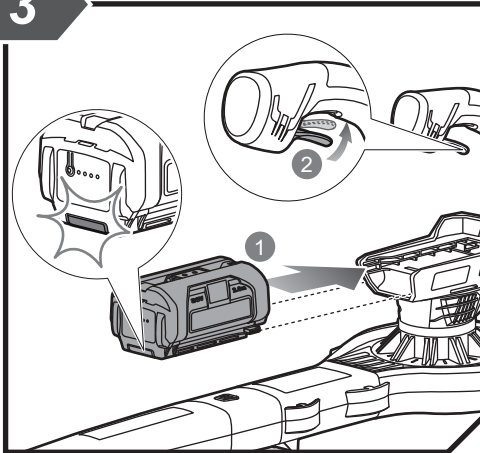

Insert the battery pack until it clicks into place. Press the variable speed trigger to operate the product.

i

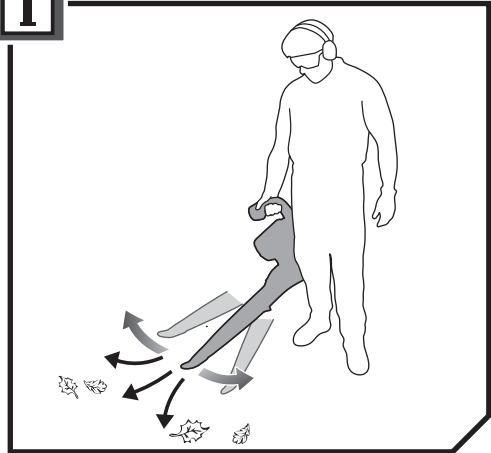

Hold the handle with your right hand and point to the intended area of operation.

OVERVIEW

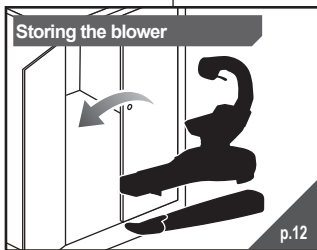
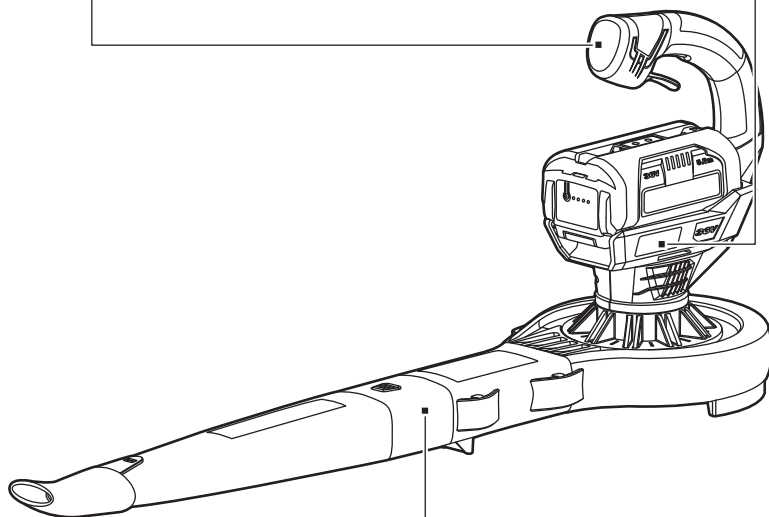
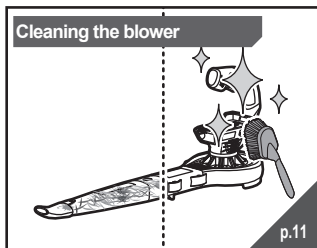
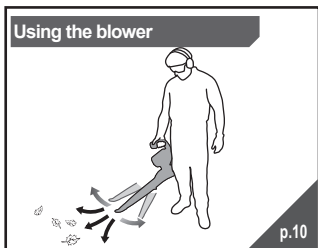

OPERATION

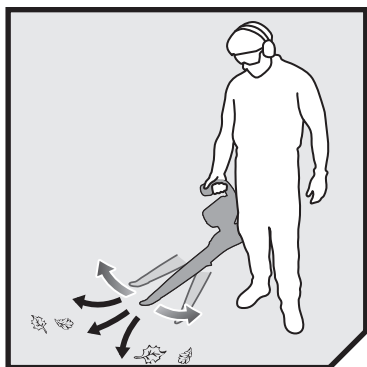

USING THE BLOWER

1. Insert the battery pack until it clicks into place.
2. Press the trigger to turn on the product. Let the air stream work close to the ground.

WARNING! Do not use the product without the blower tube securely attached.

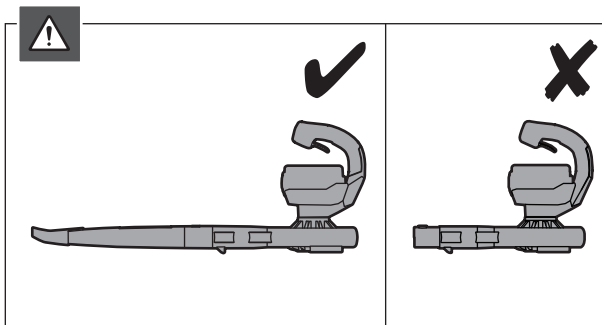
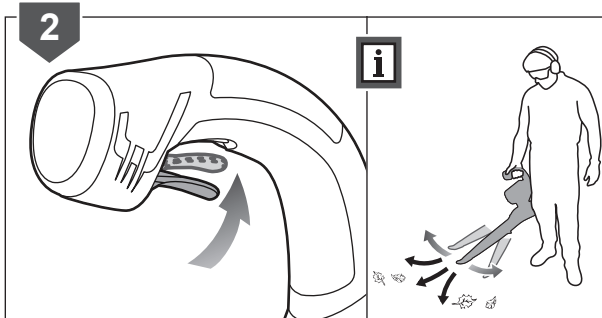
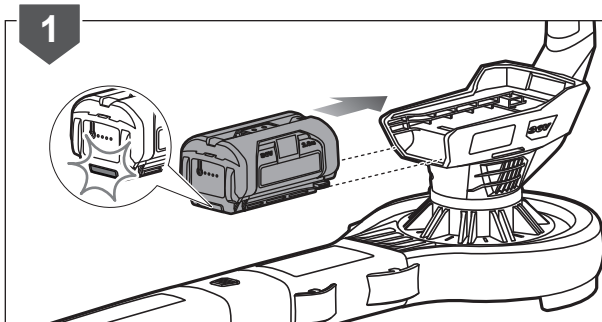

MAINTENANCE

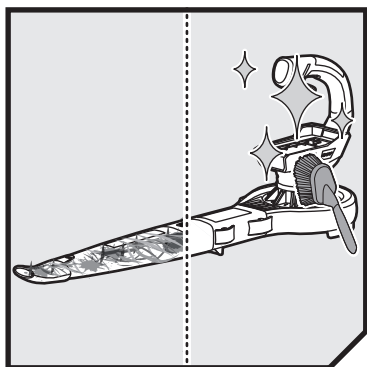

CLEANING THE BLOWER

1. Press the battery latch button, and remove the battery pack.
2. Clean the blower using a brush.

WARNING! Avoid using solvents when cleaning plastic parts. Most plastics are susceptible to damage from various types of commercial solvents and may be damaged by their use. Use a clean brush to remove dirt, dust, lubricant, grease, etc.

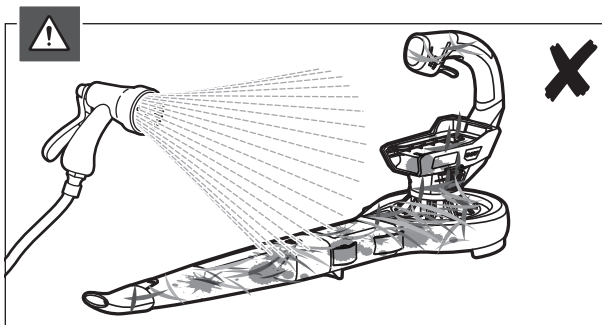
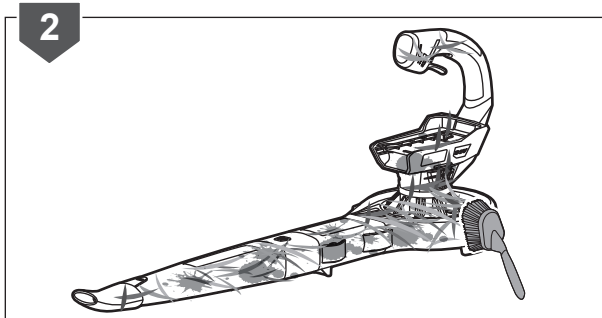
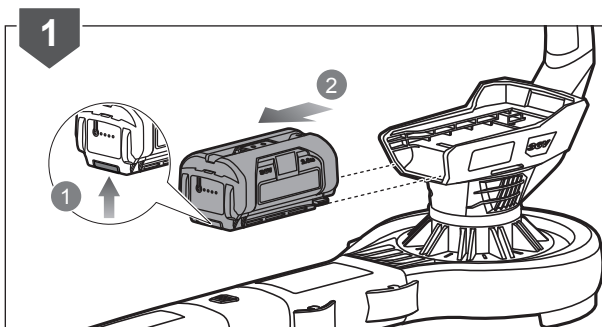

STORAGE



STORING THE BLOWER

1. Press the battery latch button, and remove the battery pack.
2. Press the blow tube latch and remove the blow tube.
3. Store the product in a cool, dry, and well-ventilated place that is inaccessible to children.

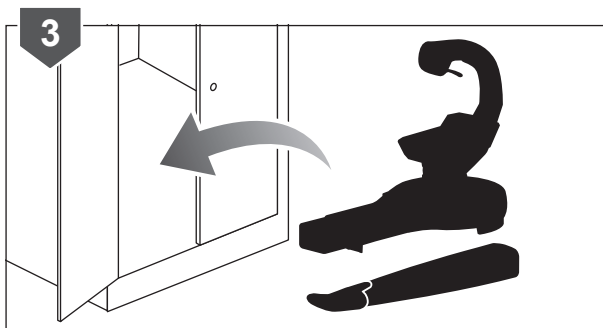
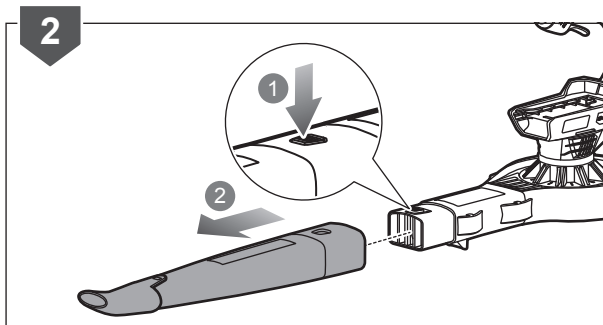
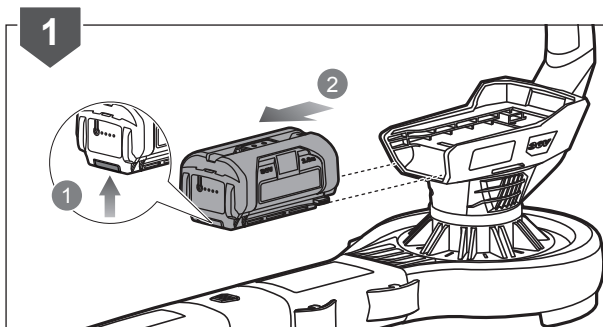

PRODUCT SPECIFICATIONS

36V Cordless blower	
Model	RBL3600
Rated voltage	36 V
Maximum air velocity	264 km/h
Weight (without battery)	1.90 kg
Weight (with heaviest battery)	4.7 kg
Vibration level (in accordance with Annex BB of EN 50636-2-100:2014)	
Vibration total value	$a_h = 0.3 \text{ m/s}^2$
Uncertainty of measurement	$K = 1.5 \text{ m/s}^2$
Noise emission level (in accordance with Annex CC of EN 50636-2-100:2014)	
A-weighted sound pressure level at operator's position	$L_{PA} = 80.8 \text{ dB(A)}$
Uncertainty of measurement	$K = 2.5 \text{ dB}$
A-weighted sound power level	$L_{WA} = 94.0 \text{ dB(A)}$
Uncertainty of measurement	$K = 2.5 \text{ dB}$

BATTERY AND CHARGER

Model	RBL3600
Battery pack	not included
Weight	-
Charger	not included
Weight	-
Compatible battery pack	BPL3620D, BPL3640D2, BPL3650D2, BPL3660D, BPL3690D, BPL3612D
Compatible charger	BCL3660F, BCL3617U, BCL3617S

VIBRATION LEVEL

The declared vibration total values and the declared noise emission values given in this instruction manual have been measured in accordance with a standardised test and may be used to compare one tool with another. They may be used for a preliminary assessment of exposure.

The declared vibration and noise emission values represent the main applications of the tool. However, if the tool is used for different applications, used with different accessories, or poorly maintained, the vibration and noise emission may differ. These conditions may significantly increase the exposure levels over the total working period.

An estimation of the level of exposure to vibration and noise should take into account the times when the tool is turned off or when it is running idle. These conditions may significantly reduce the exposure level over the total working period.

Identify additional safety measures to protect the operator from the effects of vibration and noise, such as maintaining the tool and the accessories, keeping the hands warm (in case of vibration), and organising work patterns.



*RYOBI is a trade mark of Ryobi Limited,
and is used under license.*
© 2017-20 Techtronic Cordless GP.

Imported by:

Techtronic Industries Australia Pty Ltd
31 Gilby Road, Mount Waverley, VIC 3149,
Melbourne, Australia

Techtronic Industries N.Z. Limited
Unit C, 70 Business Parade South,
Highbrook, Auckland 2013, New Zealand

960746013-01