

4 TIER ADJUSTABLE SHELF

1830H x 1200W x 540Dmm

ITEM NO: GOS092

Very Important: Unpack the unit and confirm that you have all the parts listed. Assemble the unit on a solid, level surface. Avoid carpet. You will need the assistance of a second person during assembly. **Safety tip:** For added safety and support we recommend you fix unit to a wall. **You will need the following:** Rubber mallet or a hammer.



WARNING

SERIOUS INJURY OR DEATH CAN BE CAUSED BY TOPPLING FURNITURE

TO HELP PREVENT A TIP-OVER:

•Anchor this product to a wall or other suitable surface with the provided "Tip over prevention kit". •Check anchors regularly

FOR MORE INFORMATION SEARCH: www.productsafety.gov.au

POWDER COATED
MATTE BLACK

450kg
PER SHELF

SAFETY TIP:

When assembling or installing this product wear protective gloves and eyewear.

NOTE: This product has been tested to safely carry a load of up to 1800kg evenly distributed, when properly installed and maintained. Heaviest items to be loaded on lowest shelves.

Parts List

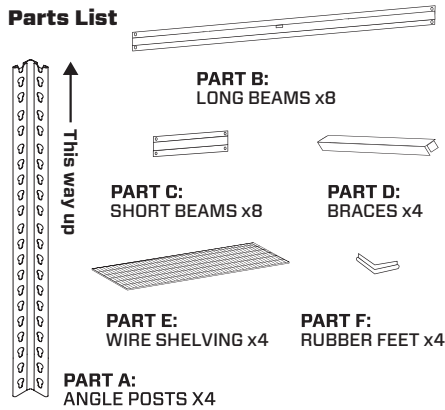

PART A:
ANGLE POSTS X4

PLEASE NOTE: Tip-over prevention kit included (refer to last step for installation).

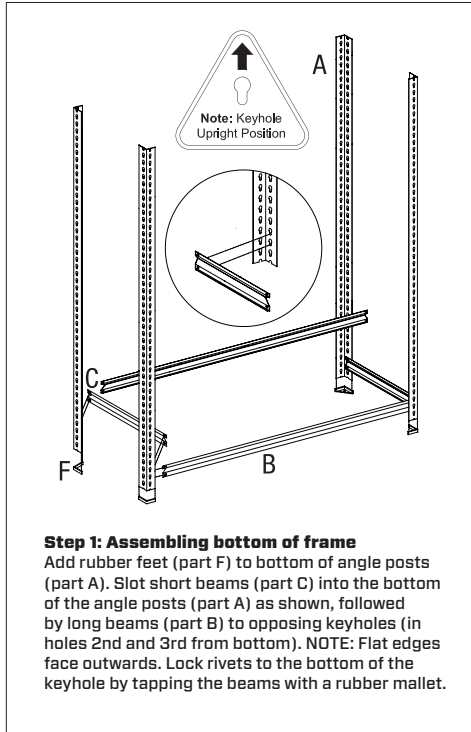

Step 1: Assembling bottom of frame

Add rubber feet (part F) to bottom of angle posts (part A). Slot short beams (part C) into the bottom of the angle posts (part A) as shown, followed by long beams (part B) to opposing keyholes (in holes 2nd and 3rd from bottom). **NOTE:** Flat edges face outwards. Lock rivets to the bottom of the keyhole by tapping the beams with a rubber mallet.

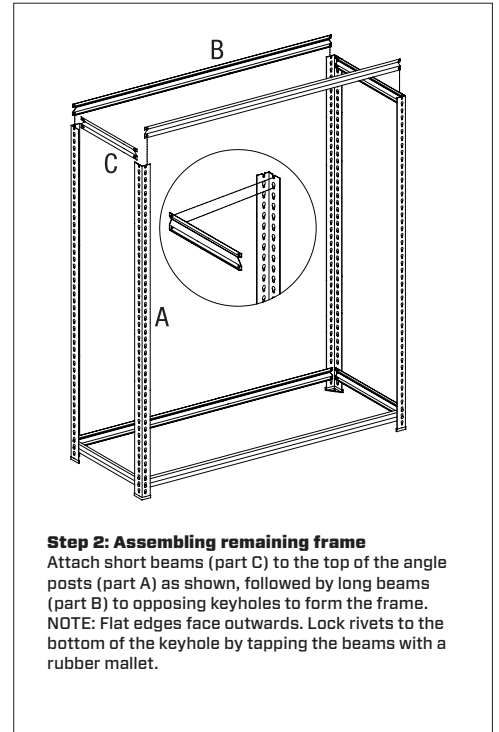

Step 2: Assembling remaining frame

Attach short beams (part C) to the top of the angle posts (part A) as shown, followed by long beams (part B) to opposing keyholes to form the frame. **NOTE:** Flat edges face outwards. Lock rivets to the bottom of the keyhole by tapping the beams with a rubber mallet.

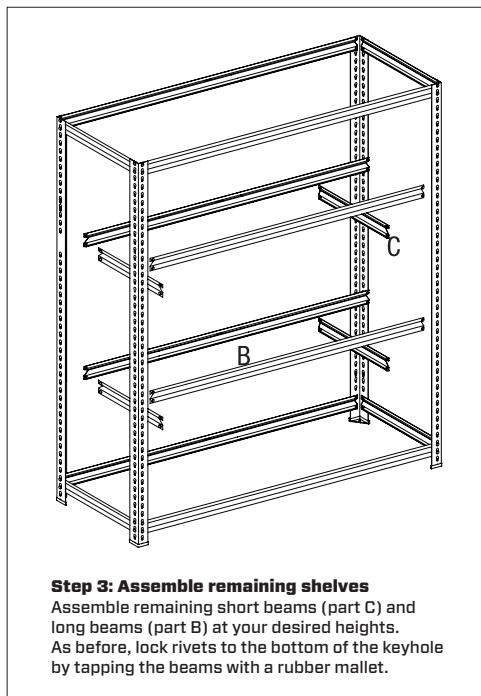

Step 3: Assemble remaining shelves

Assemble remaining short beams (part C) and long beams (part B) at your desired heights. As before, lock rivets to the bottom of the keyhole by tapping the beams with a rubber mallet.

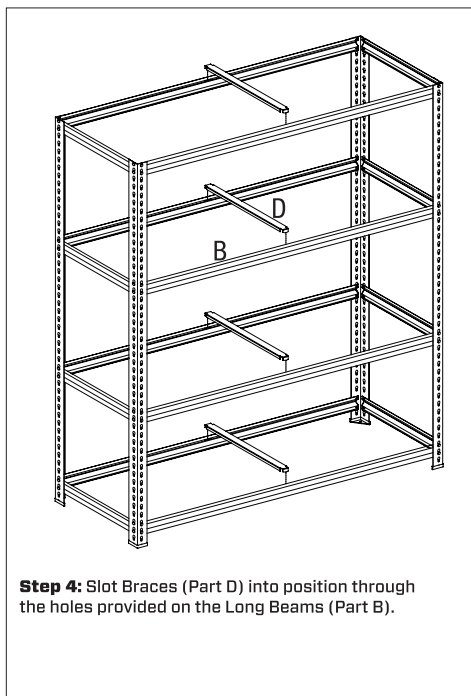

Step 4: Slot Braces (Part D) into position through the holes provided on the Long Beams (Part B).

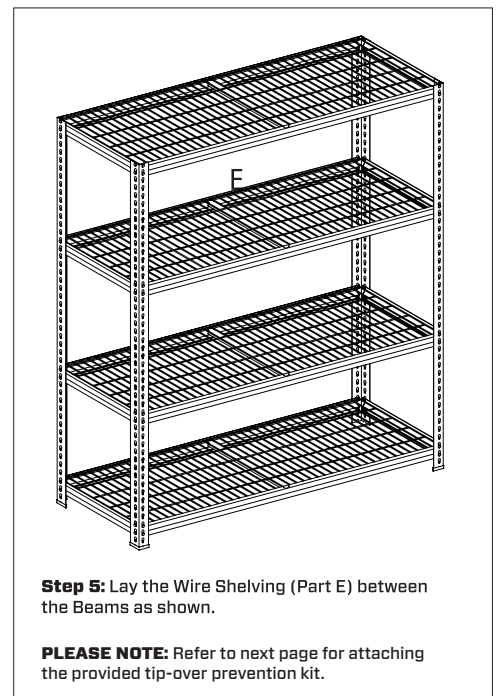

Step 5: Lay the Wire Shelving (Part E) between the Beams as shown.

PLEASE NOTE: Refer to next page for attaching the provided tip-over prevention kit.





WARRANTY CONDITIONS: Any claim under this warranty must be made within 1 year of the date of purchase of the product. To make a claim under this warranty, take the product (with proof of purchase) to any Bunnings store (for AUS customers see www.bunnings.com.au and for NZ customers see www.bunnings.co.nz for store locations). Pinnacle Hardware bears reasonable, direct expenses of claiming under the warranty. You may submit details and proof of purchase to our support centre for consideration. The warranty covers manufacturer defects in materials, workmanship and finish under normal use. This warranty is provided in addition to other rights and remedies you may have under law. Our goods come with guarantees that cannot be excluded under the Australian consumer law or Consumer Guarantees Act 1993 (NZ). You are entitled to a replacement or refund for a major failure and compensation for any other reasonably foreseeable loss or damage. You are also entitled to have the goods repaired or replaced if the goods fail to be of acceptable quality and the failure does not amount to a major failure. This warranty excludes damage resulting from product misuse or product neglect, any modifications, additions or alterations to the product including the addition of extra shelves. Additions or modifications can compromise the structure and safety of the product. The warranty covers domestic use only and does not apply to commercial applications. This warranty is given by Pinnacle Hardware, ABN 87 614 496 196, 28 Hudson Court, Keysborough Vic 3173, 1800 349 776, Email: support@pinnacle.net.au. Products sold in New Zealand are imported by Bunnings New Zealand. 'Pinnacle' is a trademark © Pinnacle Hardware. Suitable for model number GOS092.

TIP OVER PREVENTION KIT:

PLEASE NOTE: We strongly recommend that this product is permanently fixed to a wall. Please use the provided “Tip over prevention kit” to securely fix product to your wall.

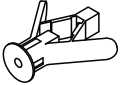

Parts list:

			
A x2	B x2	C x2	D x2

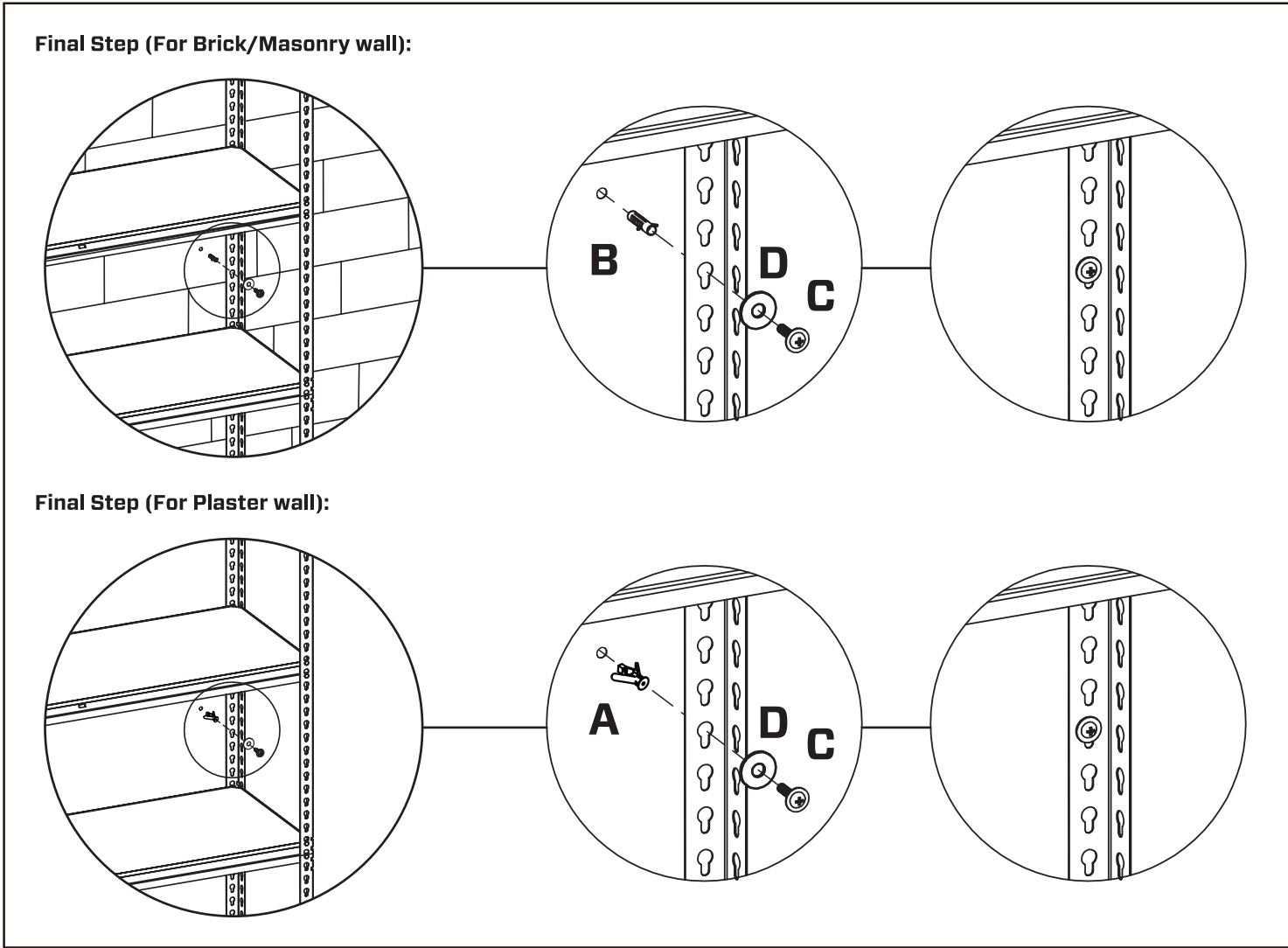

It is STRONGLY RECOMMENDED that you ANCHOR this product.

Toppling furniture can cause serious injuries and death. A “Tip over prevention kit” has been provided with this product to stop your furniture from tipping forward, it is strongly recommended that you **securely attach this product** to a wall or other solid surface using the provided fixings.

IMPORTANT: Regularly check that anchors are securely maintained. Stability of tall items may be affected by thick pile carpet or uneven floors.

- CAUTION:**
- For your safety when attaching the anchor fixings, please note the following:
- Check for any electrical wires or plumbing inside the wall before drilling any holes (if you are unsure please seek professional advice from a qualified tradesperson)
 - Walls are constructed from different materials, for example, masonry (solid brick) or plasterboard lined cavity walls (hollow). It is important that you use the appropriate wall fixings for your wall type.