



Electric Log Splitter

7 TON



OWNER'S MANUAL

Please read these instructions carefully before assembly.

Keep the instructions in a safe place for future use.

CONTENTS	
SYMBOLS IN THIS OWNER'S MANUAL	3
SYMBOLS ON THE MACHINE	3
PROPER USE	3
SAFETY PRECAUTIONS	3
UNDERSTAND YOUR LOG SPLITTER.....	3
DRUGS, ALCOHOL AND MEDICATION.....	3
AVOID DANGEROUS CONDITIONS.....	3
INSPECT YOUR LOG SPLITTER.....	3
DRESS PROPERLY.....	3
PROTECT YOUR EYES AND FACE.....	3
KEEP BYSTANDERS AND CHILDREN AWAY.....	4
AVOID INJURY FROM UNEXPECTED ACCIDENT.....	4
PROTECT YOUR HANDS.....	4
DON'T FORCE TOOL.....	4
INSPECT YOUR LOG.....	4
DON'T OVERREACH.....	4
NEVER LEAVE TOOL RUNNING UNATTENDED.....	4
DISCONNECT POWER.....	4
PROTECT THE ENVIRONMENT.....	4
MAINTAIN YOUR LOG SPLITTER WITH CARE.....	4
MAKE THE WORKSHOP CHILDPROOF.....	4
APPLICATION CONDITIONS	4
ELECTRICAL REQUIREMENTS.....	4
ASSEMBLY	4
OPERATION	5
FREEING A JAMMED LOG	6
REPLACING HYDRAULIC OIL	6
SHARPENING THE WEDGE	6
TROUBLESHOOTING	7
SPECIFICATIONS	7



Do not operate this machine before it has been assembled correctly and you have read and understood these instructions.



These instructions are intended as a general guide and do not supersede national or local codes in any way. Contact local Authorities for clarity of laws relating to operation of this appliance.

Keep the instructions in a safe place for future use.

SYMBOLS IN THIS OWNER'S MANUAL



Possible hazard or hazardous situation. Not observing this instruction can lead to injuries or cause damage to property.



Important information on proper handling. Not observing this instruction can lead to faults in the machine.



User information. This information helps you to use all the functions correctly.

SYMBOLS ON THE MACHINE



Read and understand the owner's manual and labels affixed to the log splitter. Learn its application and limitations as well as the specific potential hazards peculiar to it.



PROPER USE

For safety reasons, the Log Splitters are not to be used by children, young people, or any other persons who are not acquainted with these directions for use.



Specific safety information Please read this safety information and the directions for use carefully and be sure to follow the instructions to the letter.



WARNING! Even though this machine has been designed to be safe in use, it is essential to follow the Safe Working instructions carefully to avoid accidents to persons or property. Particular hazards are the use of incorrect electrical connections or touching exposed electrical components.

SAFETY PRECAUTIONS

UNDERSTAND YOUR LOG SPLITTER

Read and understand the owner's manual and labels affixed to the log splitter. Learn its application and limitations as well as the specific potential hazards peculiar to it.

DRUGS, ALCOHOL AND MEDICATION

Do not operate the log splitter while under the influence of drugs, alcohol, or any medication that could affect your ability to use it properly.

AVOID DANGEROUS CONDITIONS

Put the log splitter on a 60 - 75cm high, stable, flat, and level work bench where there is plenty of room for handling. Bolt the log splitter to the work surface if it tends to slip, walk, or slide. Keep your work area clean and well lighted. Cluttered areas invites injuries. Do not use the log splitter in wet or damp areas or expose it to rain. Do not use it in areas where fumes from paint, solvents or flammable liquids pose a potential hazard.



INSPECT YOUR LOG SPLITTER

Check your log splitter before turning it on. Keep guards in place and in working order. Form a habit of checking to see that keys and adjusting wrenches are removed from tool area before turning it on. Replace damaged, missing or failed parts before using it.



DRESS PROPERLY

Do not wear loose clothing, gloves, neckties or jewelry (rings, wrist watches). They can be caught in moving parts. Protective electrically non conductive gloves and non-skid footwear are recommended when working. Wear protective hair covering to contain long hair, preventing it from get caught in machinery.e.



PROTECT YOUR EYES AND FACE

Any log splitter may throw foreign objects into the eyes. This can cause permanent eye damage. Always wear safety goggles. Everyday eyeglasses have only impact resistant lenses. They are not safety glasses. Do not put the log splitter on the ground for operations. This is awkward operating position that the operator has to bring his face close to the machine, and thus risks being struck by wood chips or debris.



WARNING! ELECTRICAL SAFETY

- To avoid the risk of electric shock from the power cable, we strongly advise that the cable be plugged into a socket which has RCD protection.
- Long power cables will cause a drop in voltage, impairing the performance of the machine.
- Cables up to 10m long must have 2.5mm diameter.
- Ensure that the plug pins on the cable and the machine are not bent, and that the weight of the cable will not pull the socket apart.
- Do not separate the plug and socket by pulling on the cables.
- Check the condition of the power cable regularly for insulation damage, replacing if necessary.
- Do not bypass the safety switch on the cleaning flap retaining screw.



KEEP BYSTANDERS AND CHILDREN AWAY

The log splitter must be always operated by one person only. Other people should keep a safe distance from the work area, especially when the log splitter is in operation. Only one person at a time should try to free jammed logs.

INSPECT YOUR LOG

Make sure there are no nails or foreign objects in logs to be split. The ends of the logs must be cut square.

DON'T OVERREACH

Floor must not be slippery. Keep proper footing and balance at all times. Never stand on log splitter. Serious injury could occur if the tool is unintentionally contacted. Do not store anything above or near the log splitter where anyone might stand on it for reach.



AVOID INJURY FROM UNEXPECTED ACCIDENT

Always pay full attention to the movement of the log pusher. Do not attempt to load the log on until the log pusher has stopped. Keep hands out of the way of all moving parts.



PROTECT YOUR HANDS

Keep your hands away from splits and cracks which open in the log; They may close suddenly and crush or amputate your hands. Do not remove jammed logs with your hands.



DON'T FORCE TOOL

The Log Splitter will work better and safer within its designed parameters. Never try to split logs larger than those indicated in the specifications table. This could be dangerous and may damage the machine. Don't use log splitter for a purpose for which it was not intended.

NEVER LEAVE TOOL RUNNING UNATTENDED

Don't leave tool until it has come to a complete stop.



DISCONNECT POWER

Unplug when not in use, before freeing jammed logs, making adjustments, changing parts, cleaning, or working on the log splitter; Consult technical manual before servicing.



PROTECT THE ENVIRONMENT

Take used oil to an authorized collection point or follow the stipulations in the country where the log splitter is used. Do not discharge into drains, soil or water.

MAINTAIN YOUR LOG SPLITTER WITH CARE

Keep the log splitter clean for best and safest performance.

MAKE THE WORKSHOP CHILDPROOF

Lock the shop. Disconnect master switches. Store the log splitter away from children and others not qualified to use it. Children should not use the machine.

APPLICATION CONDITIONS

This log splitter is a **home use model**. It is designed for operating under ambient temperatures between +5°C and 40°C and for installation at altitudes no more than 1000m above M.S.L. The surrounding humidity should be less than 50% at 40°C. It can be stored or transported under ambient temperatures between -25°C and 55°C.

ELECTRICAL REQUIREMENTS

Connect the main leads to a standard 230V±10% (50HZ±1Hz) electrical supply which has protection devices of under-voltage, over-voltage, over-current as well as a residual current device (RCD) which maximum residual current rated at 0.03A.

ASSEMBLY

1. Bolt the Support Leg to the Log Splitter, lift the log splitter by the handles at both ends and place it on a 60 - 75cm high, stable, flat and level work surface.
2. Familiarise yourself with the controls and features of this log splitter in the illustrations.

1. Log Pusher
2. Work Table
3. Wedge
4. Lift Handle
5. Support Leg
6. Log Retaining Plates
7. Switch
8. Motor
9. Pushbutton Box
10. Wheels for Minor Moving Only
11. Hydraulic Control Lever
12. Control Lever Guard
13. Bleed Screw
14. Oil Drain Bolt w/ Dipstick
15. Max Pressure Limiting Screw

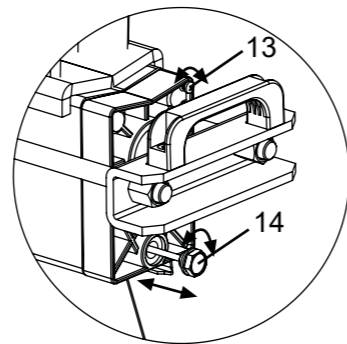
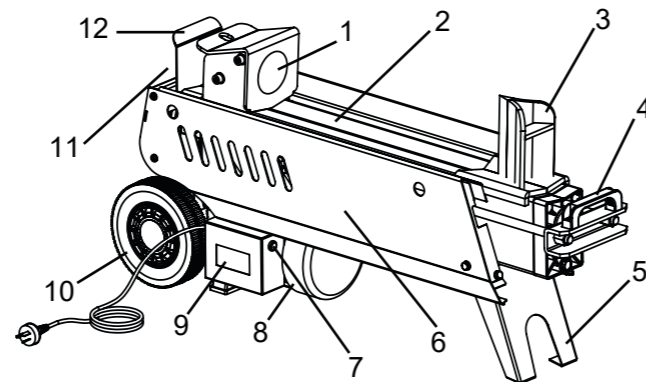

Important!

Before operating the log splitter, the Bleed Screw (13) should be loosened a few rotations until air can go in and out of the oil tank smoothly. Air flow through the Bleed Screw hole should be detectable while the log splitter is in use. Before moving the log splitter, make sure the Bleed Screw is tightened to avoid oil leaking from this point.



WARNING!

Failure to loosen the bleed screw will keep the sealed air in hydraulic system being compressed after being decompressed. Such continuous air compression and decompression will blow out the seals of the hydraulic system and cause permanent damage to the log splitter.



WARNING!

DO NOT ADJUST THE MAX PRESSURE LIMITING SCREW!

The max pressure limiting screw is sealed with glue to ensure the log splitter works under pressure no more than 7 tons. The setting was done by qualified mechanics with professional instruments.

Unauthorized resetting will cause the hydraulic pump fail to output enough splitting pressure or RESULT IN SERIOUS INJURY AS WELL AS DAMAGE TO THE MACHINE.

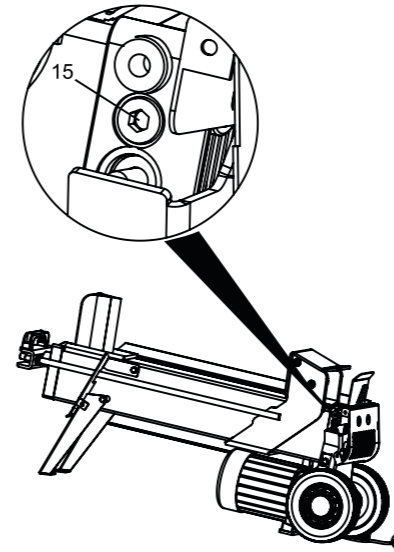

WIRING DIAGRAM

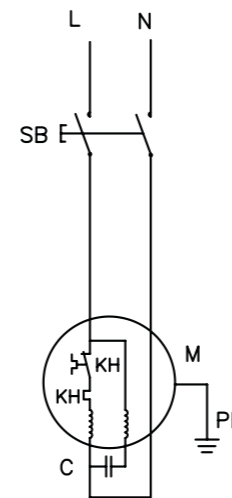

PLUMBING DIAGRAM

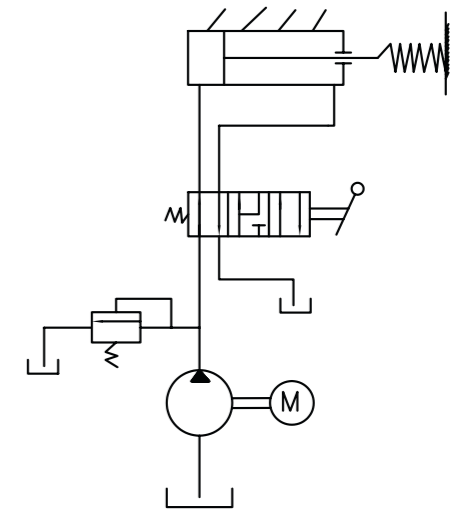

OPERATION

This log splitter is equipped with "ZHB" control system that requires it to be operated by both hands of the user - Left hand controls the hydraulic control lever while right hand controls the push button switch. The log splitter will freeze upon absence of either hand. Only after both hands release the controls, the log pusher starts to return backward to the starting position.

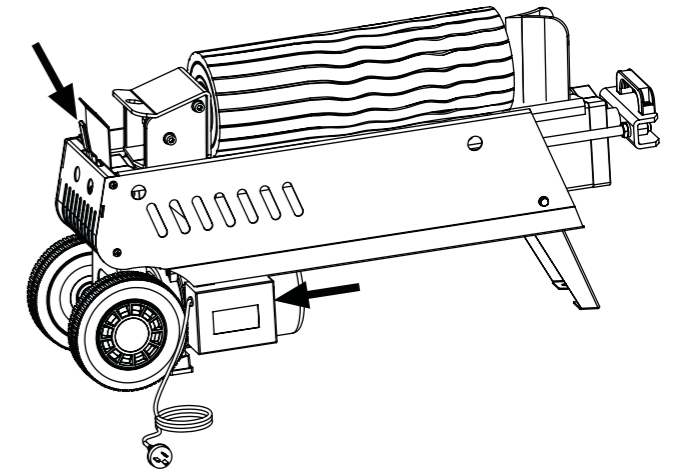

The splitting force and speed are governed by the 2-stage control lever. Push the lever in the 1st stage about half way for faster speed at less splitting force to split usual logs; Push the lever in the 2nd stage all way for maximum splitting force at slower speed to split particularly hard and seasoned logs. These stages can be shifted by simply raising and lowering the lever.



WARNING!

Never force the log splitter for more than 5 seconds by keeping pressure on it to split excessively hard wood.

After this time interval, the oil under pressure will be overheated and the machine could be damaged. For such extremely hard log, rotate it by 90° to see whether it can be split in a different direction. In any case, if you are not able to split the log, this means that its hardness exceeds the capacity of the machine and thus that log should be discarded to protect the log splitter.



WARNING!

Always set logs firmly on the log retaining plates and work table. Make sure logs will not twist, rock or slip while being split. Do not force the blade by splitting the log on the upper part. This will break the blade or damage the machine.

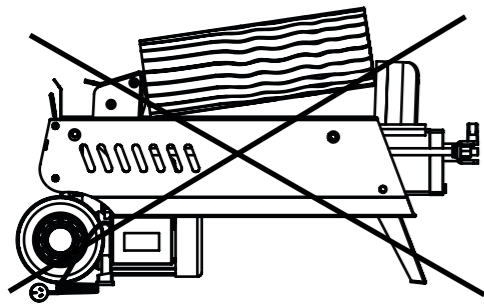

Important!

Break log in the direction of its growing grain. Do not place log across the log splitter for splitting. It may be dangerous and may seriously damage the machine. Do not attempt to split two pieces of logs at the same time. One of them may fly up and hit you.

FREEING A JAMMED LOG

- Release both controls.
- After the log pusher moves back and completely stops at its starting position, insert a wedge of wood under the jammed log.
- Start the log splitter to push the wedge further under the jammed piece lifting it.
- Repeat above procedure with a sharper slope wedge of wood until the log becomes completely free.

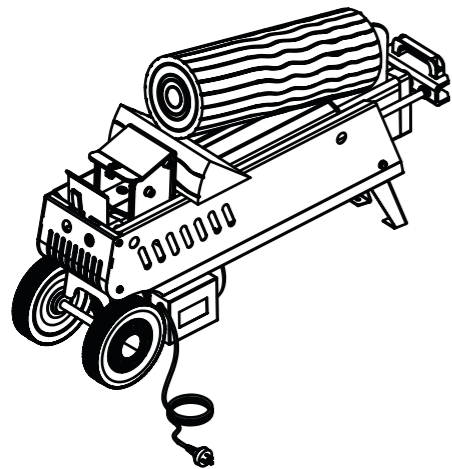

Important!

Do not try to knock the jammed log off. Knocking about will damage the machine or may launch the log and cause accident.

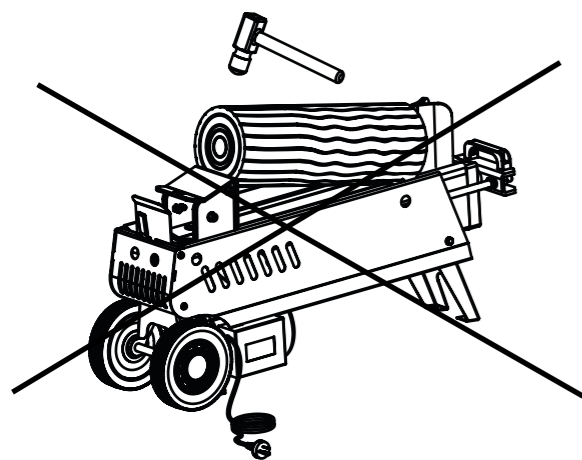

REPLACING HYDRAULIC OIL

Replace the Hydraulic oil in the log splitter after every 400 hours of use. Take following steps to replace it.

- Make sure all moving parts stops and the log splitter is unplugged.
- Unscrew Oil Drain Bolt with Dipstick to remove it.
- Turn the log splitter on the support leg side over a 8litre capacity container to drain the hydraulic oil off.
- Turn the log splitter on the motor side.
- Refill fresh hydraulic oil at the volume as per the hydraulic oil capacity of a particular model indicated in above specifications table.
- Clean the surface of dipstick on the oil drain bolt and put it back into the oil tank while keeping the log splitter vertical
- Make sure the level of the refilled oil is just between 2 grooves around the dipstick.
- Clean the oil drain bolt before threading back. Make it's tightened to avoid leakage before placing the log splitter horizontally.

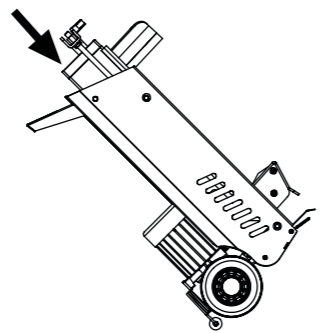
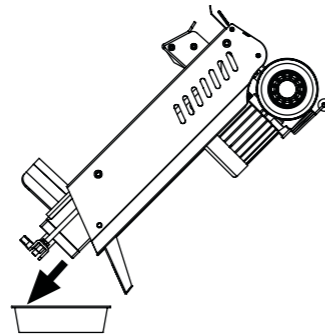

Important!

Periodically check oil level to ensure it is between 2 grooves around the Dipstick. Upon Lower oil level, oil refilling is required.

Following hydraulic oils or equivalent are recommend for the log splitter's hydraulic transmission system:

Any hydraulic fluid sold from a hardware or automotive supply stores. For example:

- SHELL Tellus 22.
- MOBIL DTE 11
- ARAL Vitam GF 22
- BP Energol HLP-HM 22

SHARPENING THE WEDGE

After using the log splitters for some time, sharpen the wedge of the log splitter using a fine-toothed file and smooth any burrs or crushed area along the cutting edge.

SERIAL NUMBER LOCATION



Serial Number Location
Example: 11 02 1022TP1690 0005

TROUBLESHOOTING

PROBLEM	PROBABLE	CAUSE REMEDY SUGGESTED
Fails to split logs	Log is improperly positioned.	Refer to 'Log Splitter Operation' section for perfect log loading.
	The sizes or hardness of the log exceeds capacity of the machine.	Reduce the log sizes before splitting it on the log the splitter.
	Wedge cutting edge is blunt	Refer to 'Sharpening Wedge' section to sharpen cutting wedge.
	Oil leaks	Locate leak(s) and contact the dealer.
The log pusher moves jerkily, making unfamiliar noises and vibrations	Unauthorized adjustment was made on Max. Pressure Limiting Screw. Lower max pressure rating was set.	Contact the dealer.
	Lack of hydraulic oil and excessive air in the hydraulic system.	Check oil level for possible oil refilling. Contact the dealer.
Oil leaks around log splitter or from other points.	Air sealed In hydraulic system while operating	Loosen Bleed Screw by 3 - 4 rotations before operating the log splitter.
	Bleed Screw was not tightened before moving cylinder ram or from the log splitter.	Tighten the Bleed Screw up before moving.
	Oil Drain Bolt with Dipstick is not tight.	Tighten the Oil Drain Bolt with Dipstick.
	Hydraulic Control Valve Assembly and / or seal(s) worn.	Contact the dealer.

SPECIFICATIONS

Model Number		WS7T
Motor - All		2300W S6 40% IP54 230V ~ 50Hz
Log Capacity	Diameter *	5 ~ 320mm
	Length	520mm
Splitting Force		7t
Hydraulic Pressure		16Mpa
Hydraulic Oil Capacity		6.5L
Overall Size	Length	1060mm
	Width	278mm
	Height	522mm
Weight		78kg

* The diameter of the log is indicative— a small log can be difficult to split when it has knobs or a particularly tough fibre. On the other hand, it may not be difficult to split logs with regular fibres even if its diameter exceeds the max. Figure indicated above.

