

RYOBI®

RMS305DB

ORIGINAL INSTRUCTIONS

Dual Bevel Sliding Mitre Saw



Important!

It is essential that you read the instructions in this manual before assembling, operating and maintaining the product.

Subject to technical modification.

Safety, performance, and dependability have been given top priority in the design of your mitre saw.

INTENDED USE

The mitre saw is intended for sawing solid and bonded wood, materials similar to wood, with or without glued veneer and plastics.

The mitre saw is intended to be used only by adult operators who have read the instruction manual and understand the risks and hazards.

The mitre saw is designed to be fixed at the base to either a solid bench top, or a dedicated mitre saw stand. If the base is not securely fixed, the whole machine may move during cutting operations, which increases the possibility of serious personal injury.

The mitre saw is designed to make bevel and mitre cuts. The capacities for the various cuts are provided in the product specifications in this manual.

The mitre saw is to be used in dry conditions, with excellent ambient lighting and adequate ventilation.

The mitre saw is intended for consumer use and should only be used as described above and is not intended for any other purpose.

GENERAL POWER TOOL SAFETY WARNINGS

WARNING

Read all safety warnings, instructions, illustrations and specifications provided with this power tool. Failure to follow all instructions listed below may result in electric shock, fire and/or serious injury.

Save all warnings and instructions for future reference. The term "power tool" in the warnings refers to your mains-operated (corded) power tool or battery-operated (cordless) power tool.

WORK AREA SAFETY

- **Keep work area clean and well lit.** Cluttered or dark areas invite accidents.
- **Do not operate power tools in explosive atmospheres, such as in the presence of flammable liquids, gases or dust.** Power tools create sparks which may ignite the dust or fumes.
- **Keep children and bystanders away while operating a power tool.** Distractions can cause you to lose control.

ELECTRICAL SAFETY

- **Power tool plugs must match the outlet. Never modify the plug in any way. Do not use any adapter plugs with earthed (grounded) power tools.** Unmodified plugs and matching outlets will reduce risk of electric shock.
- **Avoid body contact with earthed or grounded surfaces, such as pipes, radiators, ranges and refrigerators.** There is an increased risk of electric shock if your body is earthed or grounded.
- **Do not expose power tools to rain or wet conditions.**

Water entering a power tool will increase the risk of electric shock.

- **Do not abuse the cord. Never use the cord for carrying, pulling or unplugging the power tool. Keep cord away from heat, oil, sharp edges or moving parts.** Damaged or entangled cords increase the risk of electric shock.
- **When operating a power tool outdoors, use an extension cord suitable for outdoor use.** Use of a cord suitable for outdoor use reduces the risk of electric shock.
- **If operating a power tool in a damp location is unavoidable, use a residual current device (RCD) protected supply.** Use of an RCD reduces the risk of electric shock.

PERSONAL SAFETY

- **Stay alert, watch what you are doing and use common sense when operating a power tool. Do not use a power tool while you are tired or under the influence of drugs, alcohol or medication.** A moment of inattention while operating power tools may result in serious personal injury.
- **Use personal protective equipment. Always wear eye protection.** Protective equipment such as a dust mask, non-skid safety shoes, hard hat, or hearing protection used for appropriate conditions will reduce personal injuries.
- **Prevent unintentional starting. Ensure the switch is in the off -position before connecting to power source and/or battery pack, picking up or carrying the tool.** Carrying power tools with your finger on the switch or energising power tools that have the switch on invites accidents.
- **Remove any adjusting key or wrench before turning the power tool on.** A wrench or a key left attached to a rotating part of the power tool may result in personal injury.
- **Do not overreach. Keep proper footing and balance at all times.** This enables better control of the power tool in unexpected situations.
- **Dress properly. Do not wear loose clothing or jewellery. Keep your hair and clothing away from moving parts.** Loose clothes, jewellery or long hair can be caught in moving parts.
- **If devices are provided for the connection of dust extraction and collection facilities, ensure these are connected and properly used.** Use of dust collection can reduce dust-related hazards.
- **Do not let familiarity gained from frequent use of tools allow you to become complacent and ignore tool safety principles.** A careless action can cause severe injury within a fraction of a second.

POWER TOOL USE AND CARE

- **Do not force the power tool. Use the correct power tool for your application.** The correct power tool will do the job better and safer at the rate for which it was designed.
- **Do not use the power tool if the switch does not turn it on and off.** Any power tool that cannot be controlled with the switch is dangerous and must be repaired.



- **Disconnect the plug from the power source and/or remove the battery pack, if detachable, from the power tool before making any adjustments, changing accessories, or storing power tools.** Such preventive safety measures reduce the risk of starting the power tool accidentally.
- **Store idle power tools out of the reach of children and do not allow persons unfamiliar with the power tool or these instructions to operate the power tool.** Power tools are dangerous in the hands of untrained users.
- **Maintain power tools and accessories. Check for misalignment or binding of moving parts, breakage of parts and any other condition that may affect the power tool's operation. If damaged, have the power tool repaired before use.** Many accidents are caused by poorly maintained power tools.
- **Keep cutting tools sharp and clean.** Properly maintained cutting tools with sharp cutting edges are less likely to bind and are easier to control.
- **Use the power tool, accessories and tool bits etc. in accordance with these instructions, taking into account the working conditions and the work to be performed.** Use of the power tool for operations different from those intended could result in a hazardous situation.
- **Keep handles and grasping surfaces dry, clean and free from oil and grease.** Slippery handles and grasping surfaces do not allow for safe handling and control of the tool in unexpected situations.

SERVICE

- **Have your power tool serviced by a qualified repair person using only identical replacement parts.** This will ensure that the safety of the power tool is maintained.

SAFETY INSTRUCTIONS FOR MITRE SAWS

- **Mitre saws are intended to cut wood or wood-like products, they cannot be used with abrasive cut-off wheels for cutting ferrous material such as bars, rods, studs, etc.** Abrasive dust causes moving parts such as the lower guard to jam. Sparks from abrasive cutting will burn the lower guard, the kerf insert and other plastic parts.
- **Use clamps to support the workpiece whenever possible. If supporting the workpiece by hand, you must always keep your hand at least 100 mm from either side of the saw blade. Do not use this saw to cut pieces that are too small to be securely clamped or held by hand.** If your hand is placed too close to the saw blade, there is an increased risk of injury from blade contact.
- **The workpiece must be stationary and clamped or held against both the fence and the table. Do not feed the workpiece into the blade or cut "freehand" in any way.** Unrestrained or moving workpieces could be thrown at high speeds, causing injury.
- **Push the saw through the workpiece. Do not pull the saw through the workpiece. To make a cut, raise the saw head and pull it out over the workpiece without cutting, start the motor, press the saw head down and push the saw through the workpiece.** Cutting on the pull stroke is likely to cause the saw blade to climb on top of the workpiece and violently throw the blade assembly towards the operator.
- **Never cross your hand over the intended line of cutting either in front or behind the saw blade.** Supporting the workpiece "cross handed" i.e. holding the workpiece to the right of the saw blade with your left hand or vice versa is very dangerous.
- **Do not reach behind the fence with either hand closer than 100 mm from either side of the saw blade, to remove wood scraps, or for any other reason while the blade is spinning.** The proximity of the spinning saw blade to your hand may not be obvious and you may be seriously injured.
- **Inspect your workpiece before cutting. If the workpiece is bowed or warped, clamp it with the outside bowed face toward the fence. Always make certain that there is no gap between the workpiece, fence and table along the line of the cut.** Bent or warped workpieces can twist or shift and may cause binding on the spinning saw blade while cutting. There should be no nails or foreign objects in the workpiece.
- **Do not use the saw until the table is clear of all tools, wood scraps, etc., except for the workpiece.** Small debris or loose pieces of wood or other objects that contact the revolving blade can be thrown with high speed.
- **Cut only one workpiece at a time.** Stacked multiple workpieces cannot be adequately clamped or braced and may bind on the blade or shift during cutting.
- **Ensure the mitre saw is mounted or placed on a level, firm work surface before use.** A level and firm work surface reduces the risk of the mitre saw becoming unstable.
- **Plan your work. Every time you change the bevel or mitre angle setting, make sure the adjustable fence is set correctly to support the workpiece and will not interfere with the blade or the guarding system.** Without turning the tool "ON" and with no workpiece on the table, move the saw blade through a complete simulated cut to assure there will be no interference or danger of cutting the fence.
- **Provide adequate support such as table extensions, saw horses, etc. for a workpiece that is wider or longer than the table top.** Workpieces longer or wider than the mitre saw table can tip if not securely supported. If the cut-off piece or workpiece tips, it can lift the lower guard or be thrown by the spinning blade.
- **Do not use another person as a substitute for a table extension or as additional support.** Unstable support for the workpiece can cause the blade to bind or the workpiece to shift during the cutting operation pulling you and the helper into the spinning blade.
- **The cut-off piece must not be jammed or pressed by any means against the spinning saw blade.** If confined, i.e. using length stops, the cut-off piece could get wedged against the blade and thrown violently.
- **Always use a clamp or a fixture designed to properly support round material such as rods or tubing.** Rods have a tendency to roll while being cut, causing the blade to "bite" and pull the work with your



hand into the blade.

- **Let the blade reach full speed before contacting the workpiece.** This will reduce the risk of the workpiece being thrown.
- **If the workpiece or blade becomes jammed, turn the mitre saw off. Wait for all moving parts to stop and disconnect the plug from the power source and/ or remove the battery pack. Then work to free the jammed material.** Continued sawing with a jammed workpiece could cause loss of control or damage to the mitre saw.
- **After finishing the cut, release the switch, hold the saw head down and wait for the blade to stop before removing the cut-off piece.** Reaching with your hand near the coasting blade is dangerous.
- **Hold the handle firmly when making an incomplete cut or when releasing the switch before the saw head is completely in the down position.** The braking action of the saw may cause the saw head to be suddenly pulled downward, causing a risk of injury.

SAFETY INSTRUCTIONS FOR WOOD CUTTING BLADE

- Please read the manual and instructions carefully before using the saw blade and the machine.
- The product must be in good condition, the spindle without deformation and vibration.
- Do not use the product without the guards in position. Keep guards in good working order and properly maintained.
- Ensure the operator is adequately trained in safety precautions, adjustment and operation of the product.
- Always wear goggles and ear protection when using the product. It is recommended to wear gloves, sturdy non slipping shoes and apron.
- Before using any accessory, consult the instruction manual. The improper use of an accessory can cause damage and increase the potential for injury.
- Use only blades specified in this manual, complying with EN 847-1.
- Observe the maximum speed marked on the saw blade. Ensure the speed marked on the saw blade is at least equal to the speed marked on the saw.
- Always use blades with correct size and shape of arbour holes. Blades that do not match the mounting hardware of the saw will run eccentrically, causing loss of control.
- Do not use blades of larger or smaller diameter than recommended. Do not use any spacers to make the blade fit onto the spindle.
- Check the tips of the saw blade for damage or abnormal appearance before each use. Tips that are damaged or loose can become flying objects in use and increase the chance of personal injury.
- Do not use cracked or distorted saw blades. Do not use saw blades that are damaged or deformed.
- Scrap the saw blade if damaged, deformed, distorted or cracked, repairing is not permitted.
- Do not use HSS blades.

- Ensure the saw blade is mounted correctly, tighten the arbor nut securely before use (tightening torque approx. 12-15 Nm).
- Fastening screw and nuts shall be tightened using the appropriate spanner, etc.
- Extension of the spanner or tightening using hammer blows is not permitted.
- Make sure the blade and flanges are clean and the recessed sides of the collar are against the blade.
- Make sure the blade rotates in the correct direction.
- Before work, make a dummy cut without the motor turned on so the position of the blade, operation of the guards with respect to other machine parts and workpiece may be checked.
- Never leave the product unattended.
- Do not apply lubricants on the blade when it is running.
- Never perform any cleaning or maintenance work when the machine is still running and the head is not in the rest position.
- Never attempt to stop a machine in motion rapidly by jamming a tool or other means against the blade, serious accidents can be caused unintentionally in this way.
- Disconnect the product from the mains supply or remove battery pack before changing blades or carrying out maintenance.
- Pay attention to blade packing and unpacking, it is easy to be injured by the sharp blade tips.
- Use a blade holder or wear gloves when handling a saw blade.
- Keep and store the blade in original packaging or other suitable packaging, keep in dry conditions and away from chemicals which may damage the blade.

ADDITIONAL SAFETY WARNINGS

- Always clamp the workpiece safely and securely.
- Ensure that the product is always stable and secure (e.g., fixed to a bench or mitre saw stand).
- Always wear ear protectors. Exposure to noise can cause hearing loss.
- Always wear safety goggles when using the product. It is recommended to wear gloves for handling blades and rough material, plus sturdy non slip shoes to protect the feet from workpieces which may fall from the cutting area.
- Disconnect the product from the mains supply or remove battery pack before carrying out any maintenance or cleaning the product.
- Only connect to the mains supply when the product is switched off.
- Never reach into the area near the blade unless the blade has completely stopped.
- Before use, thoroughly check the product, cable and plug for any damage or material fatigue. Repairs to the whole product should only be carried out by an authorised service centre.
- Always use the guards on the product. Do not use the product if the guards are not in place and working

correctly.

- The lower blade guard should only open when the blade is lowered to the workpiece and must always be able to move freely and close automatically.
- Always fix and use extension bars for workpiece support during operation.
- Never alter or modify the product or its function. Your safety may be compromised.
- Do not use saw blades which are cracked, damaged or deformed.
- Do not use saw blades made of high-speed steel.
- Only use blades that are sharp. Replace dull blades.
- Always use blades with correct size and shape of arbour holes. Blades that do not match the mounting hardware of the saw will run eccentrically, causing loss of control.
- Use only woodworking blades specified in this manual, which comply with EN 847-1.
- Do not use any flanges, washers and nuts to secure the saw blade other than those supplied or indicated in the instruction manual.
- It is necessary to select a saw blade which is suitable for the material being cut. Never use the product to cut materials other than those specified in the intended use section in this manual.
- It is important to avoid overheating the blade and melting the plastic workpiece when cutting.
- It is essential to adhere to the maximum speed specified on the saw blade, only use saw blade that are marked with a speed equal or higher than the speed marked on the tool.
- Replace the table insert when worn or damaged.
- Before work, make a dummy cut without the motor turned on so the position of the blade, operation of the guards with respect to other machine parts, and workpiece may be checked.
- When performing mitre, bevel or compound mitre cuts, adjust or remove the sliding fence to ensure the correct clearance from the blade. Sliding fence removal is required at bevel angle larger than 30° to the right and 30° to the left. Refer to page 15 for instructions of sliding fence adjustment and 21- 24 for removal respectively.
- After removal, the sliding fence must be well kept and reinstalled when bevel or compound mitre cut is complete.
- The bracket stop must always be engaged when transporting the product.
- Keep the floor area free of loose materials, such as chips and cut-offs.
- Refrain from removing any cut-offs or other parts of the workpiece from the cutting area whilst the product is running and the saw head is not in the rest position.
- Long workpieces must be adequately supported. The working area of the saw includes the whole extent of the workpiece. The operator should secure this area from accidental contact from other persons or objects which may move the workpiece during operation.
- The dust produced when using the product may be

harmful to health. Use a dust suction system and wear a suitable dust protection mask. Remove deposited dust thoroughly with a vacuum cleaner.

- Do not replace the laser with a different type. Any repairs must only be carried out by the manufacturer or authorised service agent.
- It is recommended that the product always be supplied via a residual current device having a rated residual current of 30 mA or less.
- When using the product, voltage fluctuations may affect other electrical products or lighting on the same power circuit. Connect the product to a power source with an impedance equal to 0.351 Ω to minimize voltage fluctuations. Contact your electric power supplier for further clarification.

LASER SAFETY RULES

- The laser radiation used in this saw is Class 2 with maximum $\leq 1\text{mW}$ and 650nm wavelengths. Do not stare into the laser beam. Failure to comply with the rules could result in serious personal injury.
- Do not stare into beam during operation.
- Do not project the laser beam directly into the eyes of others. Serious eye injury could result.
- Do not place the laser in a position that may cause anyone to stare into the laser beam intentionally or unintentionally.
- Do not use optical tools to view the laser beam.
- Do not operate the laser around children or allow children to operate the laser.
- Do not attempt to repair the laser device by yourself.
- Do not attempt to change any parts of the laser device by yourself.
- Any repairs must only be carried out by the laser manufacturer or authorized service agent.
- Do not replace the laser with a different type.

RESIDUAL RISKS

Even when the product is used as prescribed, it is still impossible to completely eliminate certain residual risk factors. The following hazards may arise and the operator should pay special attention to avoid the following:

- Risk of contact with uncovered parts of the rotating saw blade
 - Kick-back of workpieces or parts of workpieces due to improper adjustment or handling
 - Catapulting of faulty carbide tips from the saw blade
 - Damage to the respiratory system
- NOTE:** Wear respiratory protection masks containing filters appropriate to the materials being worked. Ensure adequate workplace ventilation. Do not eat, drink or smoke in the work area.
- Damage to hearing if effective hearing protection is not worn.

WARNING

Dust from certain paints, coatings and materials may cause irritation or allergic reactions to the respiratory system. Dust from wood such as oak, beech, MDF and others are carcinogenic. Material containing asbestos should only ever be worked or processed by qualified specialist operators.

WARNING

Injuries may be caused, or aggravated, by prolonged use of a tool. When using any tool for prolonged periods, ensure you take regular breaks.

MAINTENANCE

- Do not modify the product in any way or use accessories not approved by the manufacturer. Your safety and that of others may be compromised.
- Do not use the product if any switches, guards or other functions does not work as intended. Return to an authorised service centre for professional repair or adjustment.
- Do not make any adjustments whilst the saw blade is in motion.
- Always make sure the plug has been removed from the mains supply before making adjustments, lubricating or when doing any maintenance on the product.
- Before and after each use, check the product for damage or broken parts. Keep the product in top working condition by immediately replacing parts with spares approved by the manufacturer.
- The blade has sharp edges and may also remain hot after cutting operations. Exercise extreme caution when cleaning an exposed blade. Wear gloves to protect yourself from personal injury.
- Clean the saw and its accessories from dust regularly, especially moving parts including the blade guard. Use a hand brush or vacuum cleaner to remove dust effectively. Do not use compressed air.
- If the replacement of the supply cord is necessary, this has to be done by the manufacturer or his agent in order to avoid a safety hazard.
- To assure safety and reliability, all repairs, including changing brushes, should be performed by an authorised service centre.

LUBRICATION

- All of the bearings in the product are lubricated with a sufficient amount of high grade lubricant for the life span of the product under normal operating conditions. Therefore, no further lubrication is required.

WARNING

Do not attempt to disassemble the blade guard assembly for cleaning or repair. Damaged guards should not be used. Return to an authorised service centre for repair or replacement.

WARNING

For greater safety and reliability, all repairs should be performed by an authorised service centre.

Mitre and bevel angle calibration

If mitre and bevel angle calibration are needed, see pages 32 – 39 and follow the calibration instructions.

Maximum cutting depth stop

The maximum cutting depth stop is to prevent the saw blade from cutting into the metal base of the unit.

WARNING

The maximum cutting depth stop is not user-adjustable. Do not adjust the maximum cutting depth stop.

TRANSPORTATION AND STORAGE

- When storing the product, disconnect the power cord. Store the product in a secure place that is not accessible to children.
- Clean the product using a brush and vacuum cleaner before storage.
- If you remove the saw blade or keep spares with the unit, ensure they are in the original packaging to prevent injury.

To secure the product prior to movement:

- The product should be stored at the zero degree mitre and bevel angle and locked in position. The slide should be locked. The handle should be locked in the lower (safe) position with the guards closed.
- One or both sides of the extension bars can be removed for ease of carrying.

To move or transport in a vehicle:



















- Secure the product prior to movement as described in the manual.
- Remove the product from the bench top or mitre saw stand by releasing the 4 bolts, one at each corner. Secure the bolts for future use. Lifting the product using the handle at the top.
- When lifting to a height, two persons wearing heavy gloves are needed to lift the base of the product.
- When transporting in a vehicle, set the product on its base and secure against movement.

ENVIRONMENTAL PROTECTION

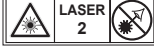

Recycle raw materials instead of disposing of as waste. The machine, accessories and packaging should be sorted for environmental-friendly recycling.

SYMBOLS ON THE PRODUCT

	Safety alert
	Regulatory Compliance Mark (RCM). Product meets applicable regulatory requirements.
	Please read the instructions carefully before starting the machine.
	Wear ear protection
	Always wear eye protection.
	Class II tool, double insulation
	Keep hands away from the cutting area and sharp blade.
	Do not expose to rain or use in damp locations.
	Wear safety gloves
	Blade rotation direction (shown on saw blade)
	Blade rotation direction (shown on blade guard)
	Blade width of cut (Kerf)
	Number of teeth on this saw blade
	Cutting capacity
	For cutting wood and analogous material
	Not for cutting metals
	Laser radiation. Do not stare into beam. Class 2 laser product
	Do not stare into beam.









Laser radiation.
Class 2 laser product
 λ : 650nm; $P \leq 1\text{mW}$
IEC 60825-1:2014

Waste electrical products should not be disposed of with household waste. Please recycle where facilities exist. Check with your Local Authority or retailer for recycling advice.



SYMBOLS IN THIS MANUAL

	Connect to power outlet.
	Disconnect from power outlet.
	Lock
	Unlock
	Parts or accessories sold separately
	Note
	Warning

The following signal words and meanings are intended to explain the levels of risk associated with this product:

DANGER

Indicates an imminently hazardous situation, which, if not avoided, will result in death or serious injury.

WARNING

Indicates a potentially hazardous situation, which, if not avoided, could result in death or serious injury.

CAUTION

Indicates a potentially hazardous situation, which, if not avoided, may result in minor or moderate injury.

CAUTION

(Without Safety Alert Symbol) Indicates a situation that may result in property damage.

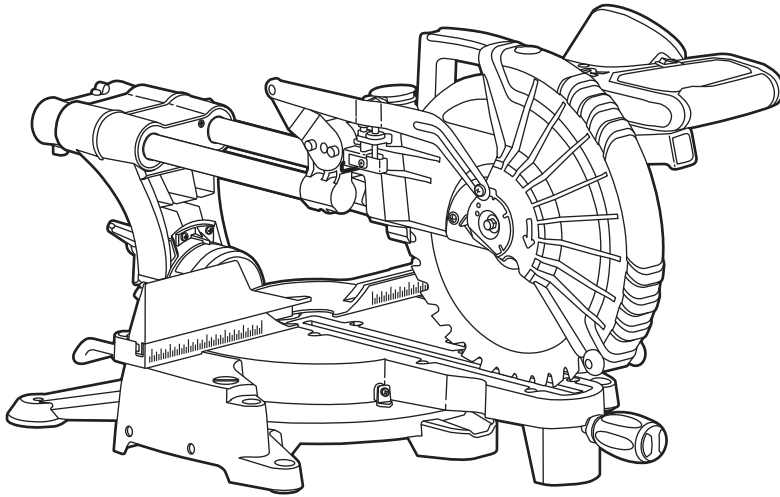

x 1

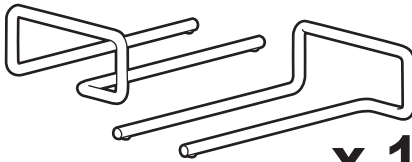

x 1

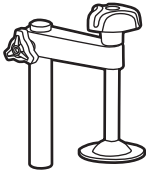

x 1

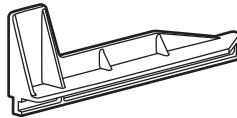

x 1

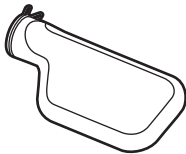







x 1

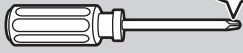

x 1

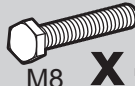



 2 mm  4 mm
 5 mm  M8
x 4
 M8 **x 4**  **x 8**
D13 x D8
x 1.6mm

1. Handle, insulated gripping surface
2. Power switch
3. Safety lock lever
4. Upper guard
5. Lower guard
6. Sliding fence x 2
7. Main fence x 2
8. Turntable
9. Base
10. Table insert
11. Turntable lock handle
12. Balancing foot
13. Carrying handle
14. Dust bag
15. Cutting depth adjustment knob
16. Maximum cutting depth stop
17. Laser assembly
18. Clamp

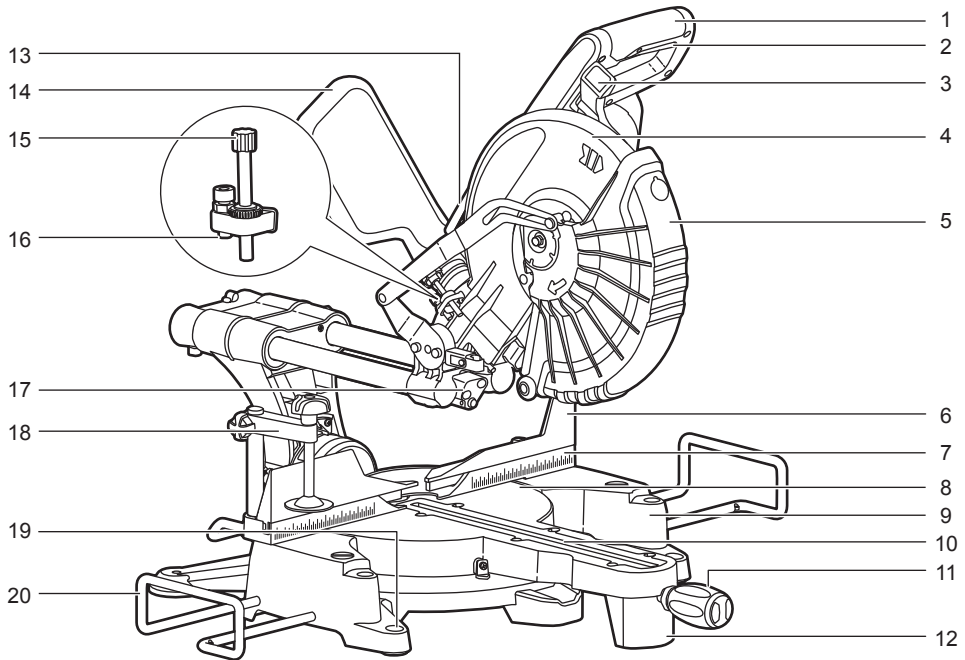
19. Mounting hole x 4
20. Workpiece support x 2
21. Blade
22. Laser switch
23. Spindle lock button
24. Bracket stop
25. Linear rod stop knob
26. Screws for locking main fence
27. Sliding fence lock knob
28. Bevel angle lock knob
29. Screws for adjusting the bevel angle limit stop
30. Bevel angle lock pin
31. Rear support

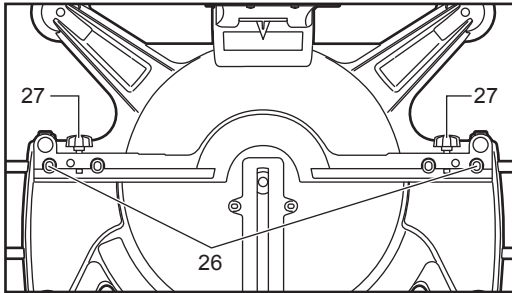
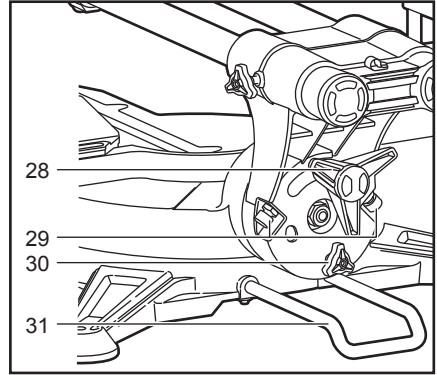
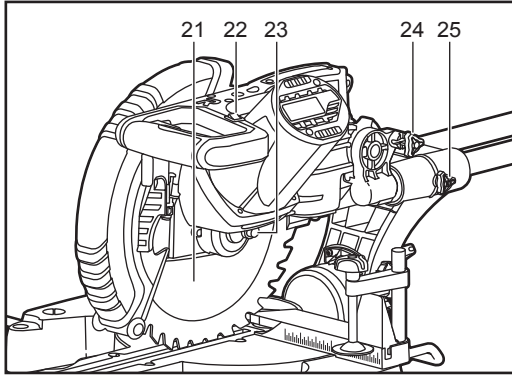

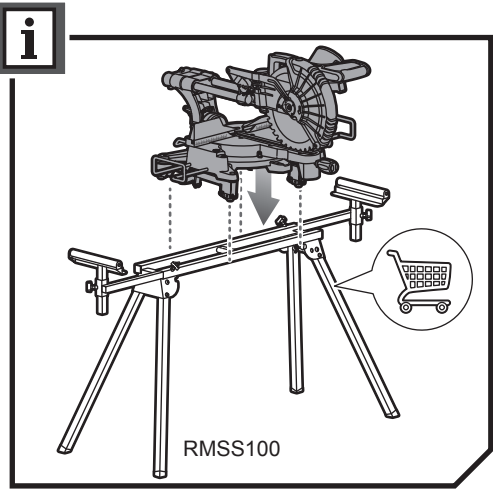
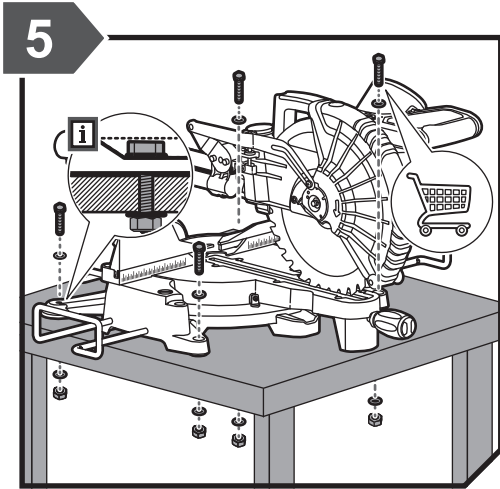
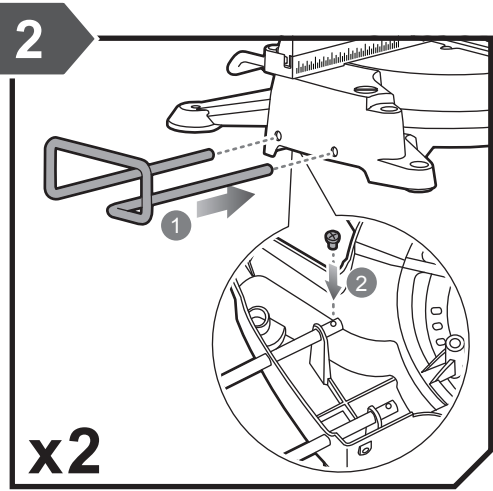
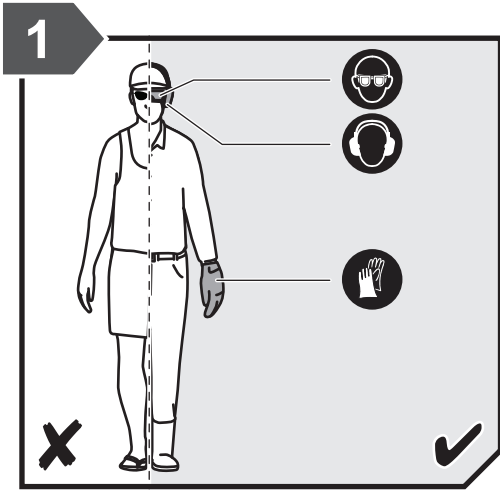



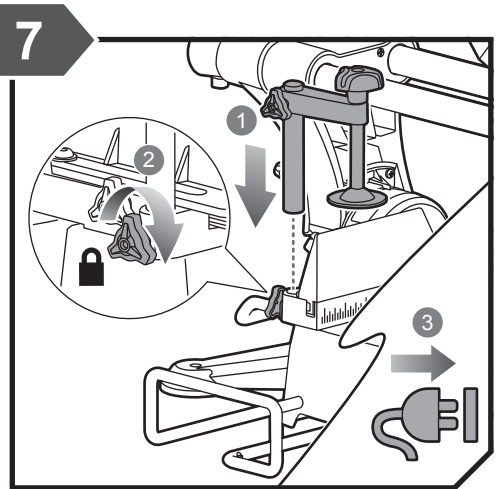
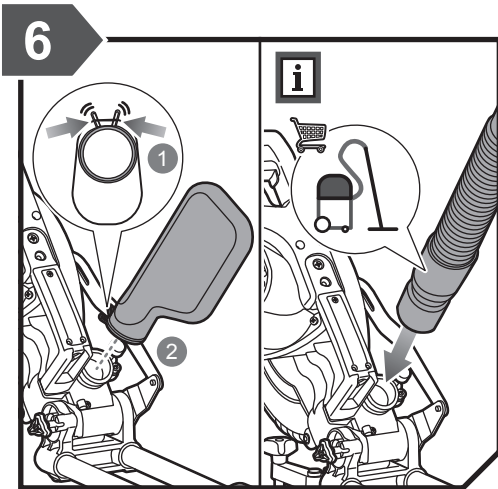
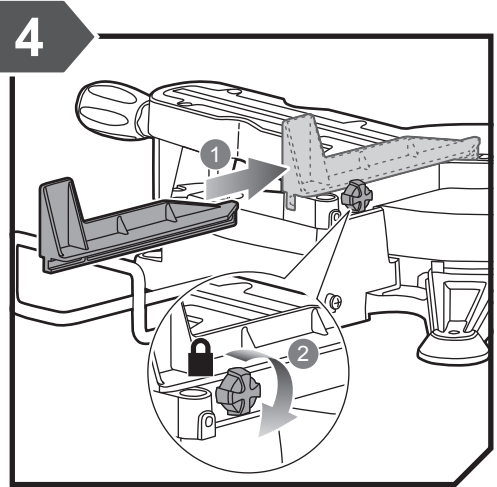
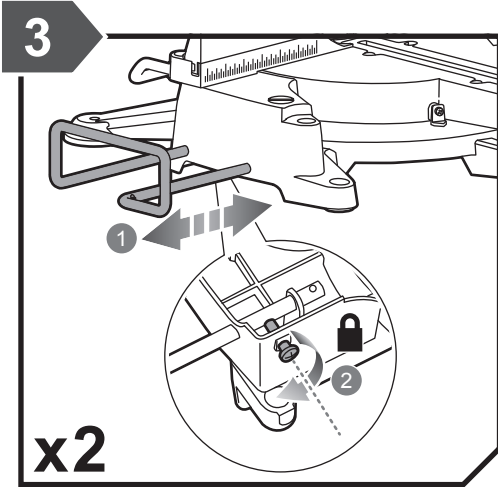

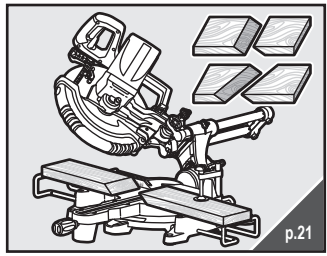
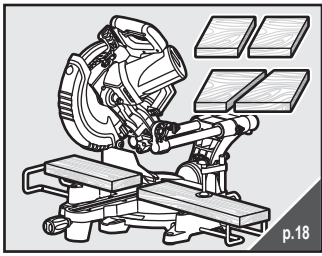
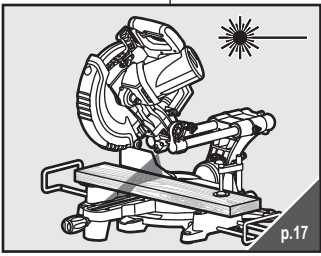
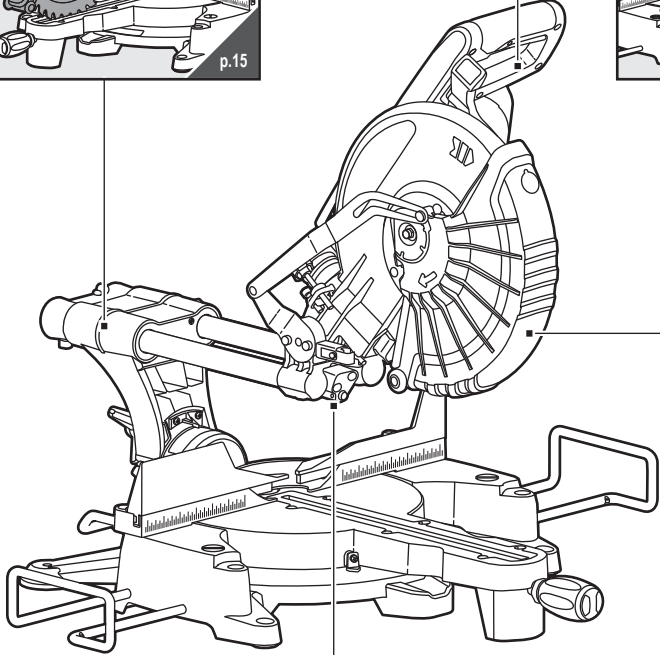
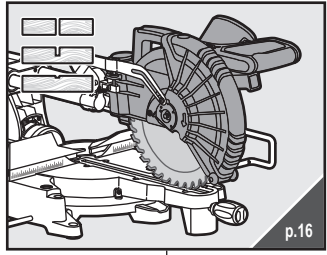
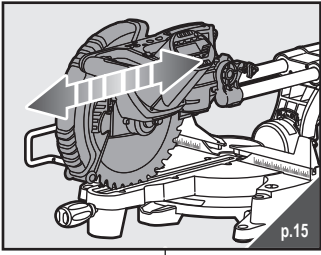
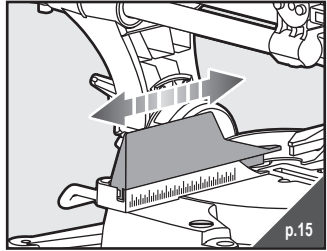
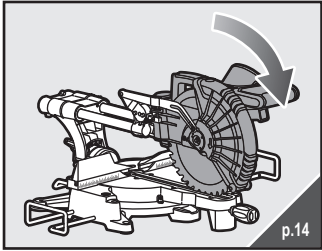
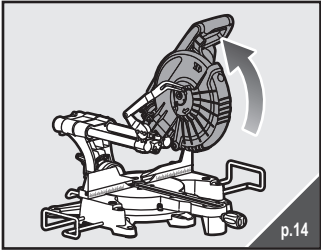

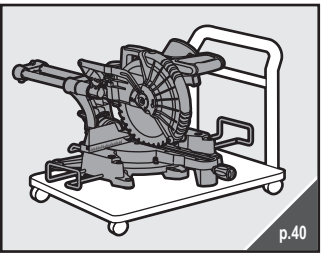
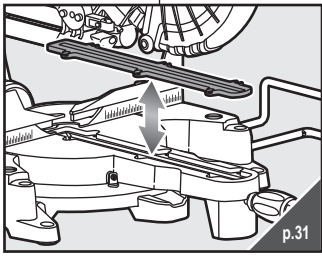
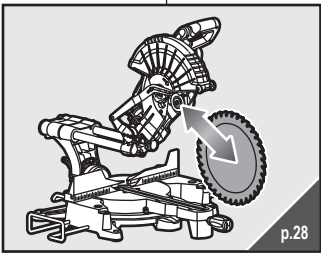
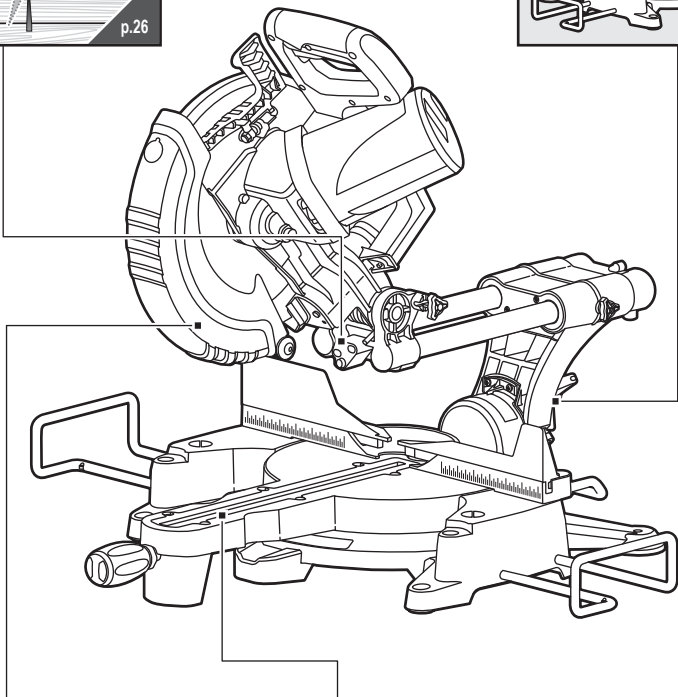
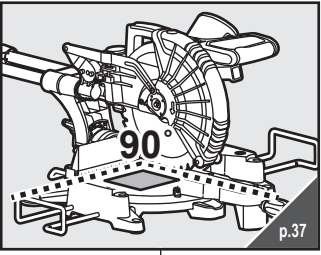
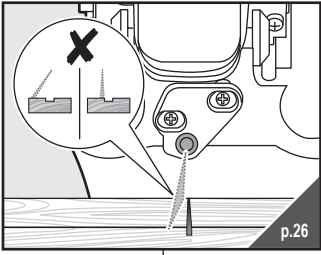
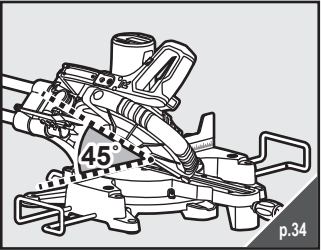
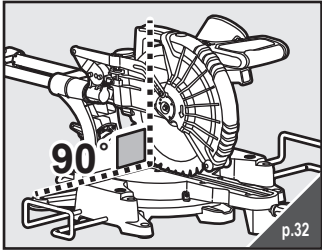
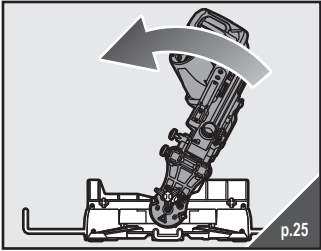

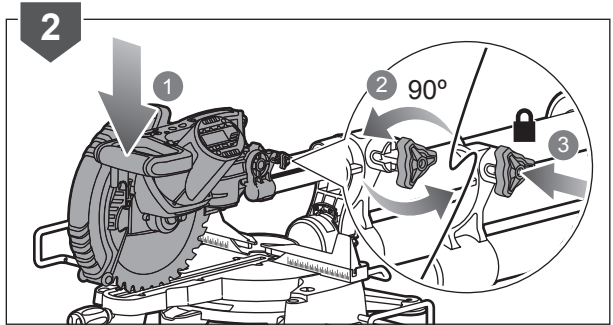
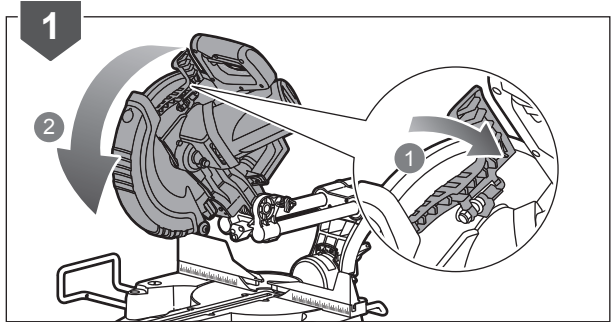
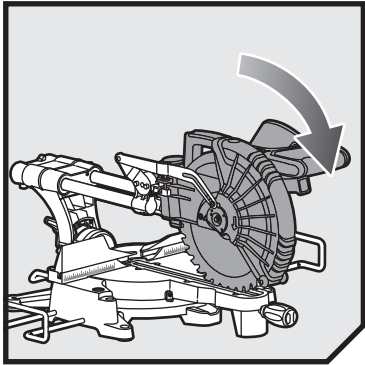
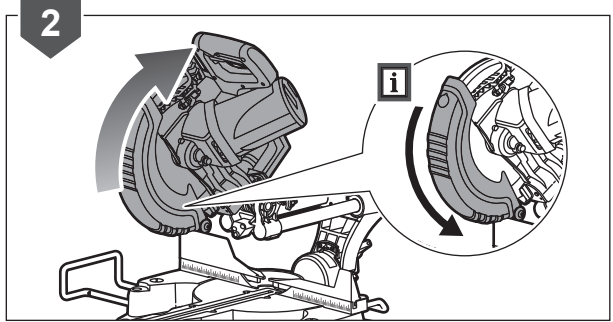
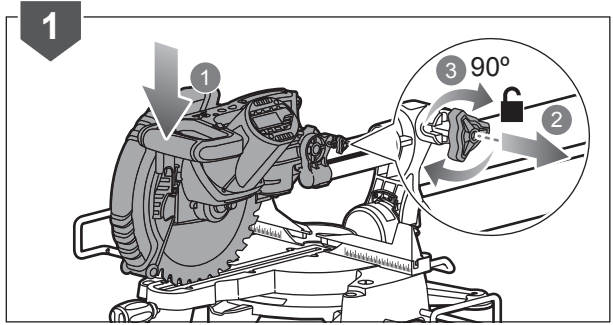
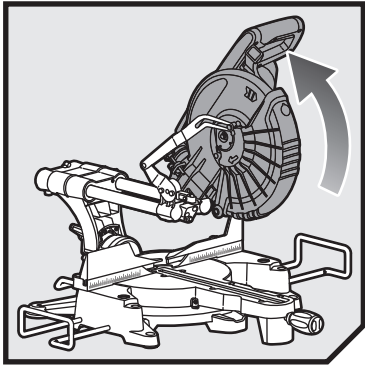

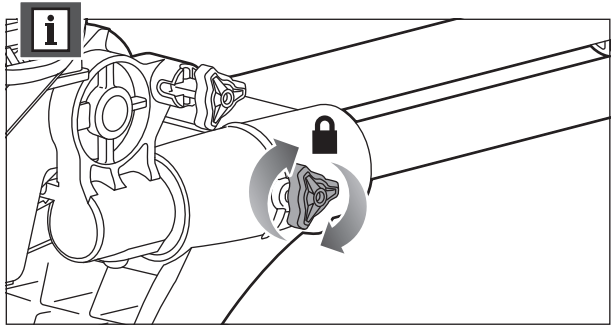
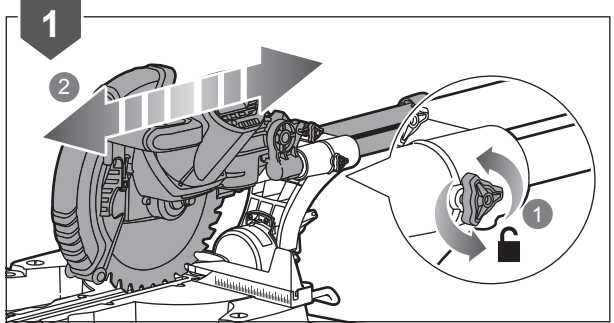
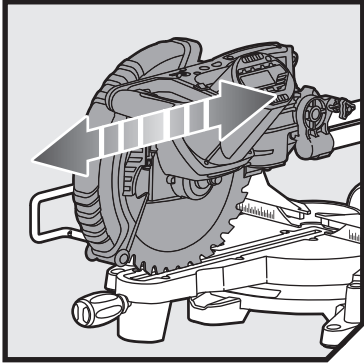
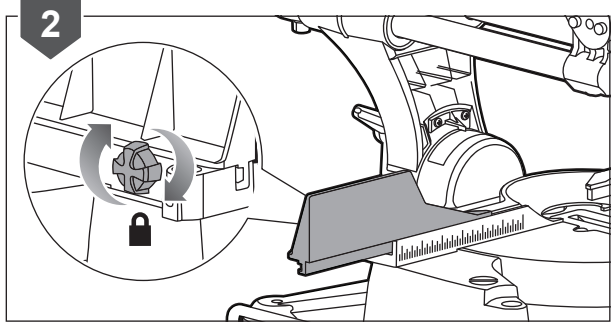
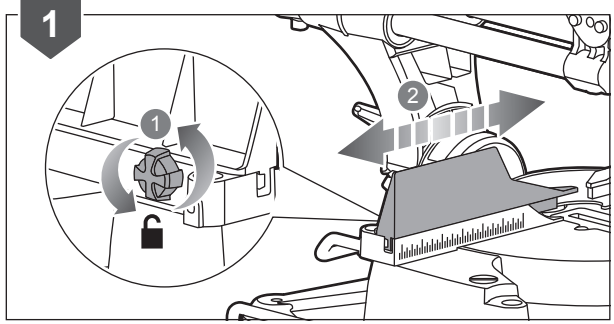
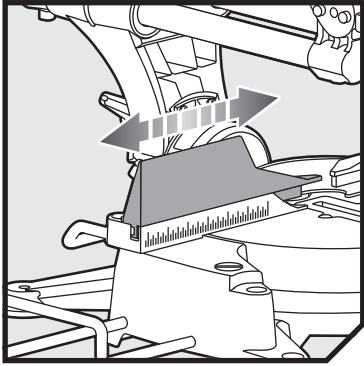

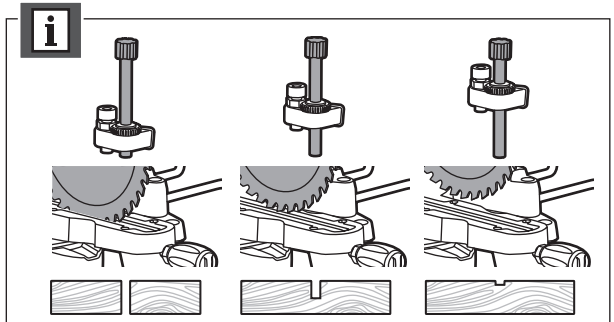
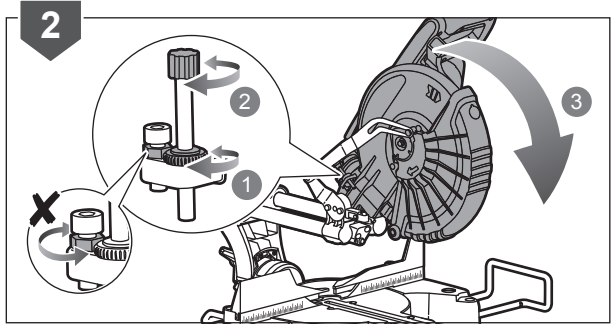
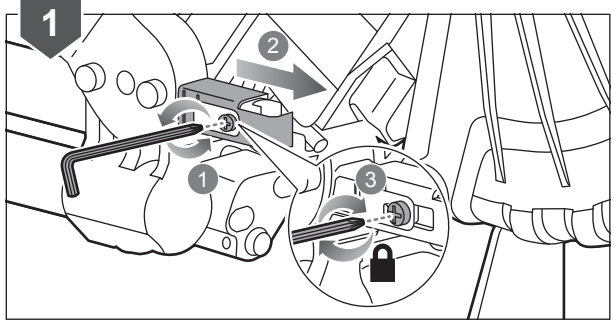
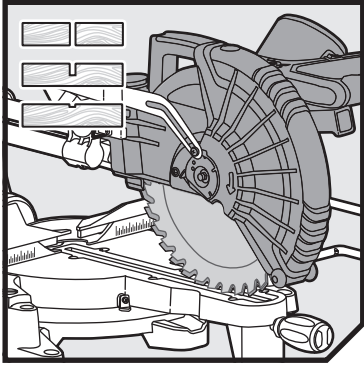

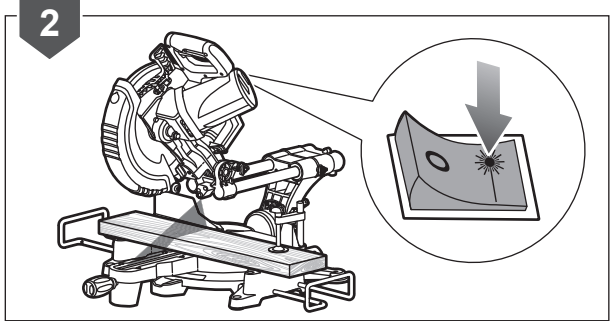
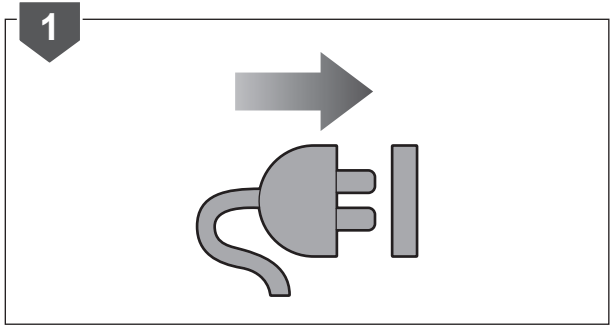
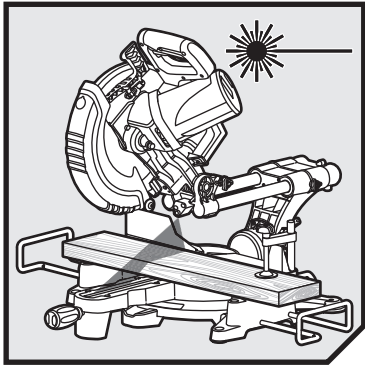

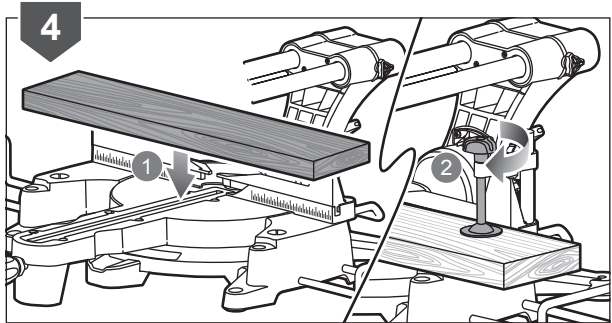
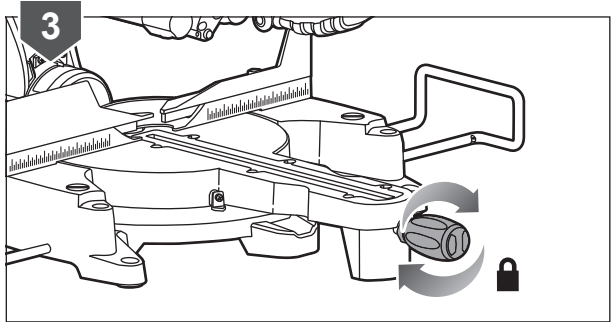
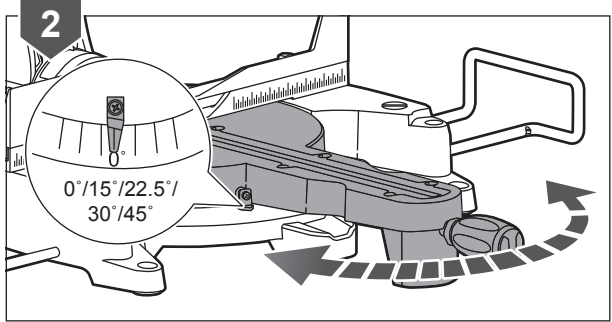
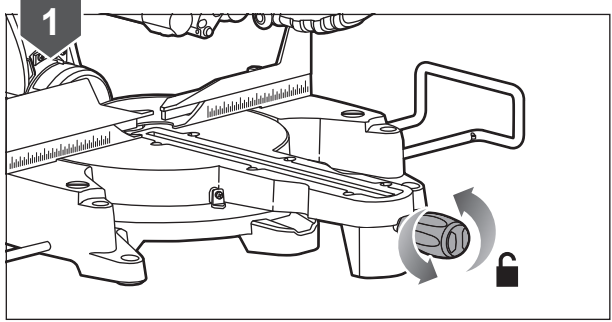
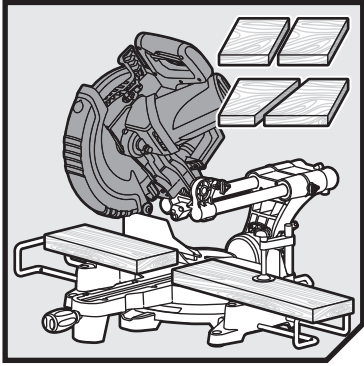

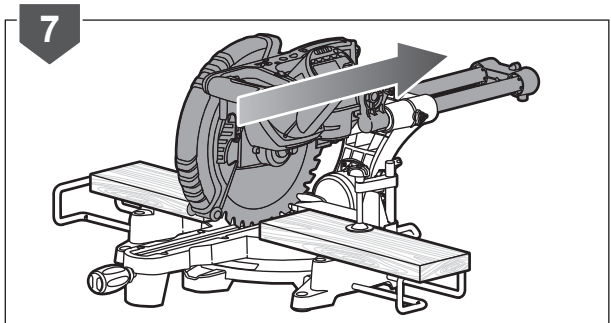
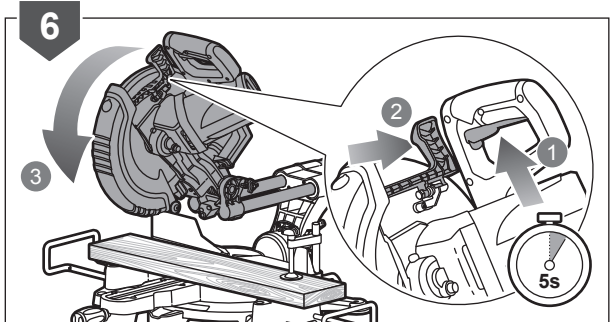
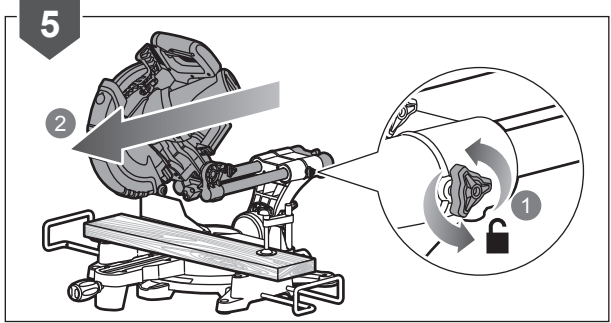
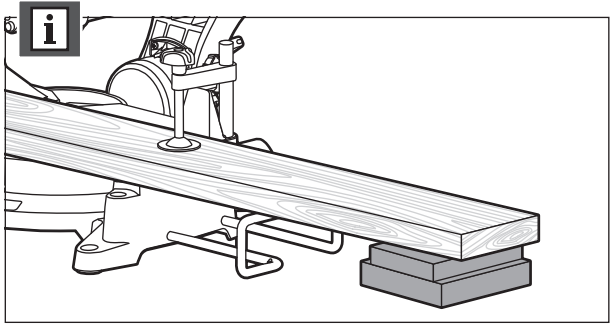

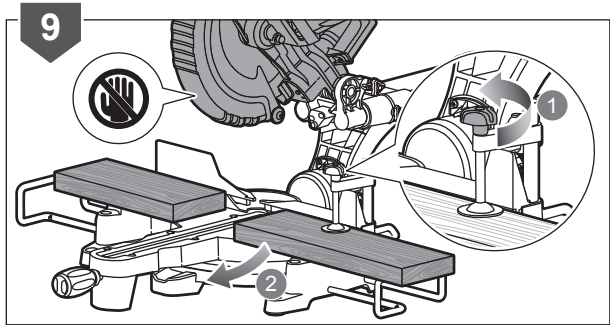
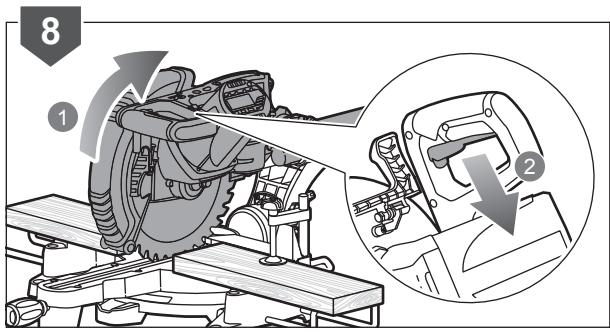

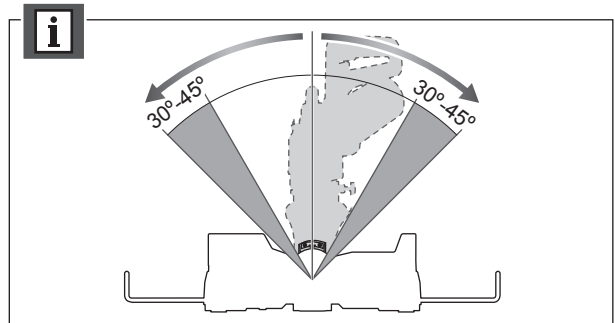
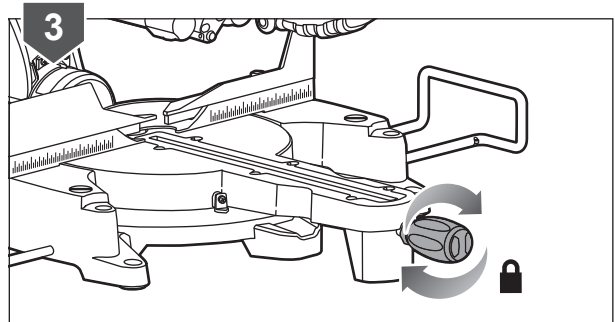
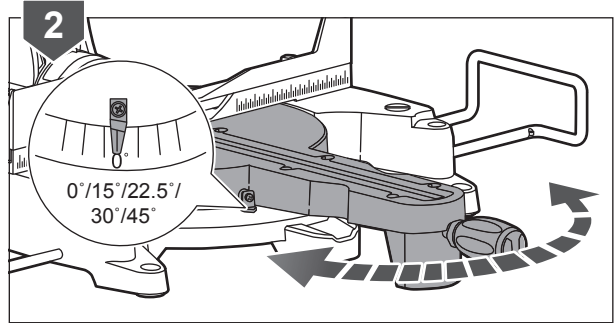
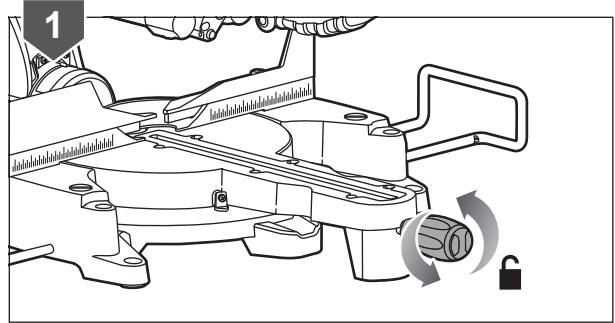
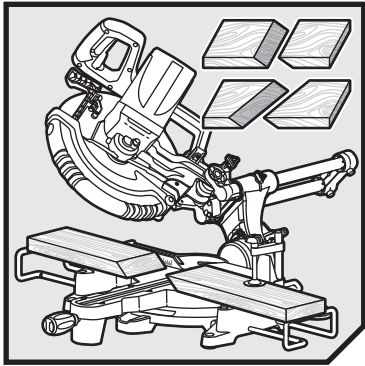

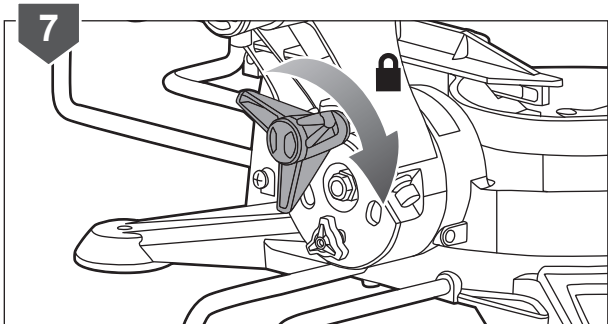
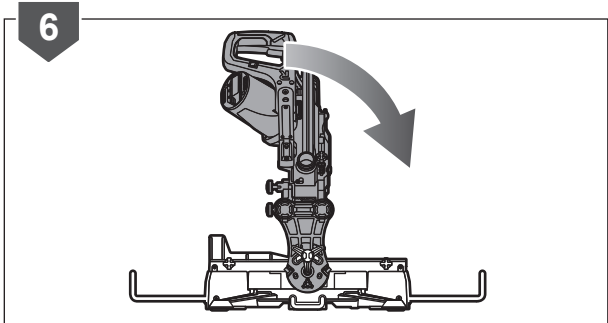
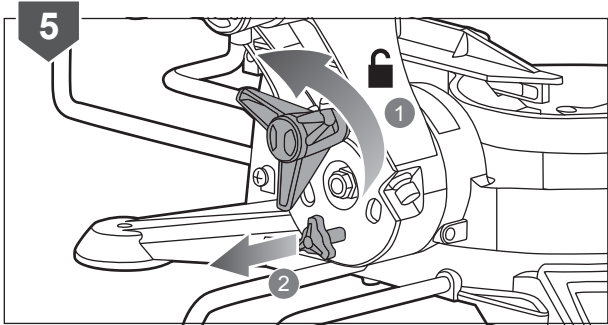
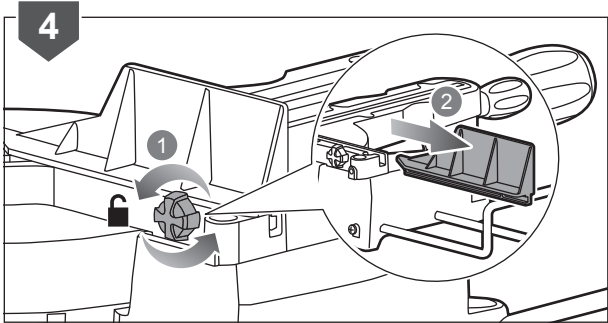

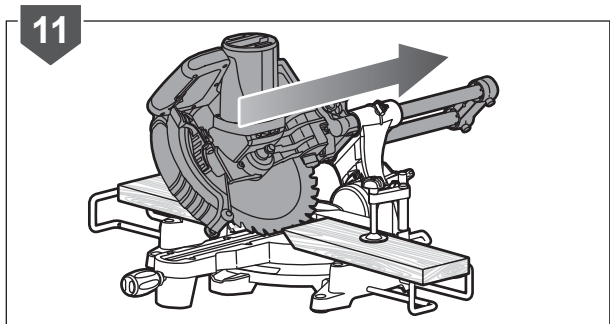
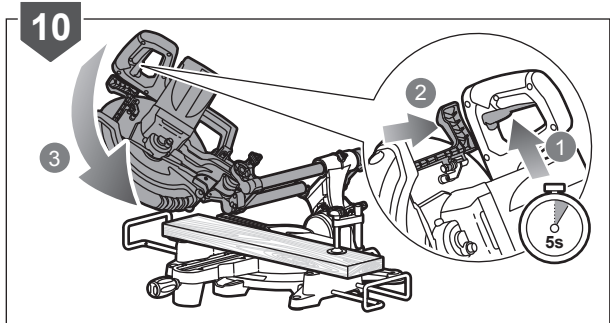
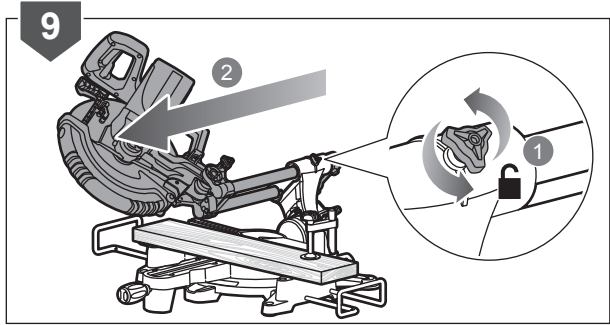
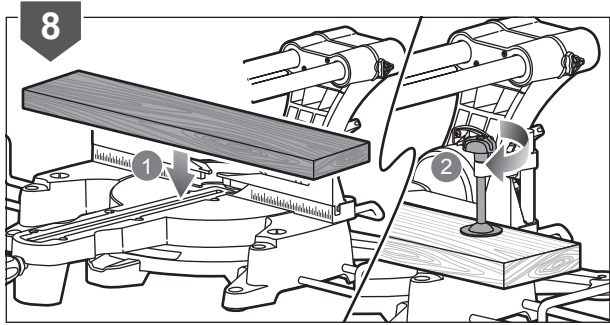

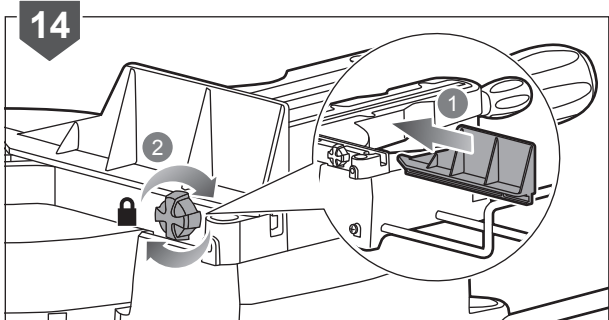
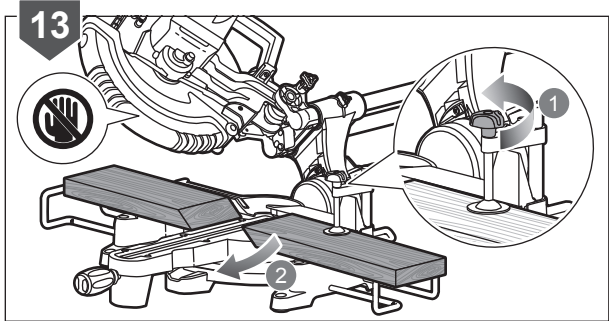
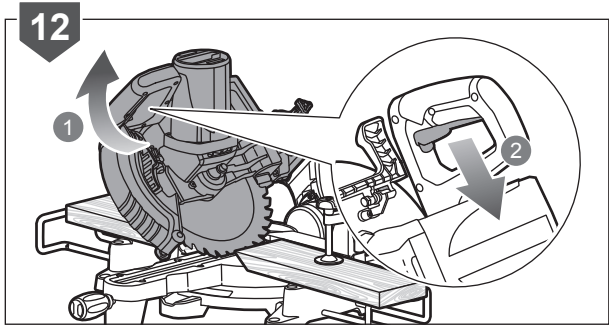

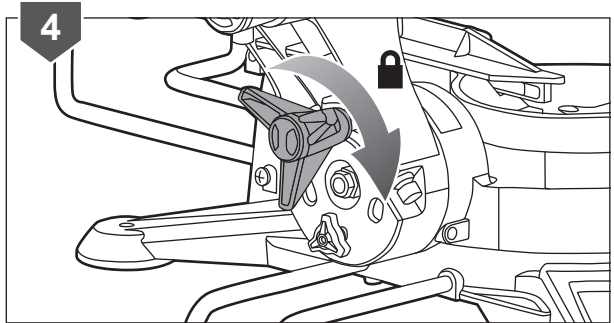
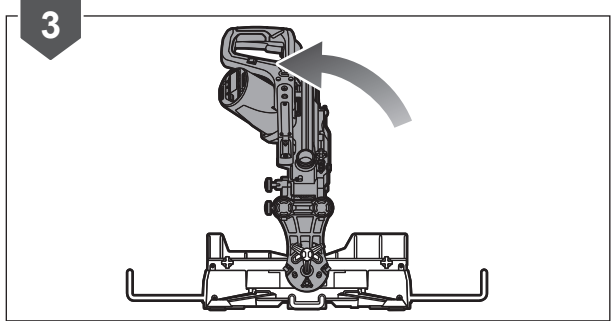
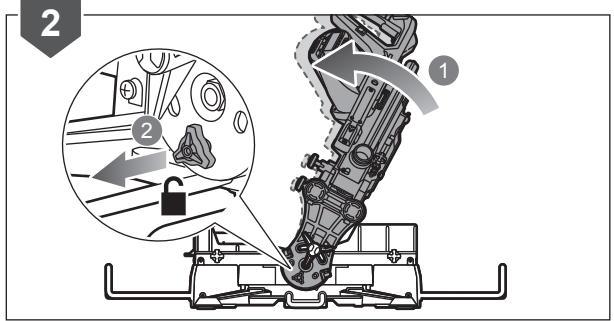
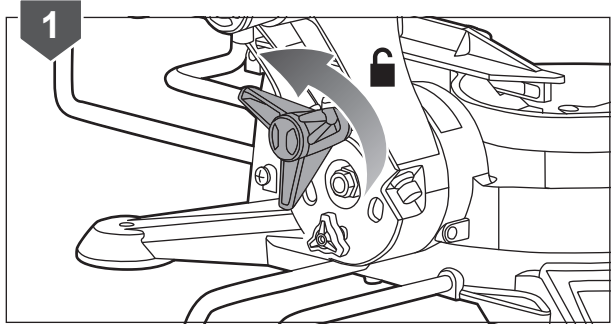
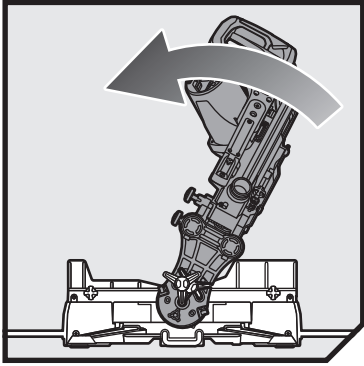

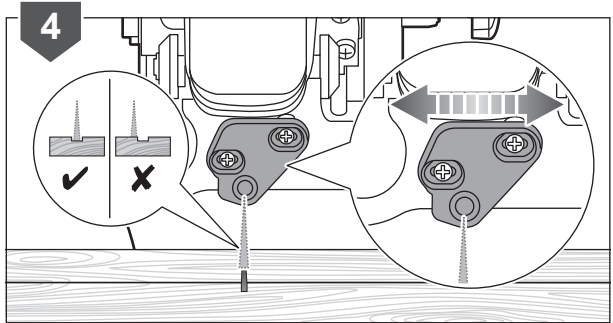
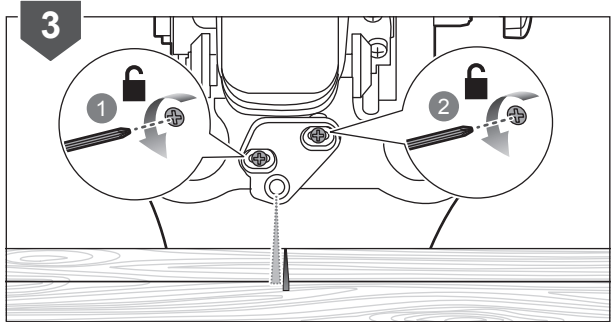
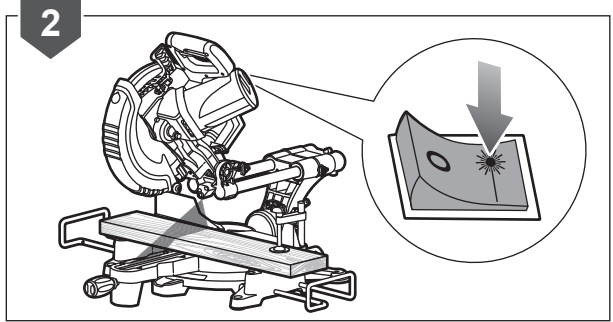
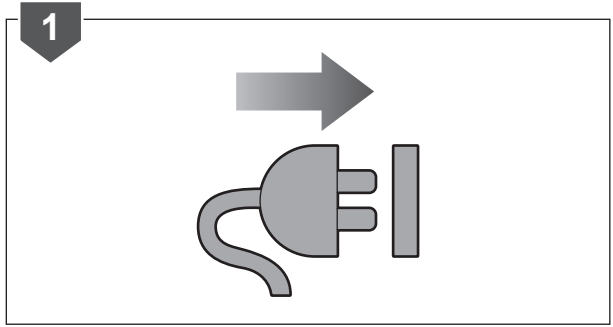
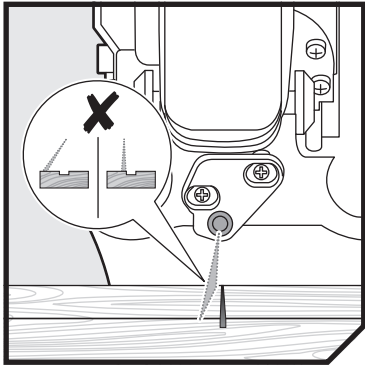

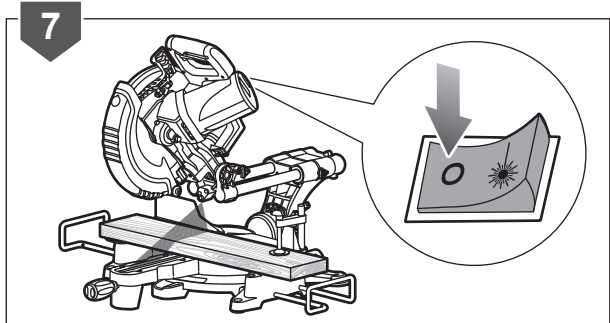
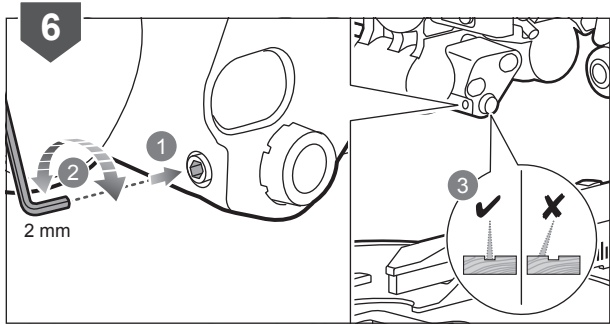
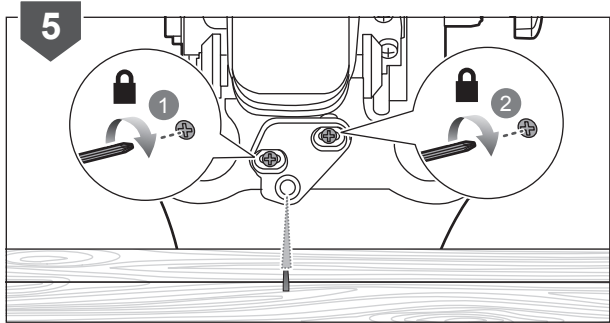

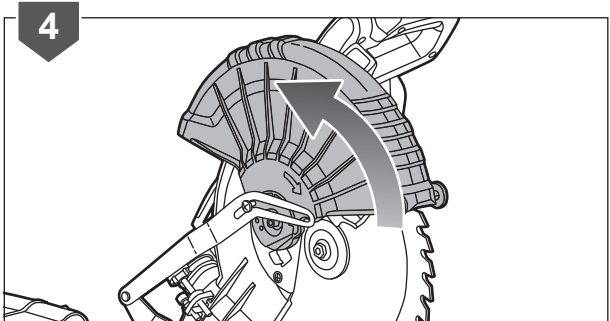
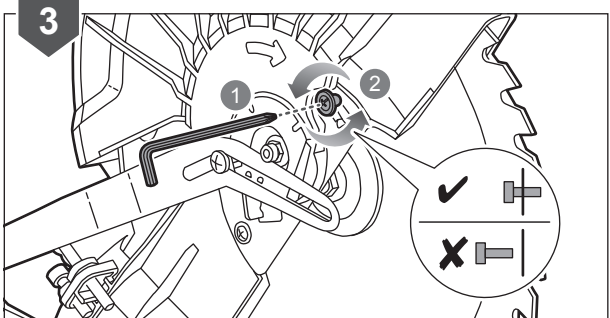
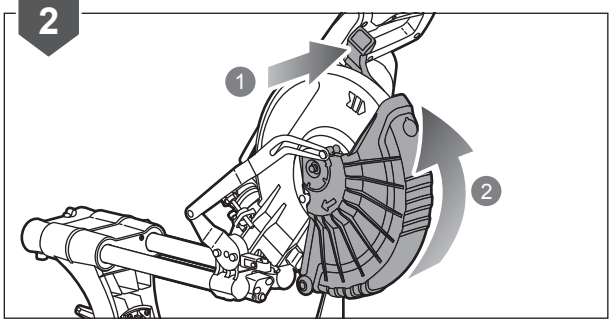
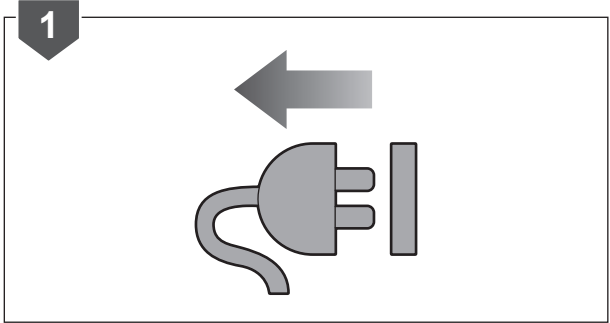
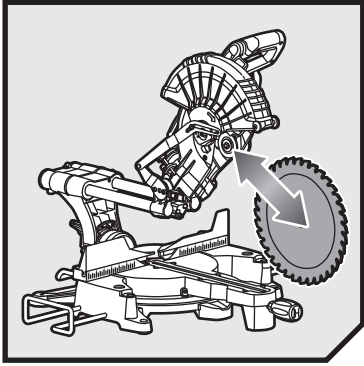

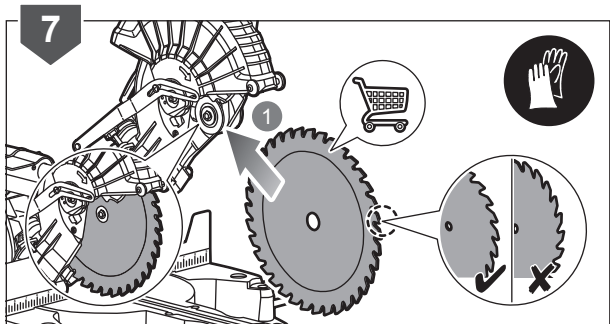
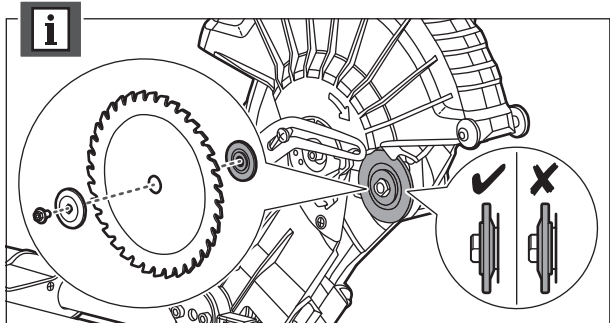
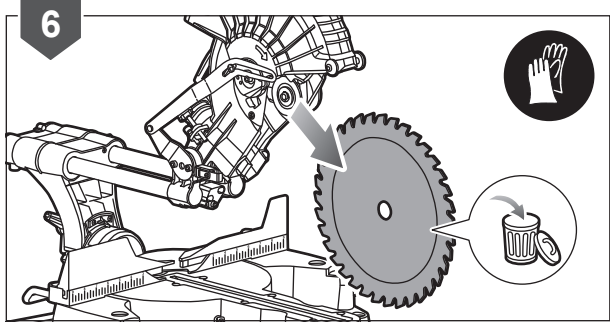
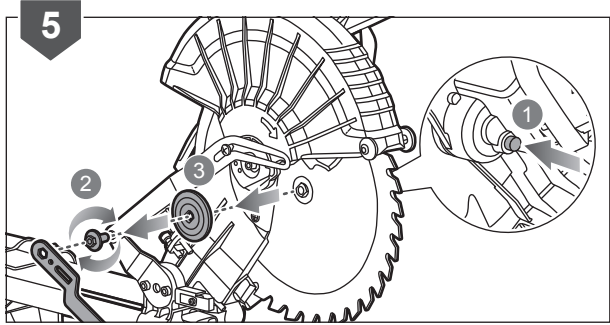

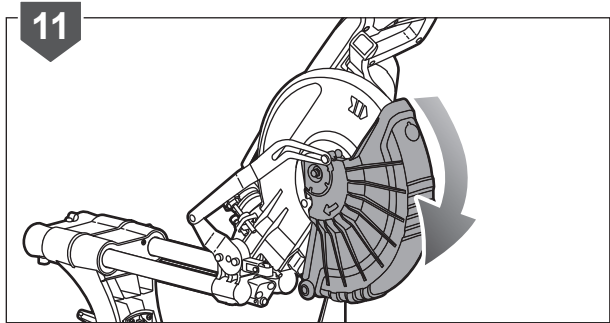
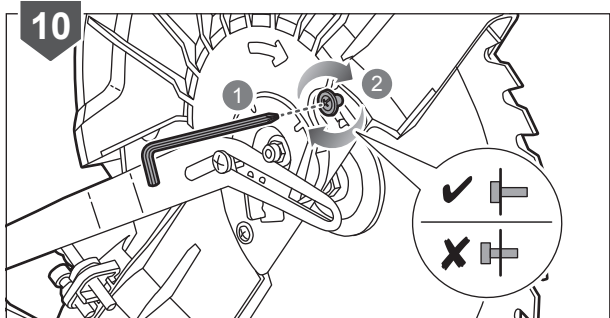
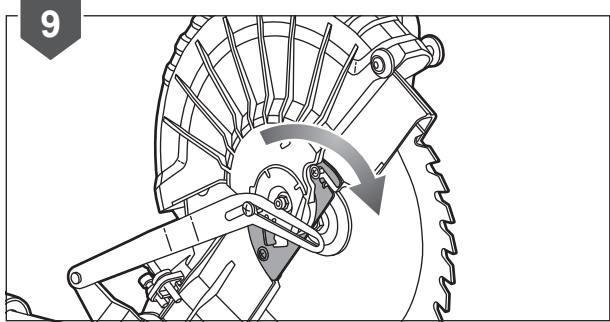
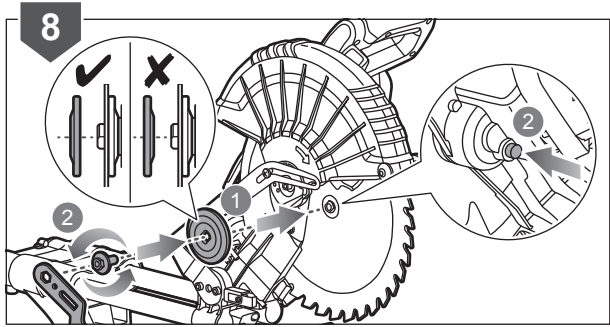

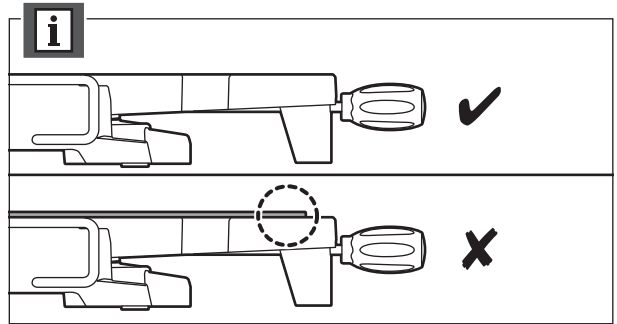
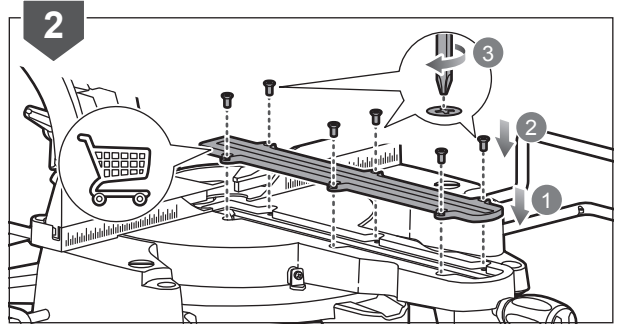
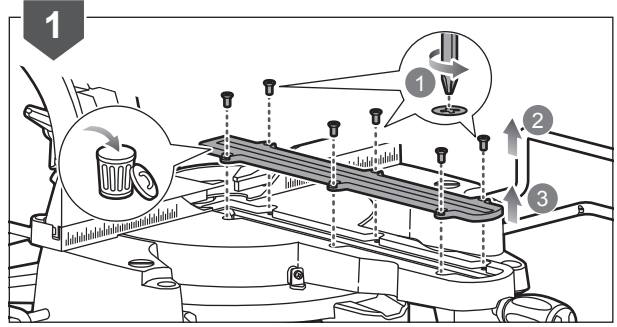
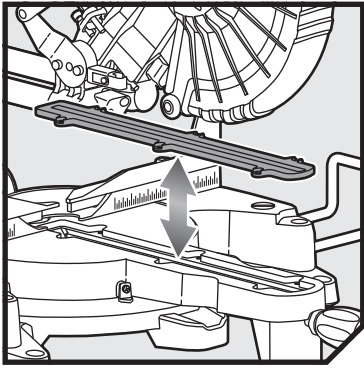

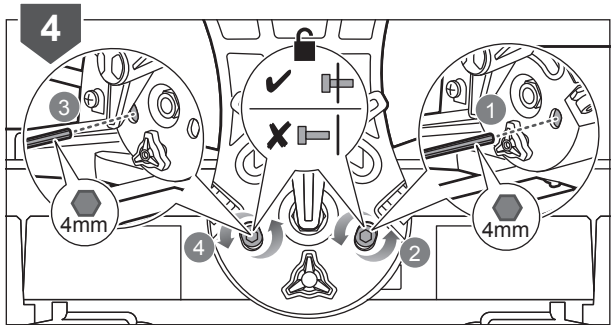
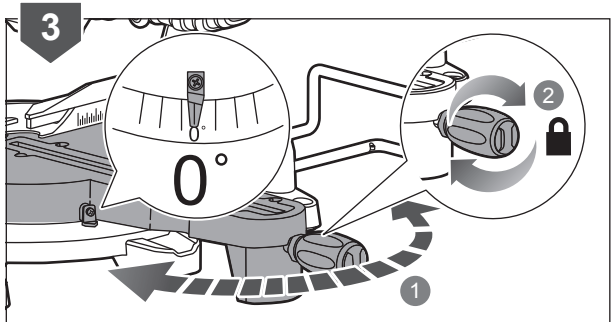
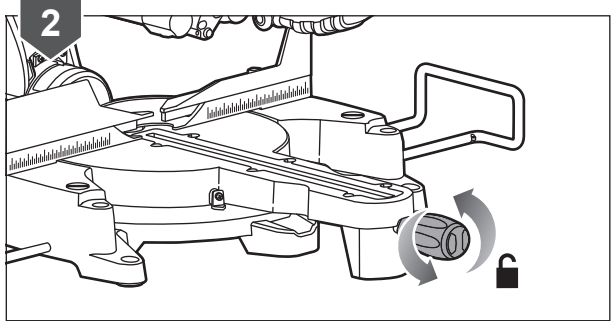
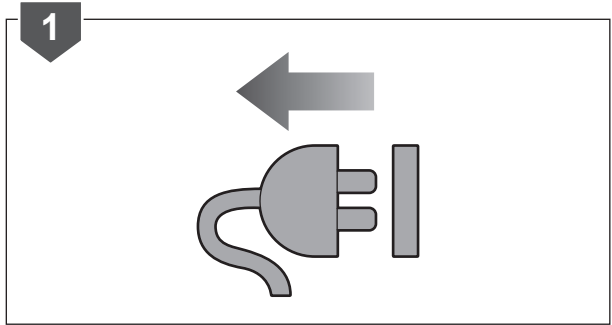
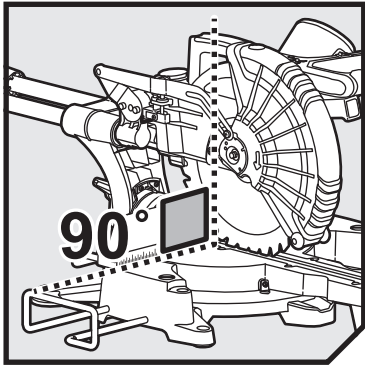

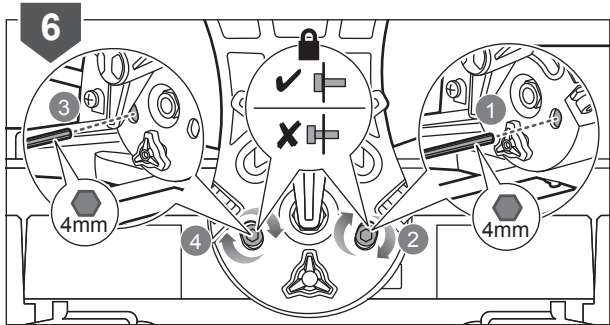
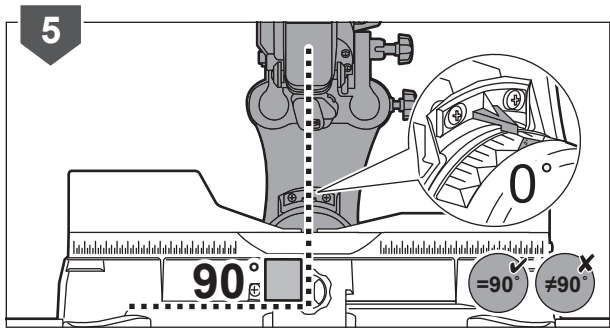

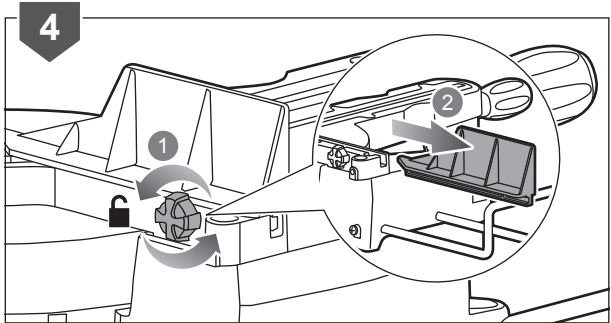
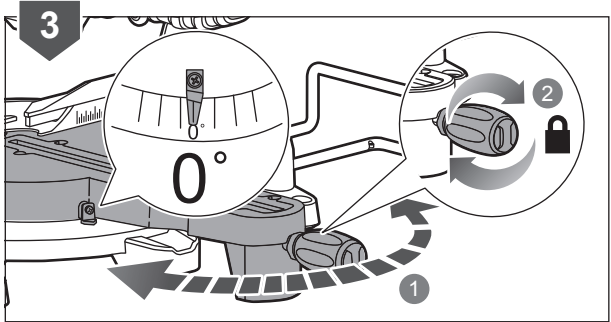
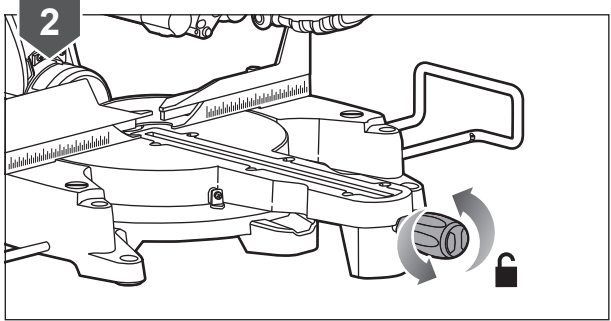
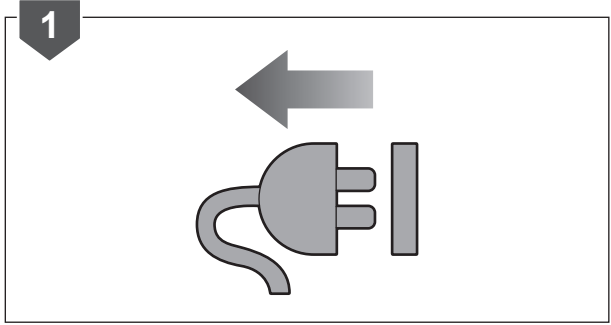
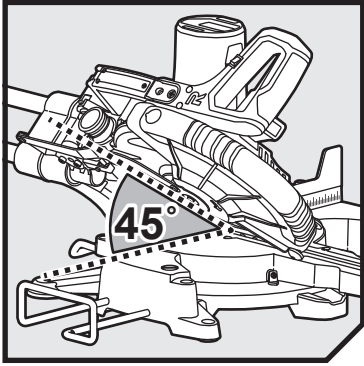

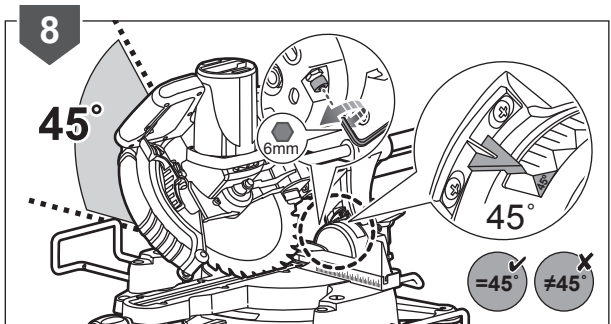
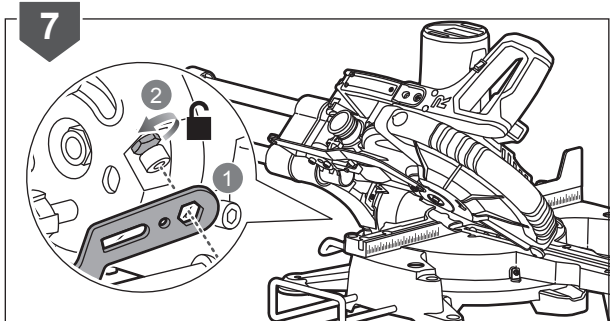
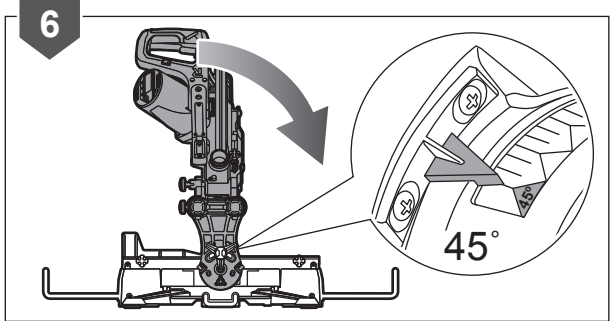
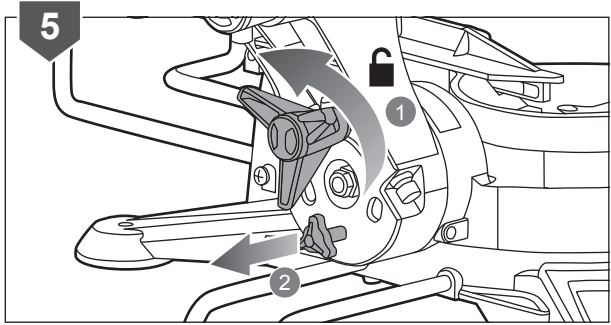

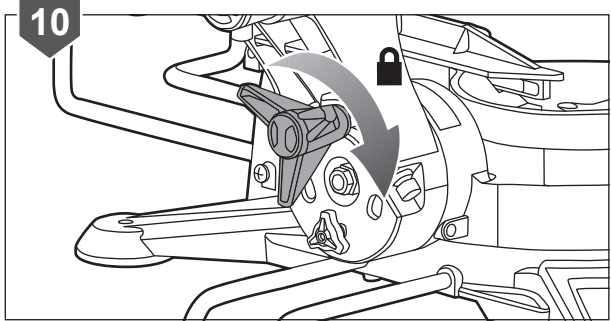
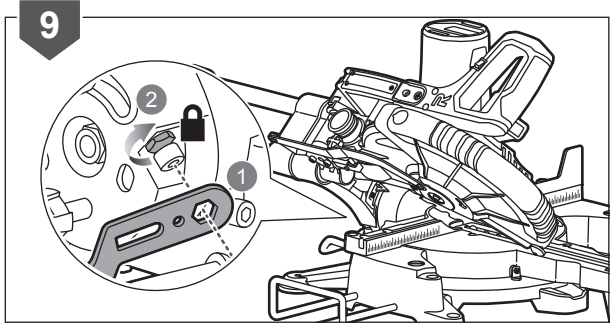

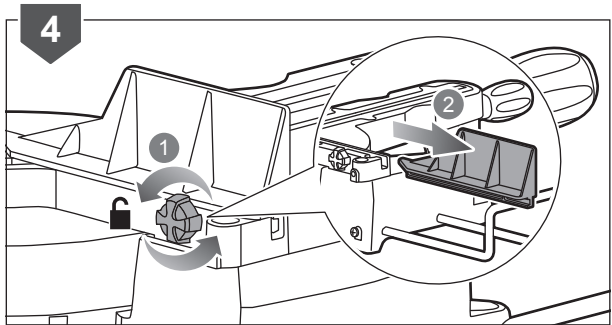
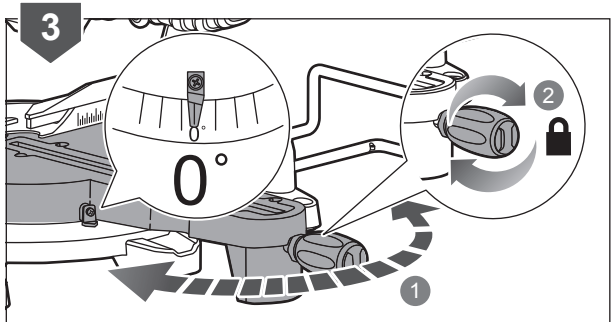
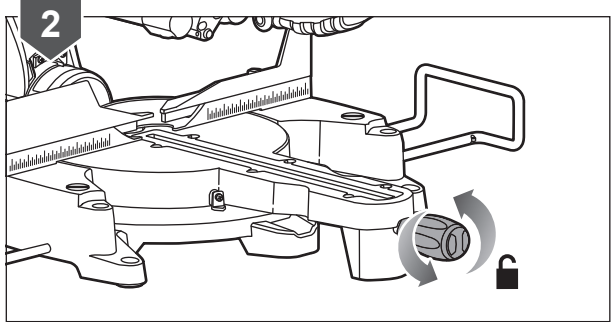
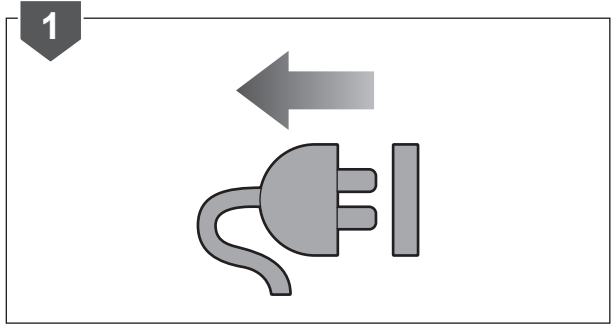
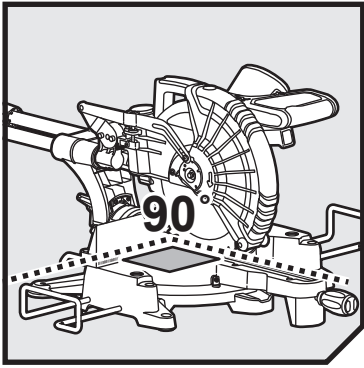

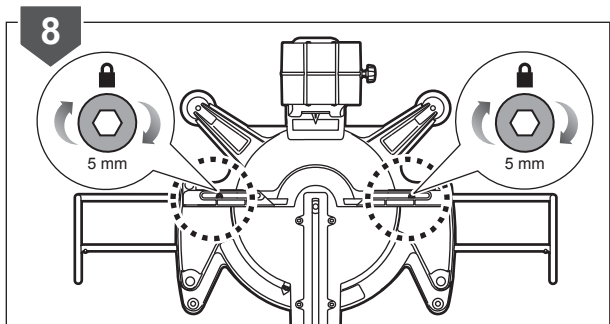
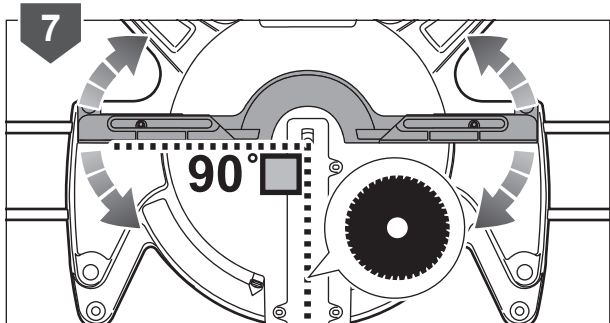
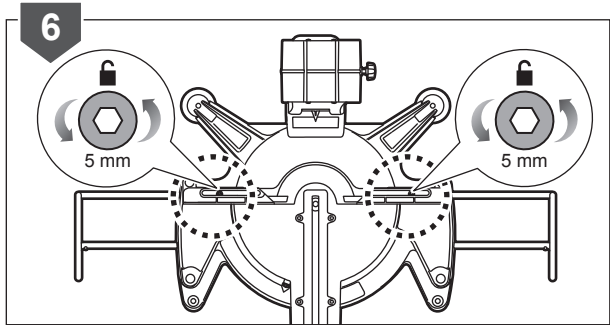
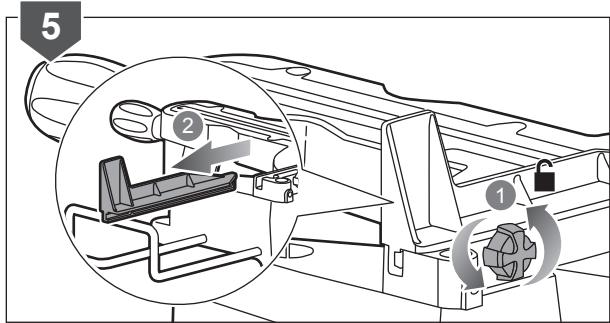

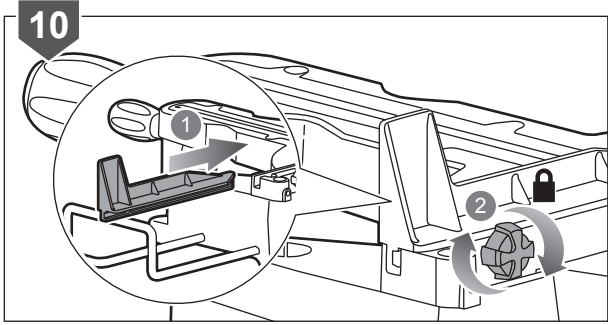
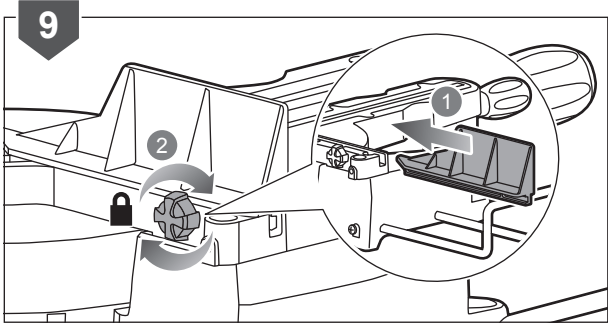

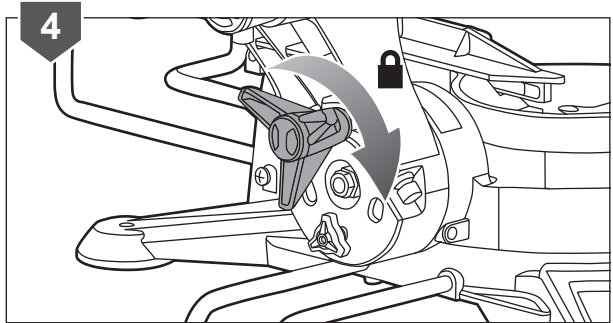
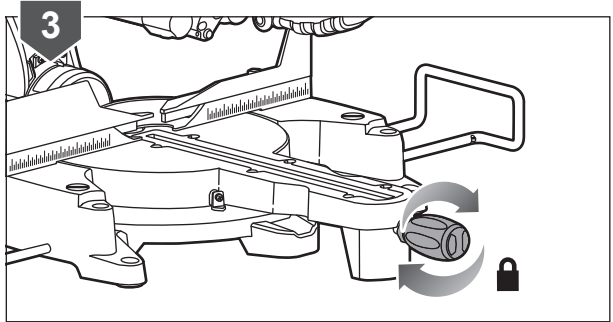
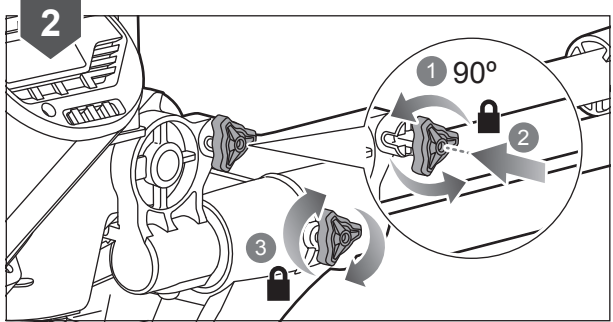
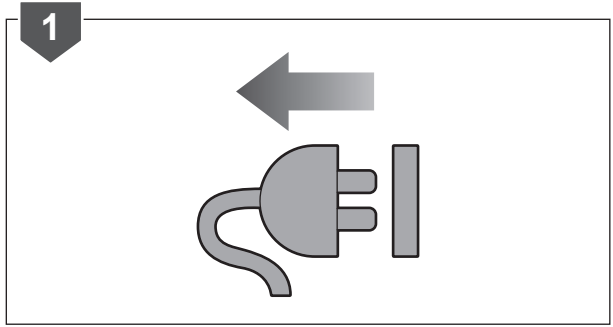
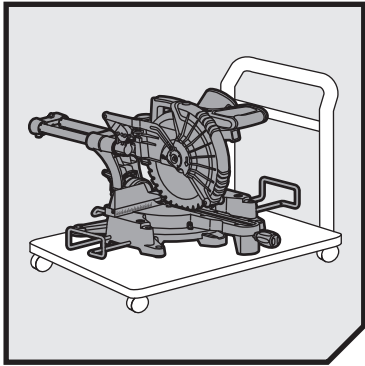

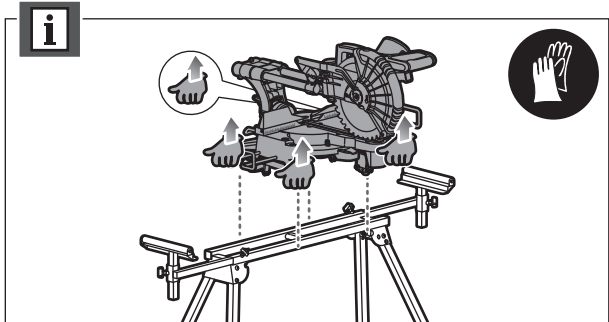
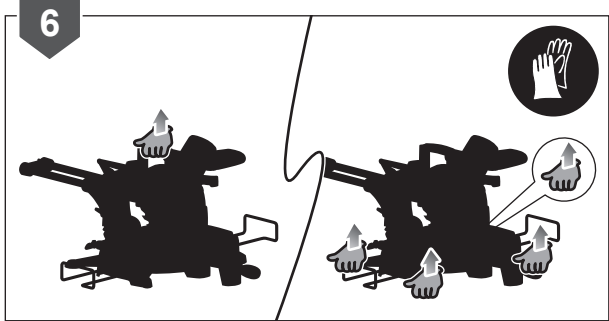
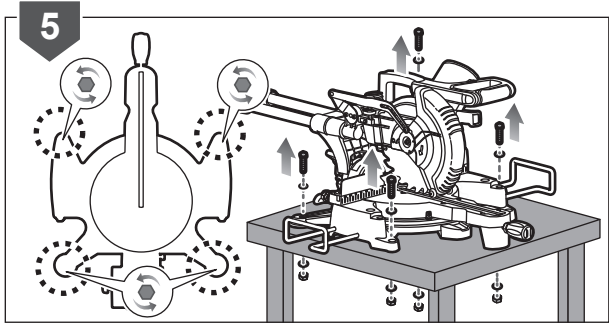

PRODUCT SPECIFICATIONS

Mitre saw	
Model	RMS305DB
Net weight	18.5 kg
Blade diameter	305 mm
Arbor hole	30 mm
Blade teeth	48
Width of cut	2.8 mm
No-load speed	5500 min ⁻¹
Input	220V - 240V ~ 50 Hz
Power	2000 W
Cutting capacity:	
Mitre 0° x bevel 0°	320 mm x 105 mm
Mitre 0° x bevel 45° (L)	320 mm x 60 mm
Mitre 0° x bevel 45° (R)	320 mm x 40 mm
Mitre 45° x bevel 0°	225 mm x 105 mm
Mitre 45° (L) x bevel 45° (L)	225 mm x 60 mm
Mitre 45° (R) x bevel 45° (R)	225 mm x 40 mm
Minimum workpiece dimensions	130 mm x 35 mm x 2.5 mm
Measured values determined according to EN 62841	
A-weighted sound pressure level	$L_{pA} = 99.6 \text{ dB(A)}$
Uncertainty K	3 dB
Measured values determined according to EN 62841	
A-weighted sound power level	$L_{WA} = 109.08 \text{ dB(A)}$
Uncertainty K	3 dB
Replacement parts	
Saw blade	089317001001
Table insert	089312001134

NOISE LEVEL



WARNING

The declared noise emission value(s) have been measured in accordance with a standard test method of EN 62841-1 and EN 62841-3-9, and may be used for comparing one tool with another.

The declared noise value(s) may also be used in a preliminary assessment of exposure.

The noise emissions during actual use of the power tool can differ from the declared values depending on the ways in which the tool is used especially what kind of workpiece is processed.

Identify safety measures to protect the operator based on an estimation of exposure in the actual conditions of use (taking account of all parts of the operating cycle such as the times when the tool is switched off and when it is running idle in addition to the trigger time).

Wear hearing protection. Exposure to noise can cause hearing loss.

TROUBLESHOOTING

PROBLEM	POSSIBLE CAUSE	SOLUTION
Mitre saw will not start.	No power to the saw.	Check that the power cord is connected to a live power source.
Wood burns at ends of cut.	Dirty blade. Worn blade. Workpiece is binding.	Clean blade. Replace worn blade. Check position of the workpiece on table. Material must be flat, flush against fence and supported at both ends.
Workpiece frays or chips out	Finished side is down. Dull or chipped blade. Blade unsuitable for material. Workpiece is not supported.	Keep finished side of workpiece up or facing operator. Check for damaged blade teeth. Replace damaged blade. Check blade's information for material that can be cut. Support the edges of the workpiece during cut.
Blade binds, slowing or stopping saw.	Workpiece is misaligned on the table or ends are not supported	Workpiece must be flat on the table, flush against the fence and supported at both ends.
Blade does not cut through workpiece.	Depth stop setting in use.	Push depth stop in to disengage.
Saw is not cutting straight.	Bevel lock knob / lock pin is loose.	Tighten bevel lock knob / lock pin.
45° bevel is not accurate	Bevel angle not calibrated.	Follow the instructions in this manual to calibrate 45° bevel.
Laser is not aligned with the blade outline.	Laser head is misaligned	Follow the instructions in this manual to adjust the laser alignment.







*RYOBI is a trademark of Ryobi Limited,
and is used under license.
© 2019 Techtronic Cordless GP. All rights reserved.*

Techtronic Industries Australia Pty Ltd
31 Gilby Road, Mount Waverley,
VIC, 3149, Australia

Techtronic Industries N.Z. Limited
Unit C, 70 Business Parade South,
Highbrook, Auckland 2013, New Zealand

20191014v1c