

AQUAPRO

CREATE A BIT OF BRILLIANCE IN YOUR OWN BACKYARD

AP1000F / AP2400F POND & FOUNTAIN PUMP - INSTRUCTIONS -



MODEL
02AF009
02AF010
DATE
MAY v2.0

HOTLINE 1300 278 283 PHONE +61 (8) 6260 1000
EMAIL SALES@AQUAPROONLINE.COM.AU

WWW.AQUAPROONLINE.COM.AU



AQUAPRO

CONGRATULATIONS ON YOUR PURCHASE OF THIS PRODUCT BY AQUAPRO.

TECHNICAL SPECIFICATIONS

DESCRIPTION	AP1000F	AP2000F
VOLTAGE*	220-240V	220-240V
POWER	36W	92W
MAX HEAD HEIGHT	2.00M	2.80M
MAX FLOW	1200L/H	2600L/H
IP RATING	IP68	IP68
FREQUENCY	50HZ	50HZ
INLET Ø BSP FEMALE THREAD	3/4 IN	1 IN
OUTLET Ø BSP FEMALE THREAD	1/2 IN	3/4 IN
CABLE LENGTH	10M	10M

* SUBJECT TO VARIATION ACCORDING TO LOAD.

Please read these instructions and familiarise yourself with the equipment before placing it in service. Correct and safe use of the system requires strict compliance with the safety instructions. For safety reasons persons less than 16 years of age or people that are not familiar with these instructions should not use this equipment.

FEATURES

THE AQUAPRO FOUNTAIN AND POND PUMP HAVE BEEN MANUFACTURED WITH ADVANCED TECHNOLOGY TO PROVIDE YOU WITH THE BEST QUALITY PUMP FOR YOUR POND OR WATER FEATURE.

- AQUAPRO Fountain & Pond pumps are suitable either submersible or inline.
- AQUAPRO Fountain & Pond pumps are a magnetically driven centrifugal pump, therefore they cannot suck from a water level that is below the inlet level when used inline.
- Your AQUAPRO Fountain & Pond pump has a single moving part (an impellor set) enabling easy cleaning and maintenance.
- The motor and electrical components are encapsulated in epoxy resin, ensuring safe operation under water.
- The pump has a robust bearing and shaft design so no oil/grease lubrication is required.
- AQUAPRO pumps that have plastic impellor parts and ceramic shafts, with no exposed metal, can be used in salt water applications.
- AQUAPRO fountain pumps are fitted with suction cup feet, enabling use on both horizontal and vertical surfaces.
- AQUAPRO Fountain & Pond Pumps are continuous rated therefore are designed to operate 24/7.

AP1000F / AP2400F PUMP INSTRUCTIONS

INSTALLATION

- Once a fountain nozzle has been selected, assemble the fountain kit as per the diagram on next page.
- Screw the T-piece onto the pump outlet and adjust the telescopic riser to the desired height and align vertically. On the Dual Control Flow Adjuster, on the T-piece, you can vary the flow between the fountain head and the waterfall outlet. Close the second outlet of the T-piece if this is not required for an optional waterfall or water spout.
- Place the pump in desired location, ensure the pump is on a stable surface that is free of sludge, sand and other debris, and connect tubing to the outlet or attach fountain kit.
- Position the device in the pond horizontally, on a solid base, in such a way that it is fully covered with water and the fountain nozzle protruding out of the water.
- Push the plug into the power supply outlet and switch on.

CLEANING INSTRUCTIONS

BEGIN BY ENSURING THAT THE MAINS POWER SUPPLY IS DISCONNECTED BEFORE ATTEMPTING ANY MAINTENANCE OR ADJUSTMENT OF THE UNIT.

- Remove the unit from the water. The filters and sponges in this unit will clog over time. Please clean regularly (at least once a month) to ensure strong water flow. Failure to maintain the unit will result in a burnt out motor and other damage.
- All AQUAPRO Pond & Fountain pumps are water cooled, if pump becomes restricted, or blocked, it will overheat and could cause permanent damage. The motor unit of the pump is encapsulated with epoxy resin and does not need lubrication. Regular inspections, cleaning and maintenance of impellor is necessary to ensure longer impellor life.
- Take off the fountain set first. Unscrew the fountain kit from the top of the unit. Examine the nozzles to ensure all ports are unblocked. Clean with a suitable brush if necessary.
- Maintain the filter sponge regularly according to how quickly the sponge gets clogged up. When the flow starts to be reduced, check and clean if necessary.
- Unclip the front filter cage from the front of the pump and take out the filter sponge and clean. If using an optional prefilter block sponge, slide the sponge off the threaded core and wash out. It is recommended that this is done in a bucket of pond water to ensure the good bacteria that are present in the sponge are not killed by the Chlorine in tap water. Check for wear and tear of the sponges. Replace if necessary.
- To maintain the impellor of the pump, turn the Impellor cover locking ring in an anti-clockwise direction to the stop position and lift off. Then you can separate the impellor cover from the pump body. Take out the impellor. (Take care not to break ceramic shaft because it is brittle.)
- Clean the impellor with clean water and a suitable brush. Inspect for signs for wear and tear. If the impellor set becomes worn or damaged it should be replaced (available from your dealer or special orders). Failure to do so may cause serious damage to pump. The impellor set is a wearing consumable part.
- Once the cleaning and inspection process is completed, reassemble in the reverse manner. Reinstall the shaft into the motor body, and then carefully slide the impellor onto the shaft. The impellor will pull itself in by magnetic force, this is normal (take care not to pinch your fingers or break the shaft).
- Replace the impellor cover, making sure the shaft is located properly on the impellor cover. You may need to place rubber impellor locator (Grommet) on end of shaft to locate into impellor cover properly. Reattach the locking ring.
- Replace the internal sponge and front cage or foam block sponge prefilter.
- Re-attach fountain kit and/or tubing, relocate in water, connect to power supply and turn on.

AQUAPRO

PART DESCRIPTION

1. FRONT FILTER CAGE
2. BIOSPONGE
3. IMPELLOR COVER LOCKING RING
4. INLET HOSE TAIL - 1IN BSP TO 25MM
5. INTAKE SCREEN
6. IMPELLOR COVER
7. IMPELLOR
8. MOTOR BODY
9. THREADED NIPPLE - 1/2IN TO 1/2IN
10. 20MM - 1/2IN BSP HOSE TAIL
11. OUTLET HOSE TAIL - 1/2IN BSP TO 20MM
12. T-PIECE & FOUNTAIN RISER
13. FOUNTAIN NOZZLE MOUNT
14. FOUNTAIN HEADS

NOTE: PARTS MAY DIFFER SLIGHTLY FROM SHOWN

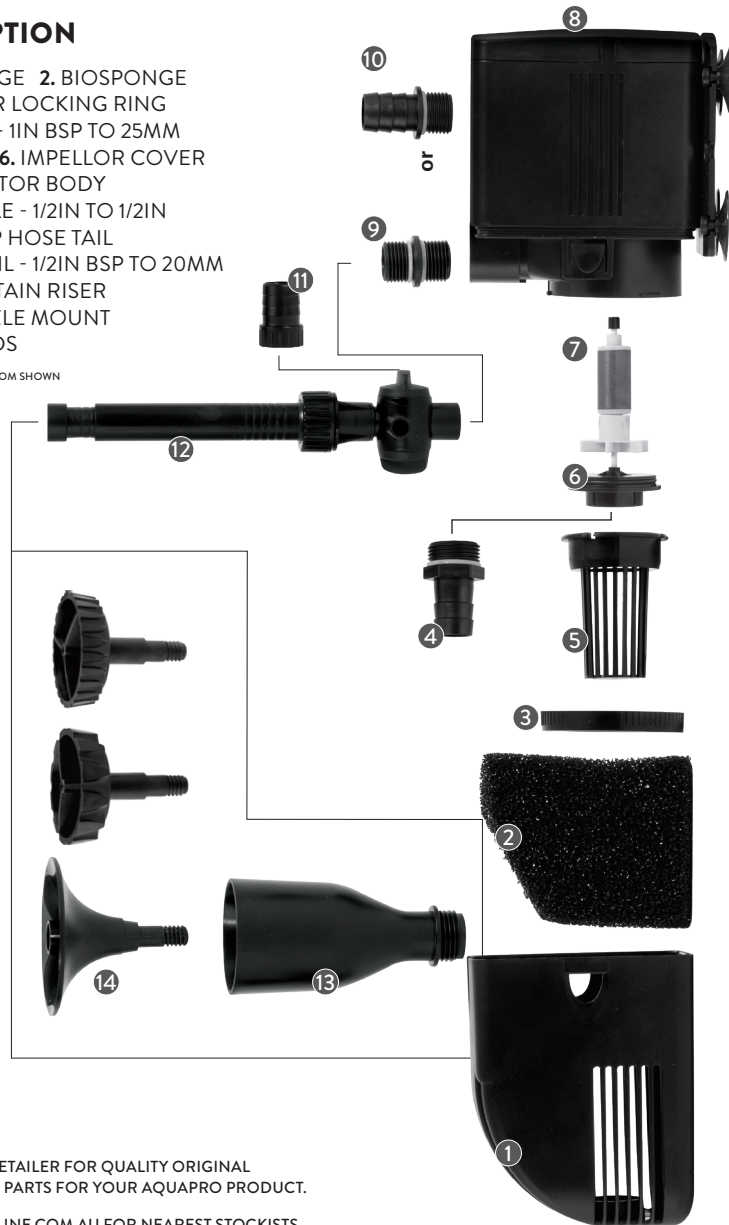

NOTE:
PLEASE CONSULT YOUR RETAILER FOR QUALITY ORIGINAL
AQUAPRO REPLACEMENT PARTS FOR YOUR AQUAPRO PRODUCT.

VISIT WWW.AQUAPROONLINE.COM.AU FOR NEAREST STOCKISTS.

AP1000F / AP2400F PUMP INSTRUCTIONS

SAFEGUARDS

DISCONNECT POWER CORD FROM THE POWER SUPPLY BEFORE PERFORMING MAINTENANCE. NEVER LIFT THE PUMP BY THE POWER CORD.

- Be sure the equipment is submerged completely in the water. The depth should not be greater than 2m.
- Do not operate the pump if the appliance or any components of the system, such as the power cable, have been damaged.
- The pump is designed to be used in a Garden pond or Aquarium environment. It is not to be used in any other manner or purpose.
- The pump should only be used in clean water. Do not use the pump in, or with, any chemicals such as a solvent or gasoline.
- All AQUAPRO Fountain & Pond pumps are water cooled. If the pump flow becomes restricted it will overheat and could cause permanent damage. The pump needs to be cleaned regularly to prevent the pump becoming blocked, thus causing the pump to overheat and burn out. This is not a warrantable event.
- For your own safety, disconnect from the power supply before any maintenance of any equipment is attempted on the tank or water body.
- Be sure the equipment is submerged completely in the water. The depth should not be greater than 2m.
- Do not operate the pump if the appliance or any components of the system, such as the power cable, have been damaged.
- Always use a properly grounded power supply that is connected to an RCD with a rated residual operating current not exceeding 30mA. As per AS/NZS 3350.2.41:1997
- The drip loop method should be used to prevent water from traveling down the cable and onto the plug or power supply. If the plug does get wet, do not unplug the cable. Disconnect the circuit breaker that supplies power to the power supply point. Then unplug and examine the plug and power supply point for presence of water. If the power point has become wet, you should consult an electrician before using the power point again.
- Always unplug the pump from the power supply when not in use or before performing any maintenance on the pump or in the pond. Never pull the cable to disconnect the plug from the power supply. Grasp the plug and pull to disconnect.
- Use of extension cords outdoors is not recommended.
- If required, have a qualified electrician install a weatherproof power supply point near to the pond or water-feature (within the cable length of the appliance).
- Do not install or store the appliance where it will be exposed to extreme hot or cold temperatures. Do not use in water above 35°C.
- Do not cut the cable as this will result in voiding your warranty.
- Care should be taken to arrange the power cable so that it cannot be accidentally tripped over or pulled.
- Do not attempt to repair the electrical appliance yourself. Return to an authorized service centre or place of purchase if a fault occurs, (regular maintenance is not considered repair and is required by user).
- The power cord cannot be replaced. If the cord is damaged, the pump must be discarded.

TROUBLESHOOTING

PROBLEM	REASON	SOLUTION
WATER PUMP NOT WORKING	NO POWER	CHECK THAT THE PLUG IS CONNECTED AND TURNED ON
	SPONGES AND FILTER MEDIA BLOCKED WITH SLUDGE	CLEAN THE SPONGES AND FILTERS
	IMPELLOR IS BLOCKED WITH SLUDGE OR LIMESCALE	CLEAN THE IMPELLOR AS PER THE INSTRUCTIONS
	RUNNING WITHOUT SUFFICIENT WATER	SUBMERSE THE EQUIPMENT UNDERWATER THEN PLUG IN. REFILL IF NECESSARY.
WATER PUMP IS NOISY	BLOCKAGE IN PUMP	CLEAR THE BLOCKAGE
	IMPELLOR & SHAFT WORN OUT	REPLACE IMPELLOR & SHAFT
	IMPELLOR BROKEN	REPLACE IMPELLOR
	WATER VALVE CLOSED ON THE OUTLET	OPEN THE VALVE AND ALLOW WATER TO FLOW
	UNIT INLET IS BLOCKED OR THE WATER PUMP INLET IS BLOCKED	CLEAR ALL BLOCKAGES

SPARE PARTS (NOTE: THESE ARE THE MOST USED)

KIT NAME	DESCRIPTION
AQUAPRO AP1000F v.2019 IMPELLOR COVER KIT	11A1246
AQUAPRO AP2400F v.2019 IMPELLOR COVER KIT	11AR961

IMPORTANT SAFEGUARDS

IMPORTANT: IF USED IN MARINE OR SALTWATER, DUE TO THE HARSH CONDITIONS THE WARRANTY IS VOID.

To guard against injury, basic safety precautions should be observed including, but not limited to the following:

- The pump should only be used in clean water. Do not use the pump in any solvent or gasoline that is flammable.
- Do not operate the pump without water at any time, permanent damage may occur.
- Do not operate the pump if the pump or any of the components of the pump, such as the power cable, have been damaged.
- The drip loop method should be used to prevent water from traveling down the cord onto the plug or power point. If the plug does get wet, do not unplug the cord. Disconnect the circuit breaker that supplies power to the power point. Then unplug and examine the plug and power point for presence of water. If the power point has become wet, you should consult an electrician before using the power point again.
- Always use a properly grounded power supply that is connected to an RCD with a rated residual operating current not exceeding 30mA. As per AS/NZS 3350.2.41:1997.
- Always unplug the pump from the power supply when not in use or before performing any maintenance on the pump. Never pull the cord to disconnect the plug from the power supply. Grasp the plug and pull to disconnect.
- Do not install or store the pump where it will be exposed to extreme hot or cold temperatures.
- Do not cut the cord as this will result in voiding your warranty.
- Care should be taken to arrange the power cord so that it cannot be accidentally tripped over or pulled.
- Do not attempt to repair the pump yourself. Return to an authorised service centre or place of purchase if a fault occurs.
- Do not use in water above 35°C.

WARRANTY

WARRANTY COVERS ONLY APPLIANCE DEFECTS, FAULTY MATERIAL AND WORKMANSHIP WITHIN A 2 YEAR PERIOD.

- Faults arising due to; accidents, misuse, not following manufacturer's guidelines/ instructions, or power surges/spikes/ brownouts will not be covered.
- The impellor set is a consumable item and is therefore not covered under warranty.
- Warranty will be void if any tampering, removal of warranty labels, or electrical circuitry is evident.
- Warranty will be void if the power cord is cut or damaged in any way.
- Warranty will be void if any visible signs of overheating are present.
- Loss of livestock, damage to property or personal injury caused by this product will not be covered.
- Warranty claims caused by installation faults will not be covered.
- It is the customer's responsibility to return the faulty appliance for any warranty claim to Aquatec.
- For any warranty to be valid, an original proof of purchase must be provided.
- Our goods come with guarantees that cannot be excluded under the Australian Consumer Law. You are entitled to a replacement or refund for a major failure and for compensation for any other reasonably foreseeable loss or damage. You are also entitled to have the goods repaired or replaced if the goods fail to be of acceptable quality and the failure does not amount to a major failure.

FOR MORE INFORMATION AND THE COMPLETE AQUAPRO RANGE
VISIT WWW.AQUAPROONLINE.COM.AU

HOTLINE 1300 278 283 PHONE +61 (8) 6260 1000

EMAIL SALES@AQUAPROONLINE.COM.AU

WWW.AQUAPROONLINE.COM.AU