

3 DRAWER FILING CABINET ASSEMBLY GUIDE

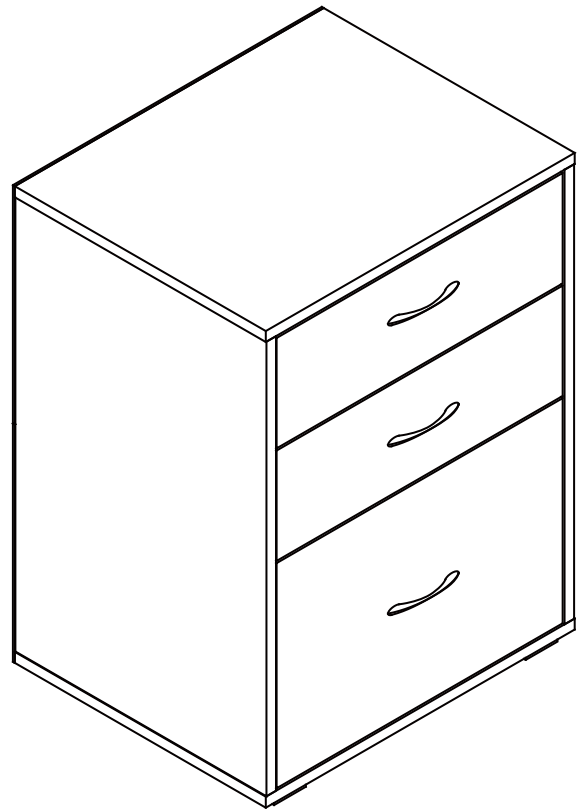

IMPORTANT















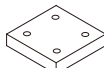
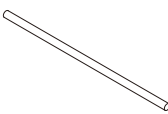

Before commencing assembly:

- Read all instructions COMPLETELY.
- Hardware kit contains small parts; keep out of reach of children.
- Ensure all listed parts are present.
- Required tools to assemble:

Phillips head screw driver, Drill

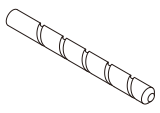
- Required assembly work surface should be solid, level, clean and flat.
- Ensure all edged surfaces are facing to the front of the unit.

Hardware List

A  8 pcs	B  17 pcs	C  16 pcs	D  16 pcs	E  30 pcs
F  3 pcs	G  22 pcs	H  4 pcs	I  2 pcs	J  14 pcs
K  1 pc	L  1 pc	M  2 pcs	N  1 pc	O  Drill Bit 1 pc
CL  3 pcs	CR  3 pcs	DL  3 pcs	DR  3 pcs	

Panel Layout

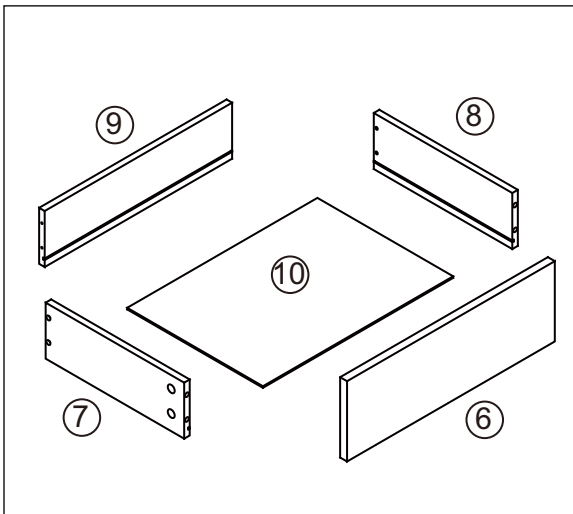
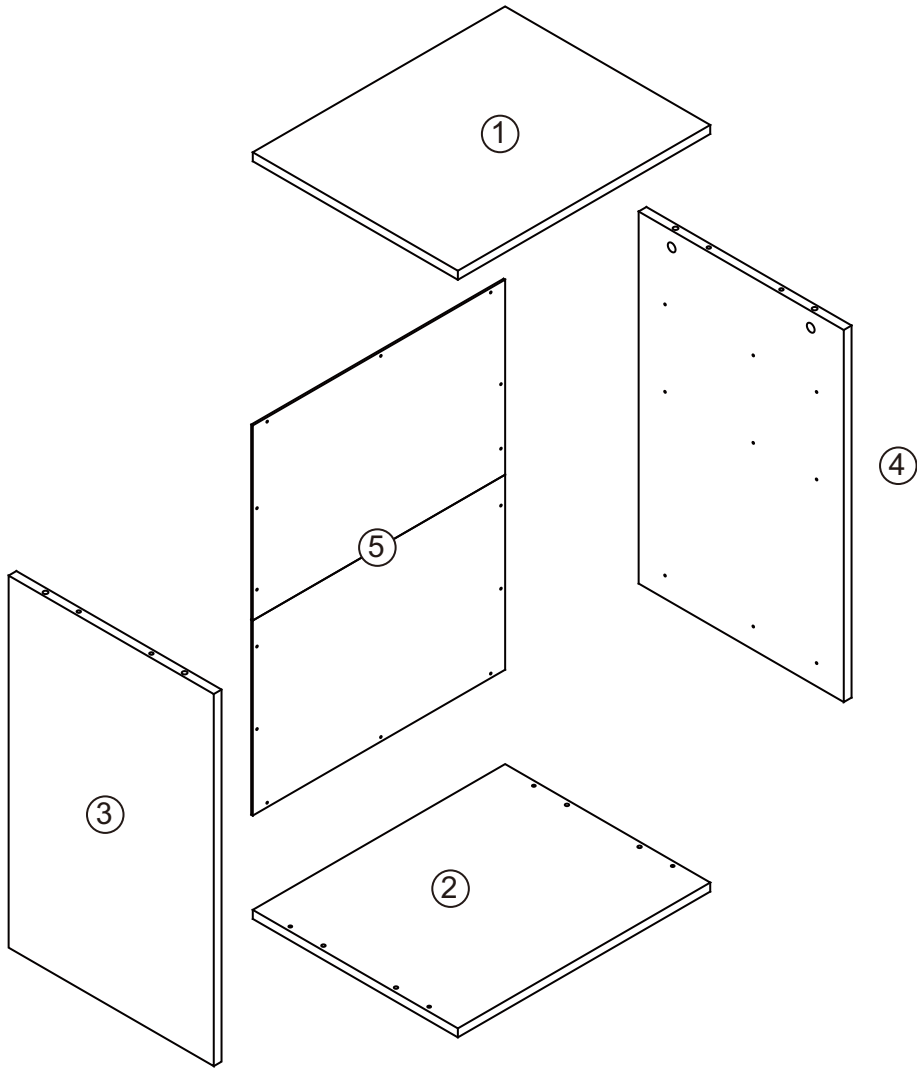

x2

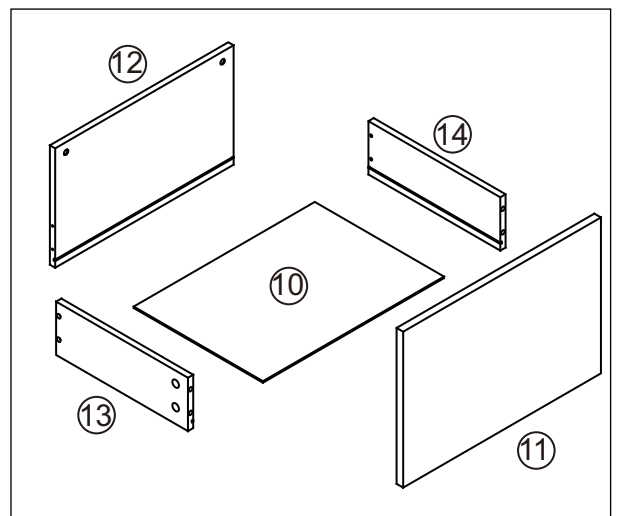

Step 1

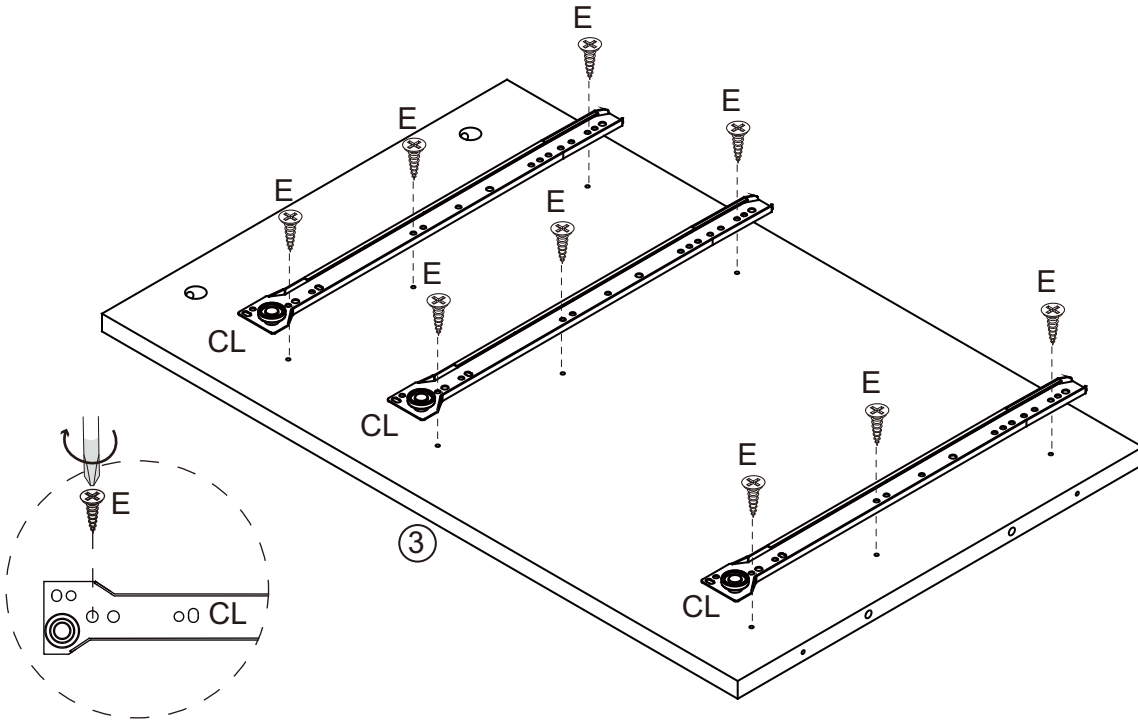

Step 2

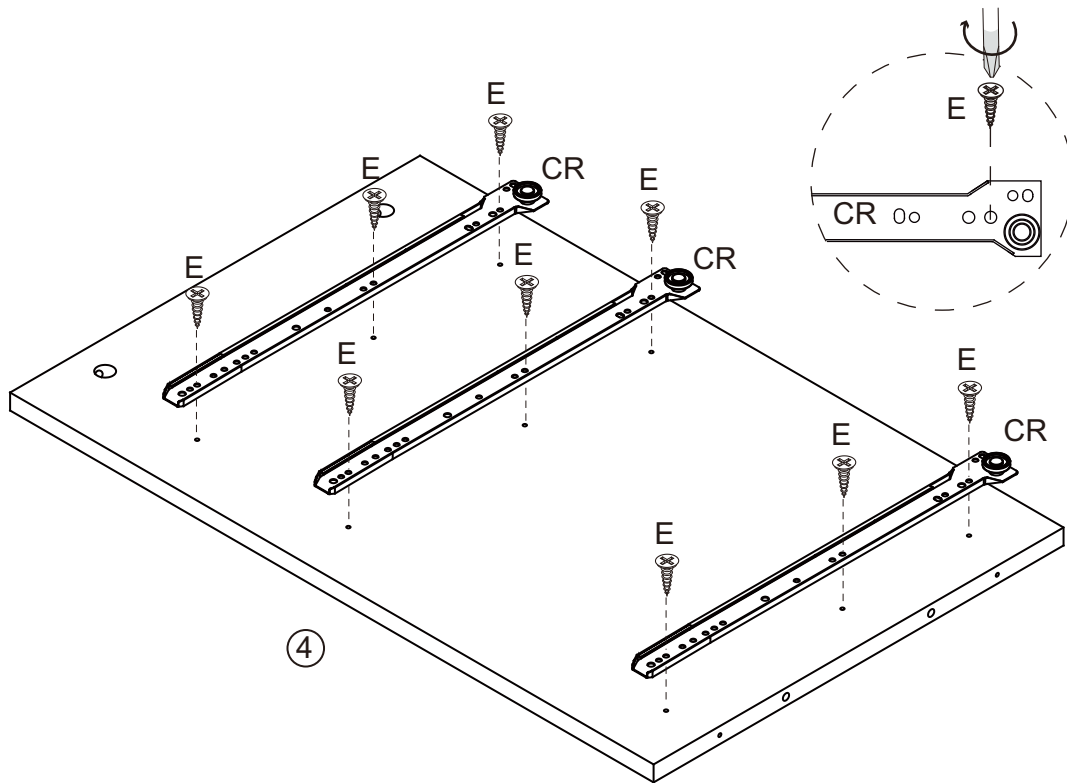

Step 3

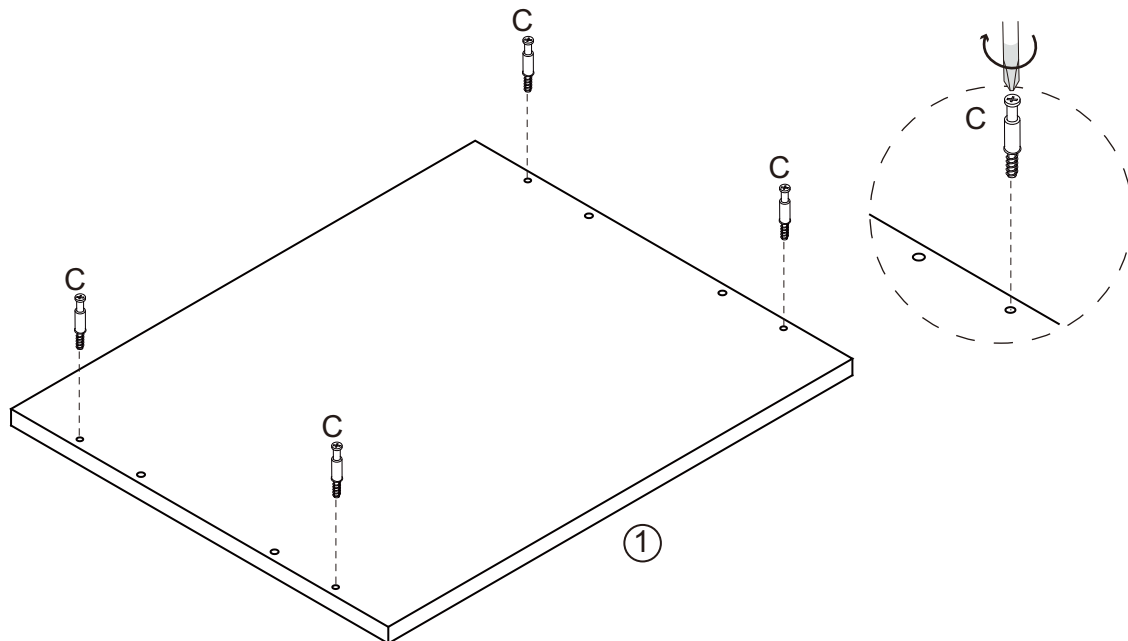

Step 4

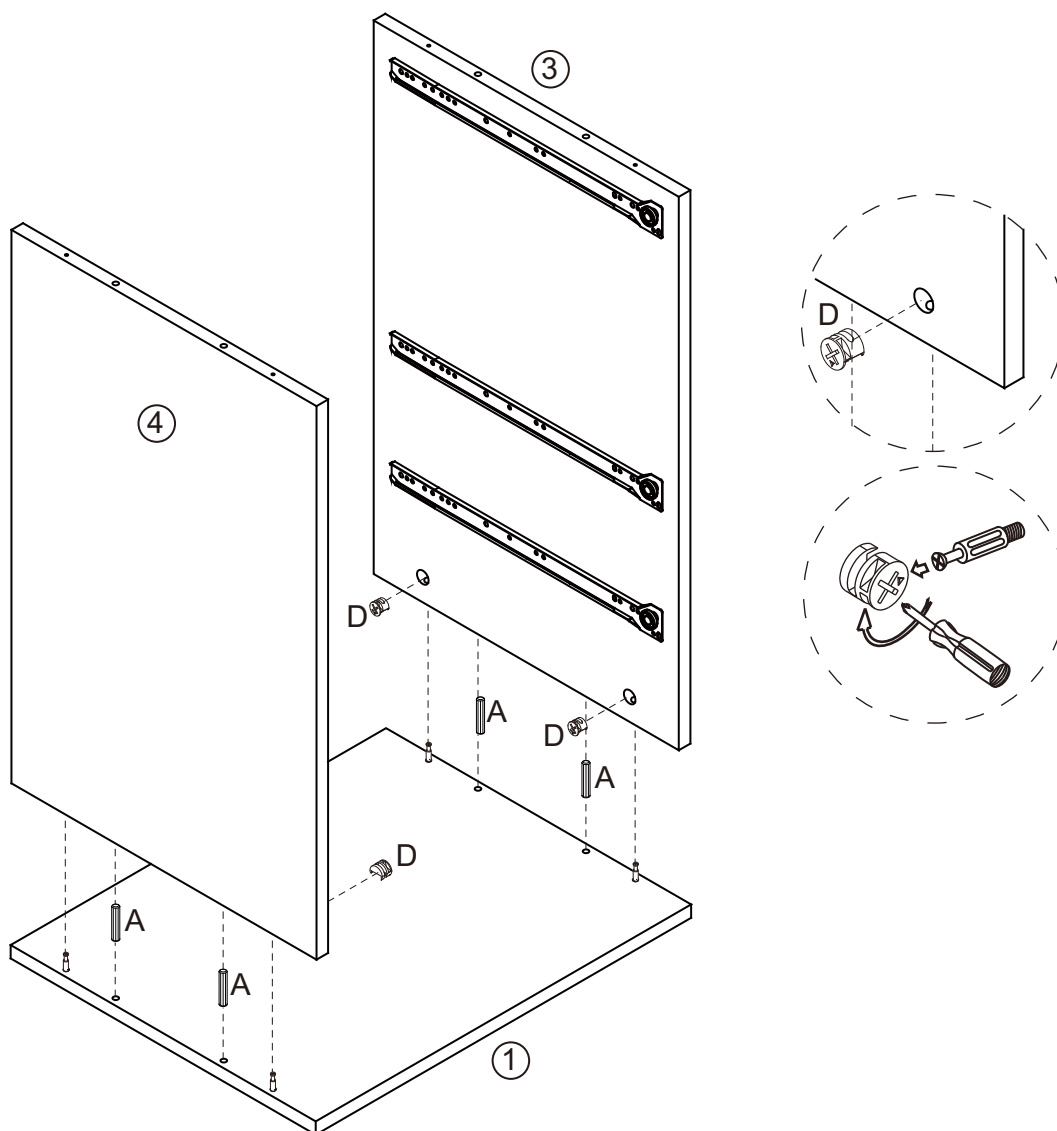

Step 5

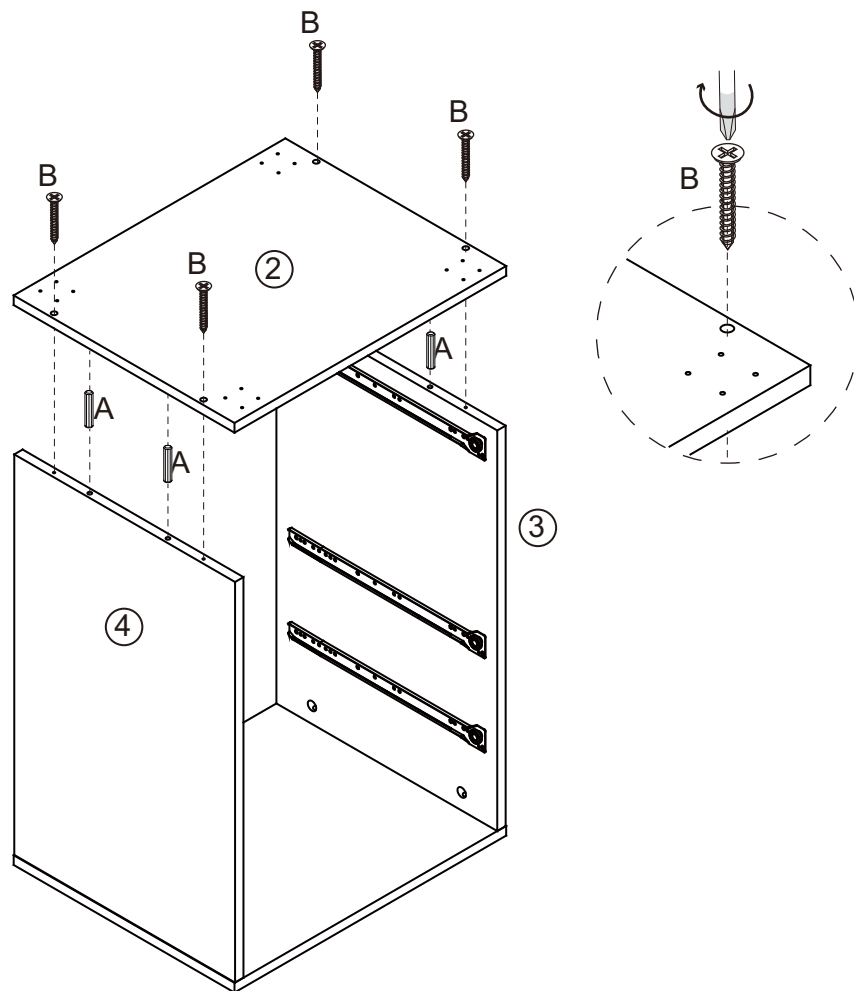

Step 6

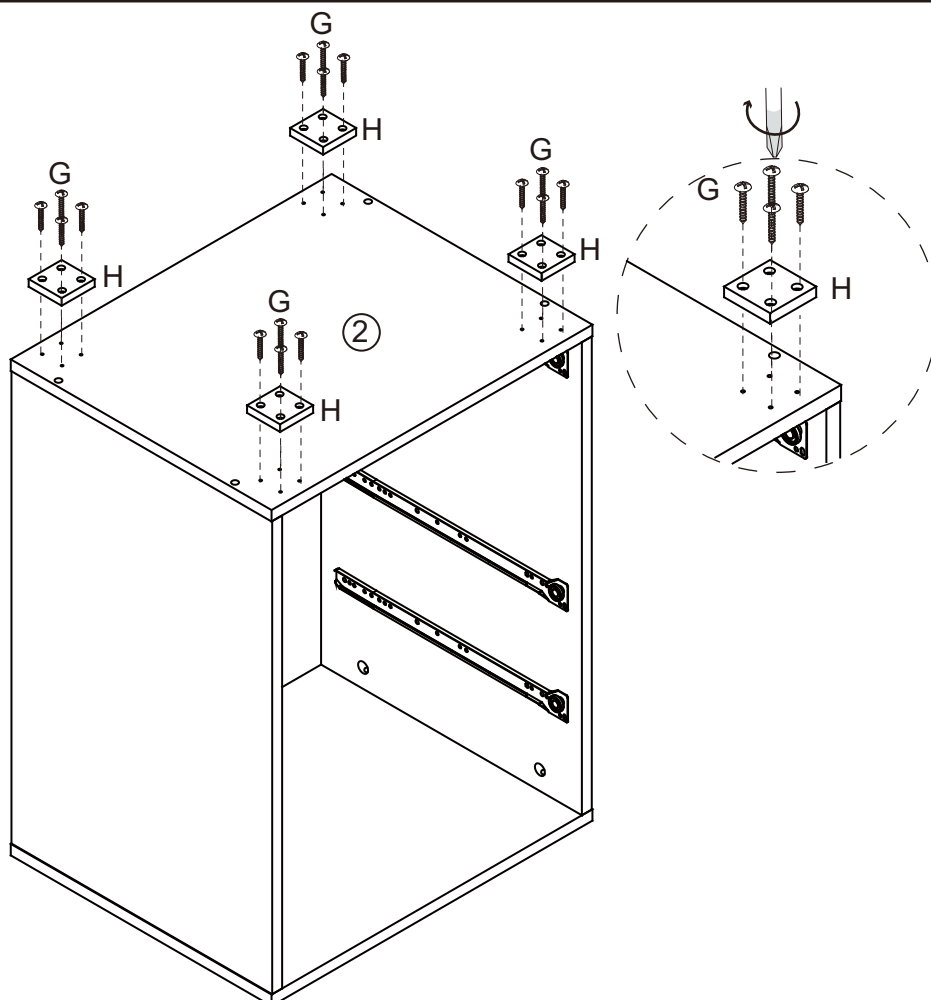

Step 7

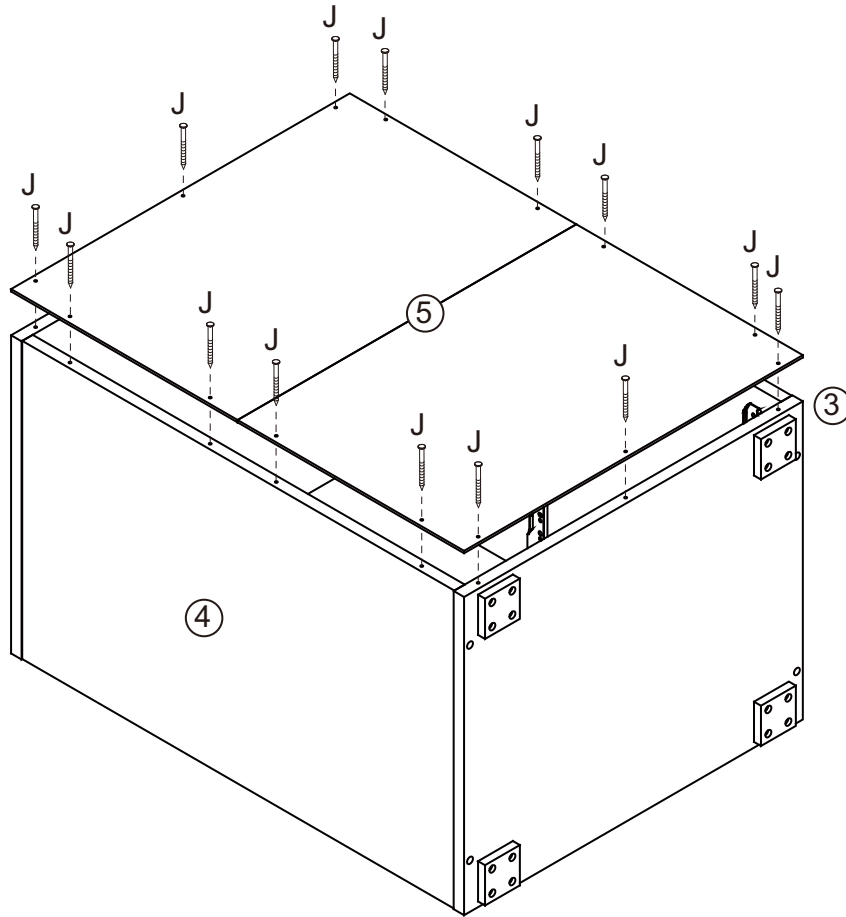

Step 8

All drawers have been pre-drilled to suit multiple handle hole spacings. If using the standard handle supplied, use the holes at 96mm hole centres marked (A) and complete the drilling process using the drill bit supplied.

Other holes have been pre-drilled to suit:
(B) centre knob
(C) 128mm handles
(D) 192mm handles

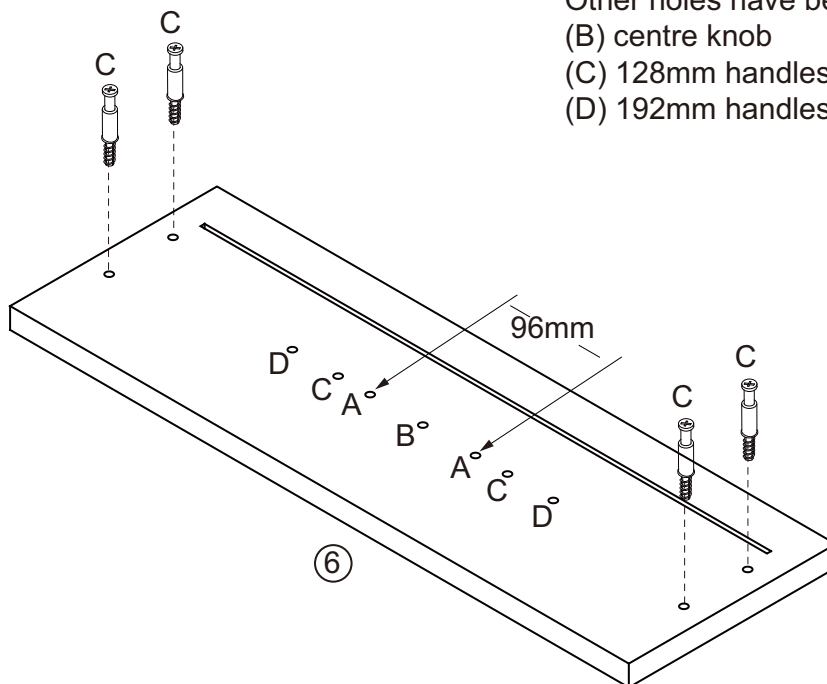

Drawer x2

Step 9

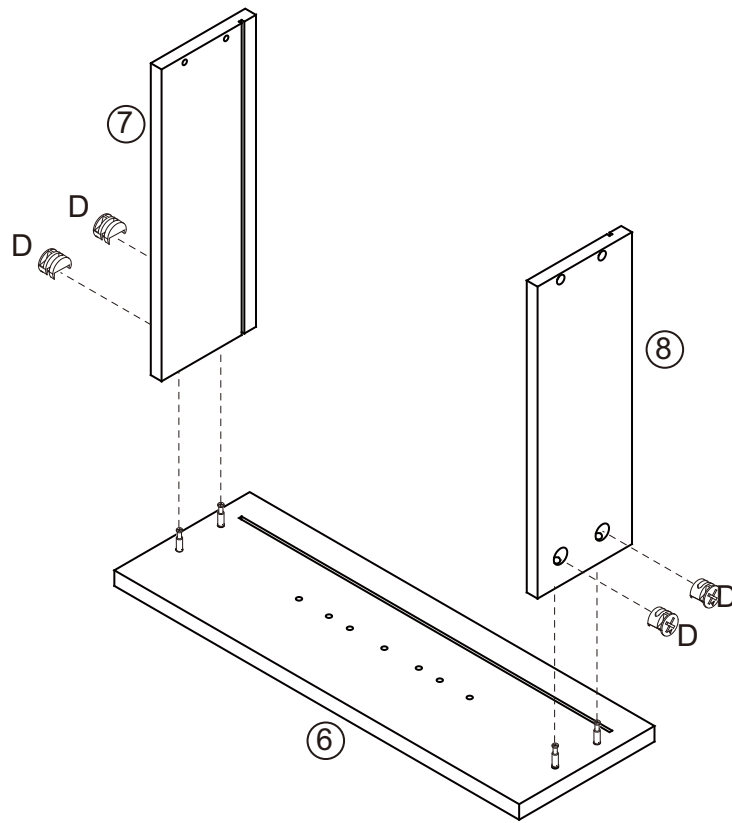

Drawer x2

Step 10

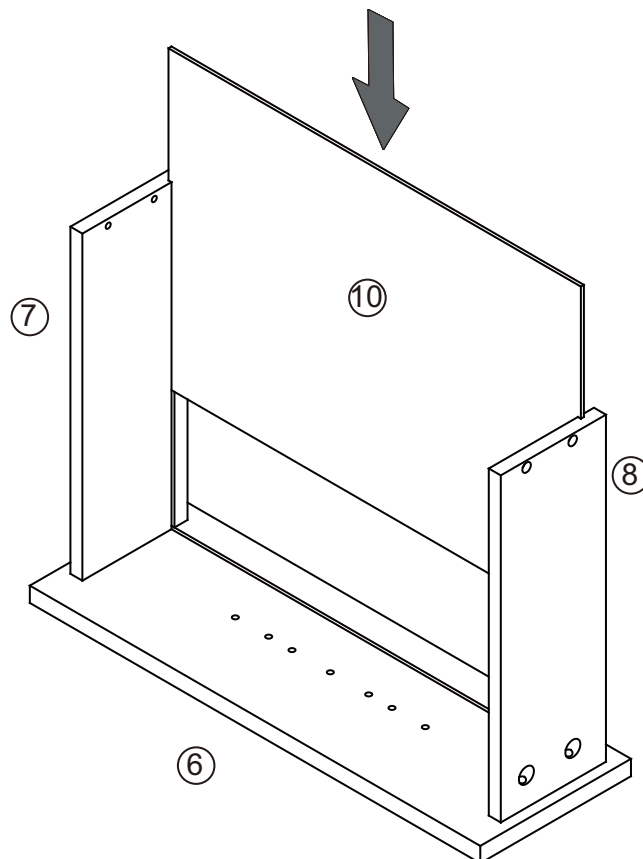

Drawer x2

Step 11

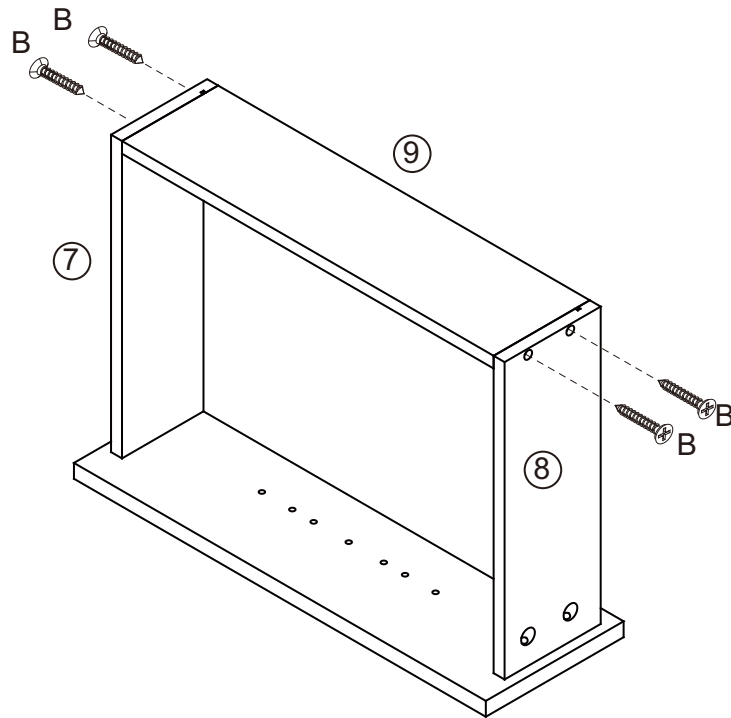

Drawer x2

Step 12

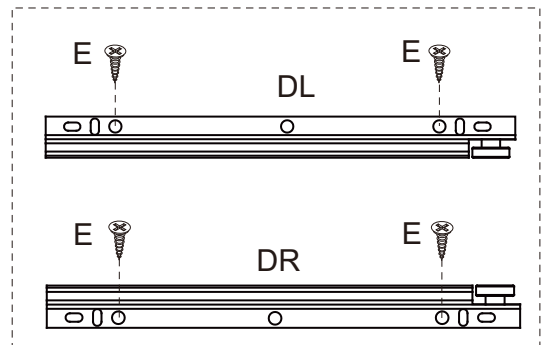
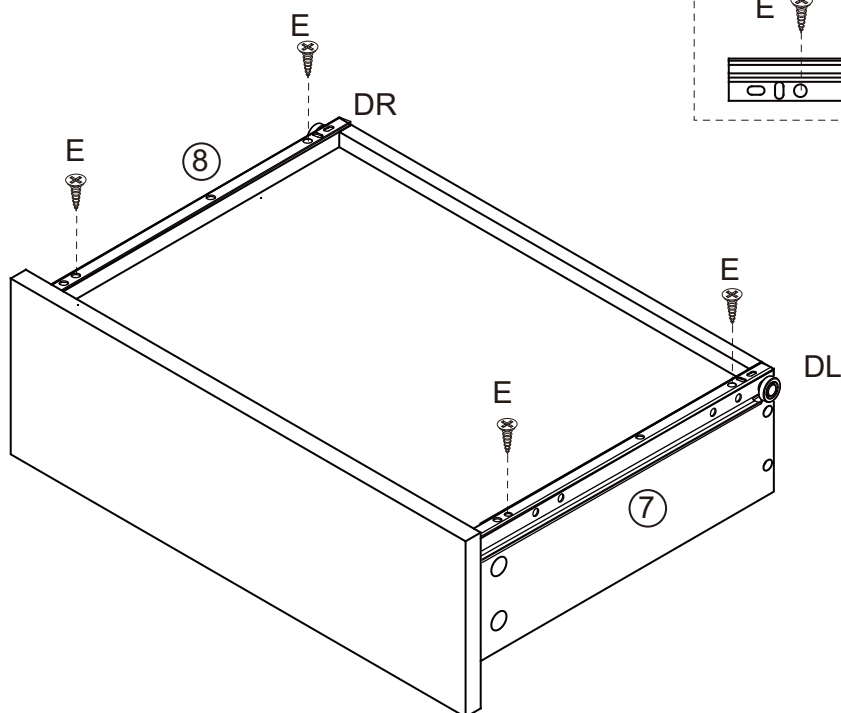

Drawer x2

Step 13

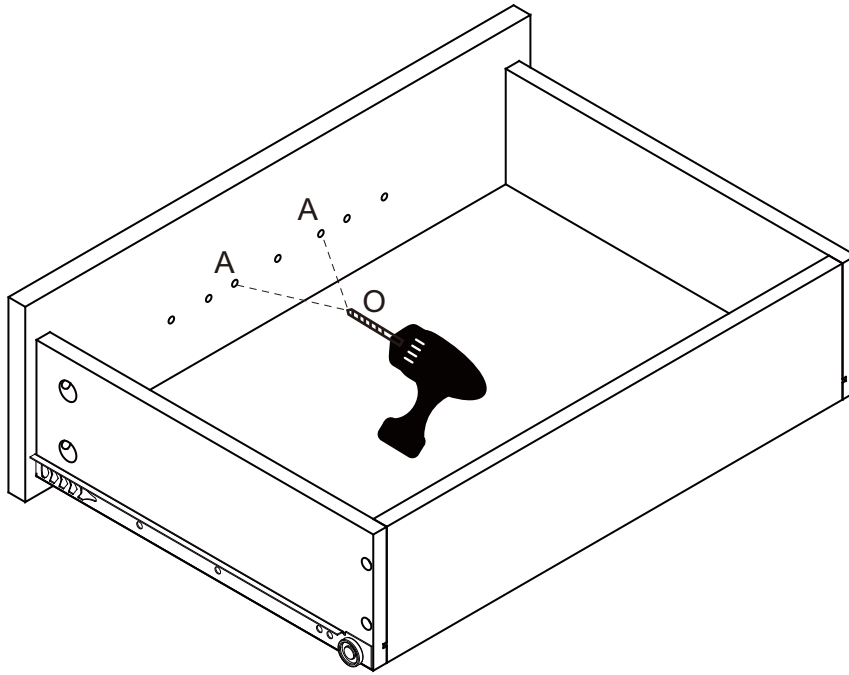

Drawer x2

* Refer to step 8 for hole drilling.

Step 14

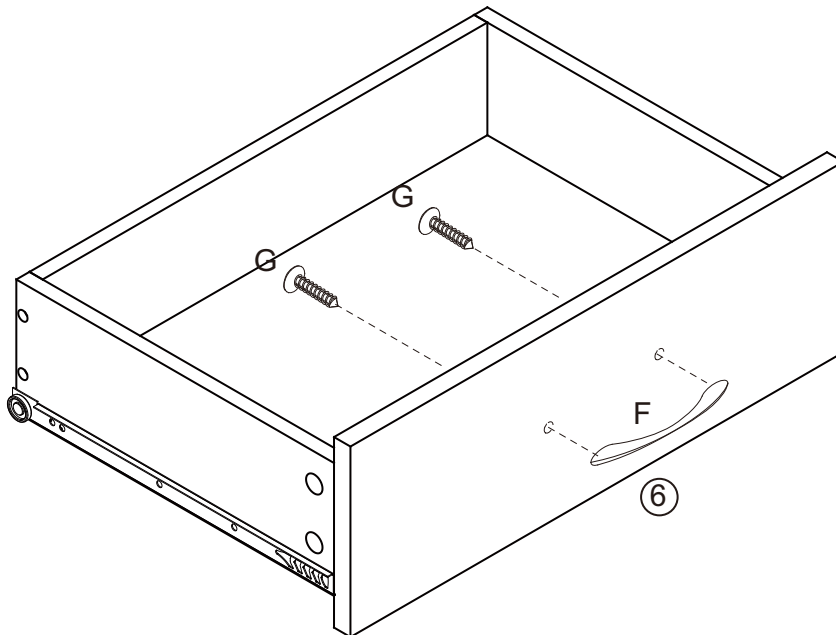

Select handle to install.

Step 15

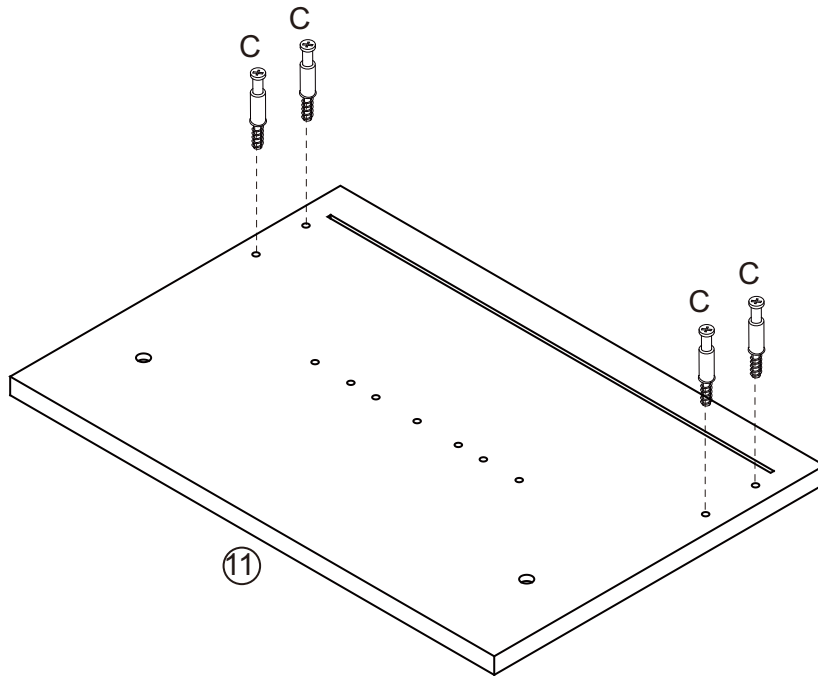

Step 16

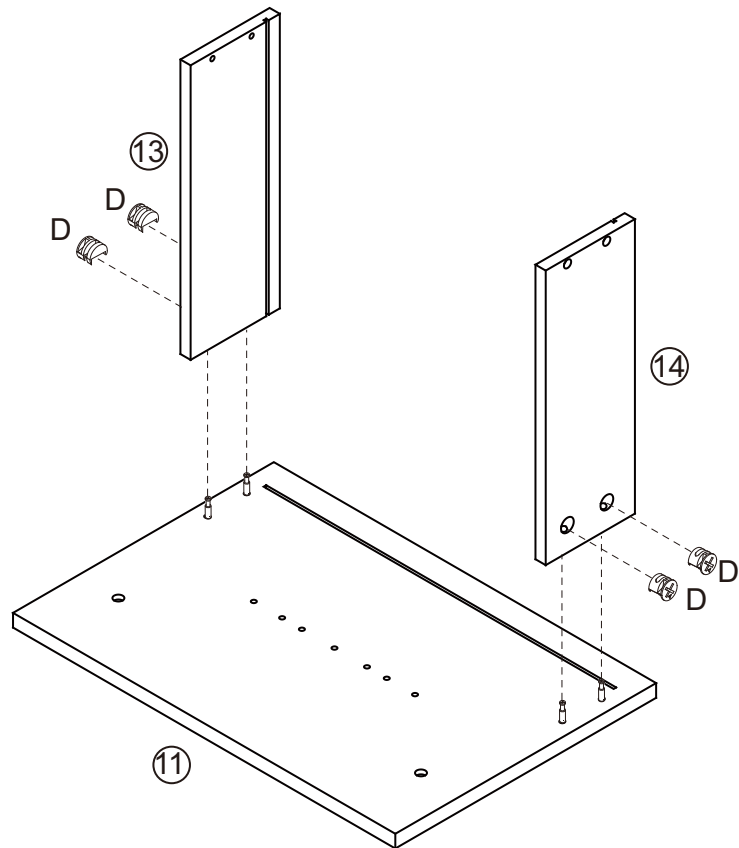

Step 17

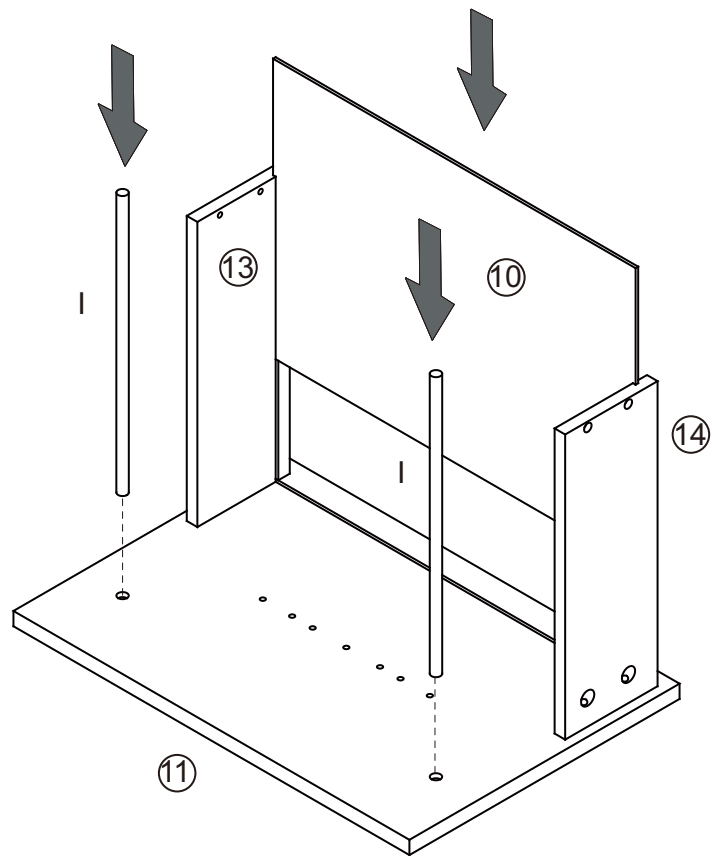

Step 18

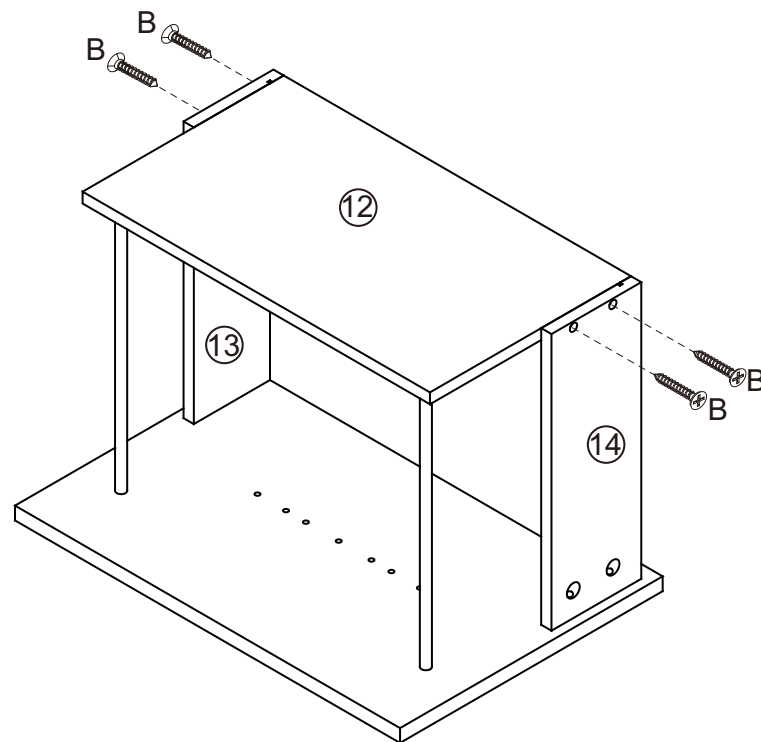

Step 19

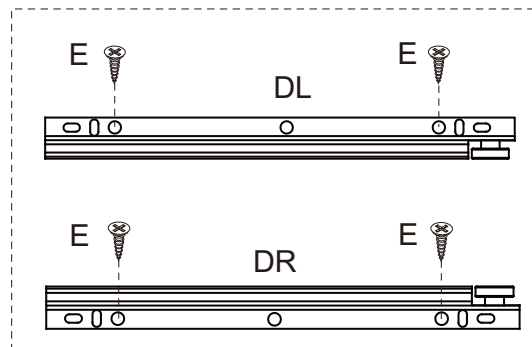
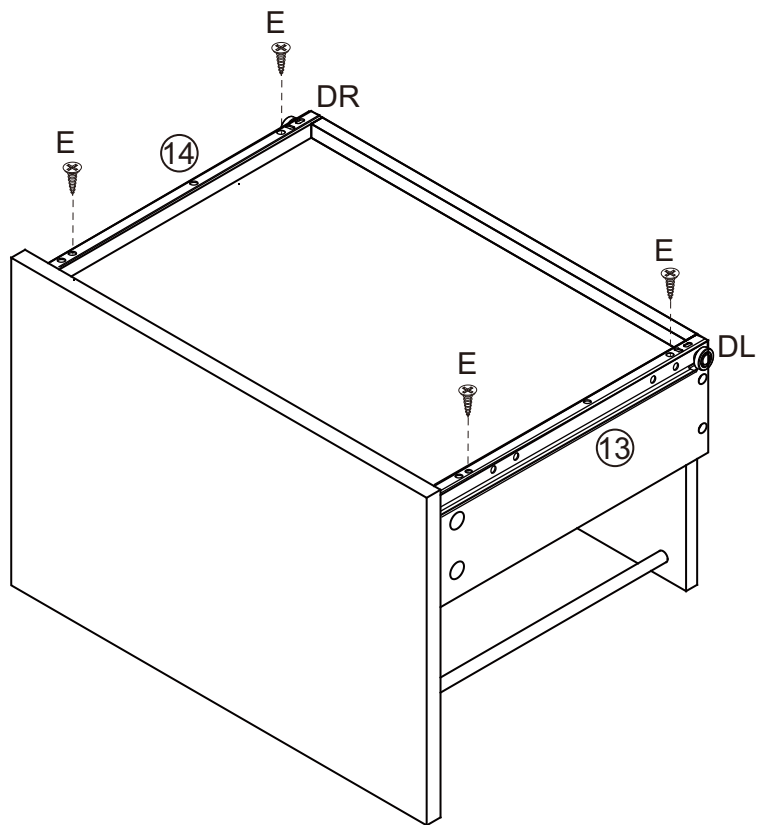

Step 20

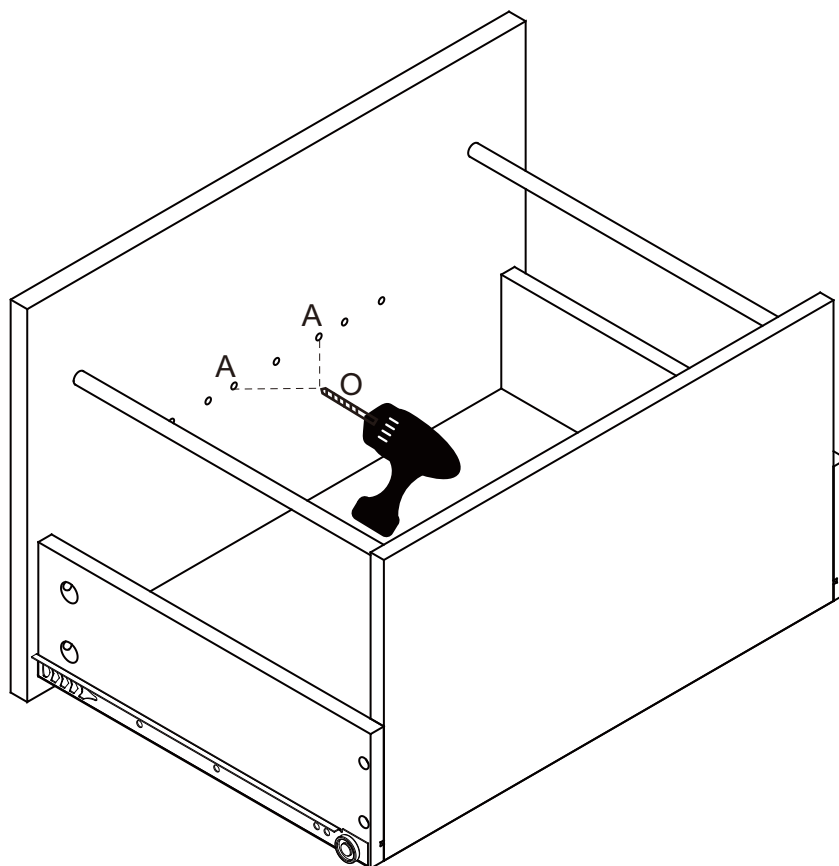

* Refer to step 8 for hole drilling.

Step 21

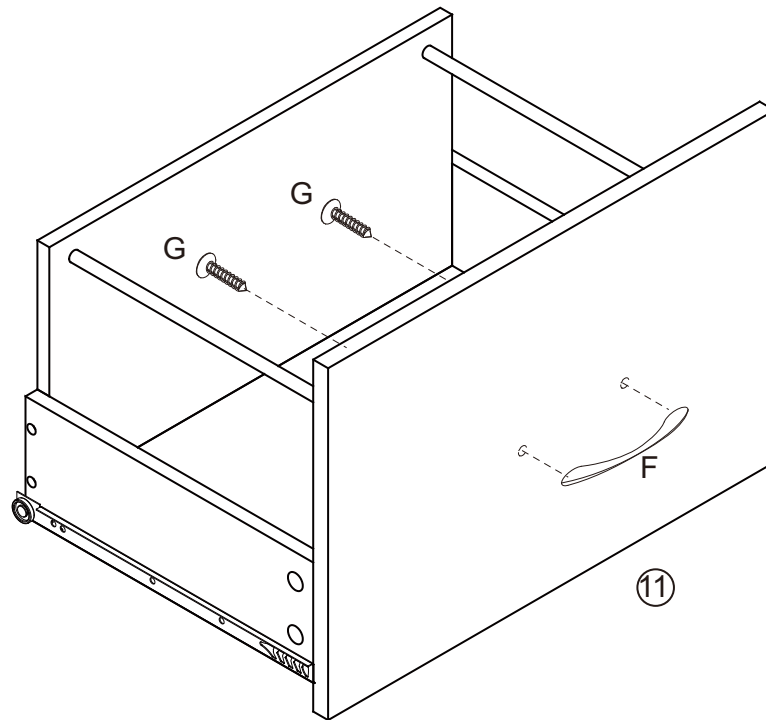

Select handle to install.

Step 22

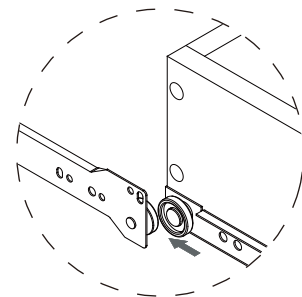
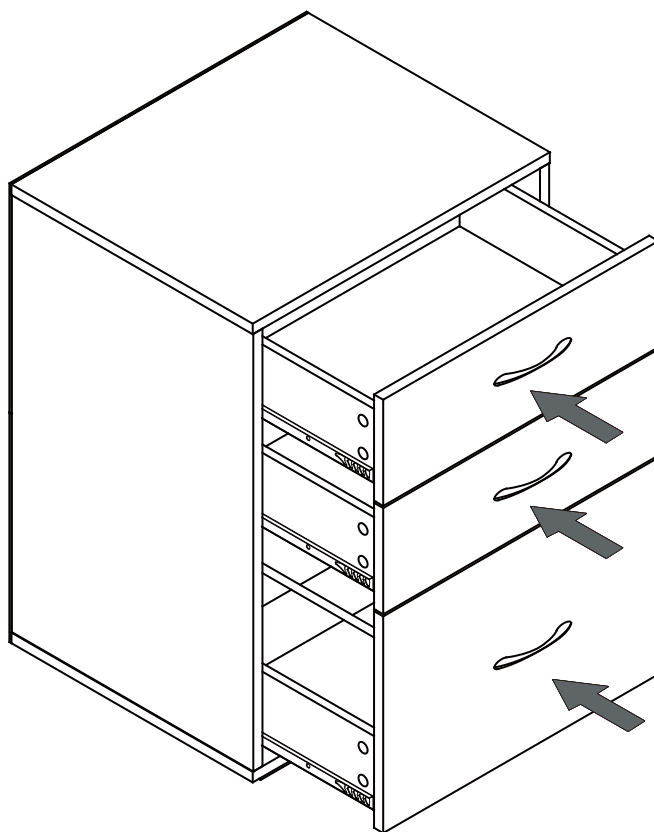

Carefully insert the drawers into the unit by gently guiding the runners into the tracks.

Step 23

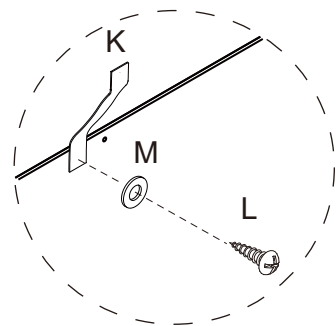
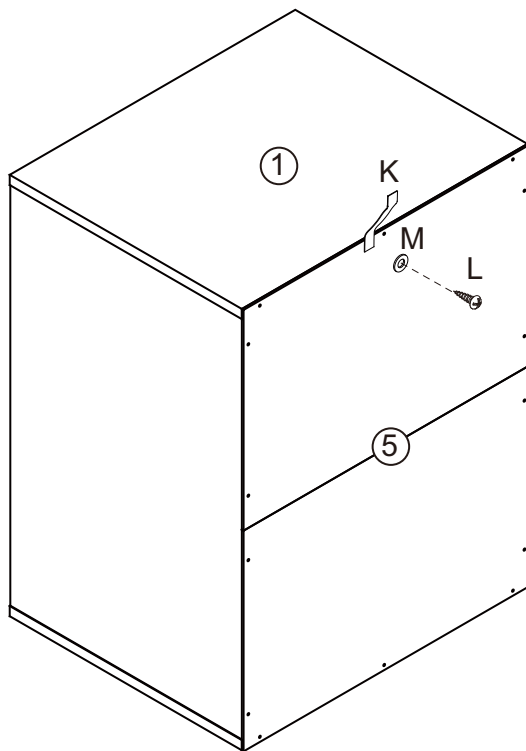

Step 24

Ensure unit is wall mounted to avoid tipping.

wall

