

5 TIER ADJUSTABLE SHELF

2090H x 1200W x 540Dmm

ITEM NO: GOS231

Very Important: Unpack the unit and confirm that you have all the parts listed. Assemble the unit on a solid, level surface. Avoid carpet. You will need the assistance of a second person during assembly.

Safety tip: For added safety and support we recommend you fix unit to a wall.

You will need the following: Rubber Mallet.

Please note: When moving shelving unit lift using the bottom leg uprights.

For evenly spaced shelves (from bottom shelf): 12 Free Keyholes, 11 Free Keyholes, 12 Free Keyholes, 11 Free Keyholes.



WARNING

SERIOUS INJURY OR DEATH CAN BE CAUSED BY TOPPLING FURNITURE

TO HELP PREVENT A TIP-OVER:

- Anchor this product to a wall or other suitable surface with the provided "Tip over prevention kit".
- Check anchors regularly

FOR MORE INFORMATION SEARCH: www.productsafety.gov.au







POWDER COATED
MATTE BLACK

180kg
PER SHELF

SAFETY TIP:

When assembling or installing this product wear protective gloves and eyewear.

Parts List

-  **MDF Shelving** x5
-  **Part A - Long Beams** x10
-  **Part B - Short Beams** x10
-  **Part C - Braces** x5
-  **Part D - Angle Posts** x8
-  **Part E - Connector** x4
-  **Part F - Rubber Feet** x8

NOT TO SCALE

PLEASE NOTE: Tip-over prevention kit included (refer to last page for installation).

Step 1



Allow one keyhole free between the foot cap and the shelving bracket.

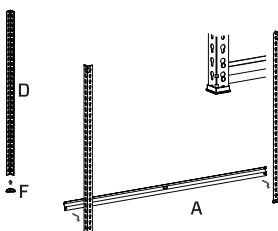

Add Rubber Feet (Part F) to bottom of 4 Angle Posts (Part D). Note upright position. Slot Long Beams (Part A) to the bottom of the Angle Posts (Part D) as shown into keyholes.

NOTE: Flat edges face outwards.

Step 2

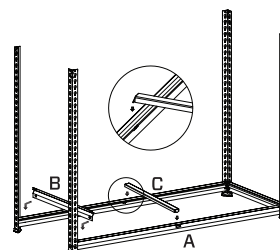

Fasten Short Beams (Part B) to the opposing keyhole of the attached Long Beam (Part A) to form a frame. Slot Brace (Part C) into position through the holes provided on the Long Beam (Part A).

Step 3

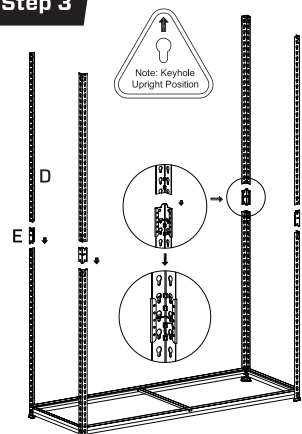

Join the upper Angle Posts (Part D) to the lower Angle Posts (Part D) with the Connector (Part E).

NOTE: The legs are designed to sit directly on top of each other - don't overlap them.

Step 4

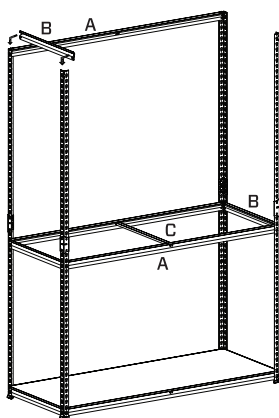

Place MDF Shelving on bottom shelf to minimise buckling. Fix Short Beam (Part B) and Long Beams (Part A) where top rivet sits on the upper Angle Posts and the bottom rivets sits on the lower Angle Post. Assemble frame at the very top allowing room for Shelving to sit flush against Angle Post.

Step 5

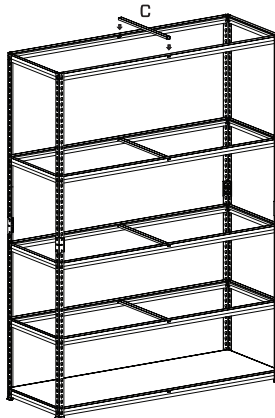

Apply remaining Beams as above to desired height. Ensure that Braces (Part C) are fixed to all shelves.

Step 6

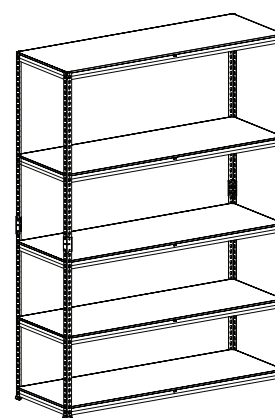

Place the MDF boards on shelves, ensure they are sitting flush against the edge of the shelf brackets.

PLEASE NOTE: Refer to next instructions below for attaching the provided Tip-over prevention kit.

WARRANTY CONDITIONS: Any claim under this warranty must be made within 1 year of the date of purchase of the product. To make a claim under this warranty, take the product (with proof of purchase) to any Bunnings store (for AUS customers see www.bunnings.com.au and for NZ customers see www.bunnings.co.nz for store locations). Pinnacle bears reasonable, direct expenses of claiming under the warranty. You may submit details and proof of purchase to our support centre for consideration. The warranty covers manufacturer defects in materials, workmanship and finish under normal use. This warranty is provided in addition to other rights and remedies you may have under law. Our goods come with guarantees that cannot be excluded under the Australian consumer law or Consumer Guarantees Act 1993 (NZ). You are entitled to a replacement or refund for a major failure and compensation for any other reasonably foreseeable loss or damage. You are also entitled to have the goods repaired or replaced if the goods fail to be of acceptable quality and the failure does not amount to a major failure. This warranty excludes damage resulting from product misuse or product neglect, any modifications, additions or alterations to the product including the addition of extra shelves. Additions or modifications can compromise the structure and safety of the product. The warranty covers domestic use only and does not apply to commercial applications. This warranty is given by Pinnacle, ABN 87 614 496 196, 45-49 Whitfield Boulevard, Cranbourne West Vic 3977, Phone: 1800 349 776, Email: support@pinnacle.net.au. Products sold in New Zealand are imported by Bunnings New Zealand. 'Pinnacle' is a trademark. © Pinnacle. Suitable for model number GOS231.

TIP OVER PREVENTION KIT:

PLEASE NOTE: We strongly recommend that this product is permanently fixed to a wall. Please use the provided “Tip over prevention kit” to securely fix product to your wall.



Parts list:

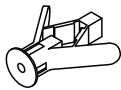

A x2



B x2



C x2



D x2

Final Step (For Brick/Masonry wall):

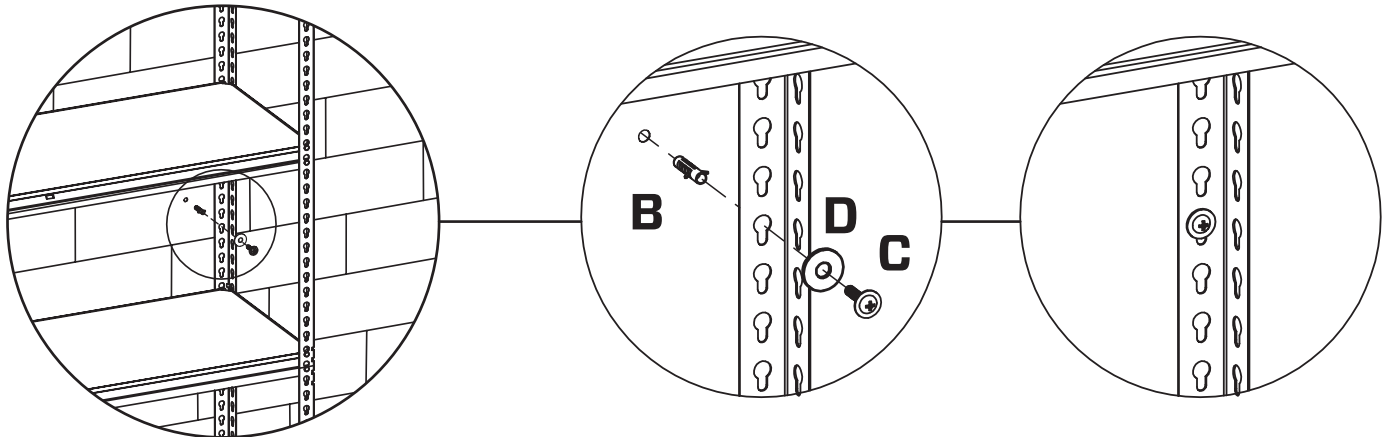

Final Step (For Plaster wall):

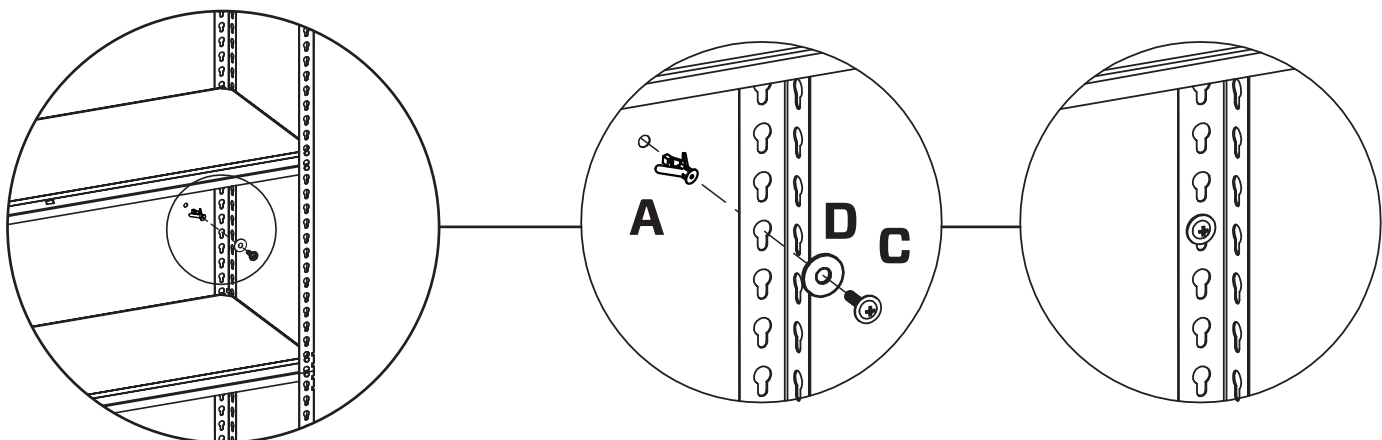

It is STRONGLY RECOMMENDED that you ANCHOR this product.

Toppling furniture can cause serious injuries and death.

A “Tip over prevention kit” has been provided with this product to stop your furniture from tipping forward, it is strongly recommended that you **securely attach this product** to a wall or other solid surface using the provided fixings.

IMPORTANT: Regularly check that anchors are securely maintained. Stability of tall items may be affected by thick pile carpet or uneven floors.

CAUTION:

For your safety when attaching the anchor fixings, please note the following:

- Check for any electrical wires or plumbing inside the wall before drilling any holes (if you are unsure please seek professional advice from a qualified tradesperson)
- Walls are constructed from different materials, for example, masonry (solid brick) or plasterboard lined cavity walls (hollow). It is important that you use the appropriate wall fixings for your wall type.