

## 5 SHELF METAL STORAGE UNIT

W 910mm x H 1830mm x D 410mm

ITEM NO: 2760578 | PART NUMBER: SHL036

**VERY IMPORTANT:** Unpack the unit and confirm that you have all the parts listed. Assemble the unit on a solid, level surface. Avoid carpet. You will need the assistance of a second person during assembly. Safety tip: For added safety and support we recommend you fix unit to a wall. **YOU WILL NEED THE FOLLOWING:** Rubber Mallet.

**PLEASE NOTE:** When moving shelving unit lift using the bottom leg uprights.

**SAFETY TIP:** For added safety and support we recommended you fix the unit to a wall.







**WARNING**

Children have died from furniture tipover.

- ALWAYS secure this furniture with an anchor device.
- NEVER allow children to stand, climb or hang on drawers, doors or shelves.

For further information visit:  
[www.productsafety.gov.au](http://www.productsafety.gov.au)

### PARTS LIST

	MDF SHELVES	X5
	BRACKETS "A"	X10
	BRACKETS "B"	X10
	LEGS "C"	X8
	CONNECTOR PINS	X4
	FOOT END CAPS	X4

NOT TO SCALE

**PLEASE NOTE:**

Tip-over prevention kit included (refer to tlast page for installation).

### STEP 1

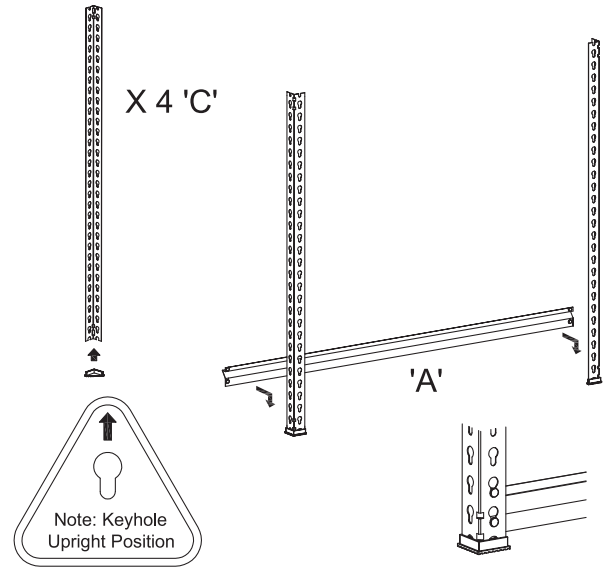

Place foot end caps onto the bottom of the 4 legs 'C'. Note upright position. Place shelving bracket 'A' onto the legs 'C'. A rubber mallet can be used to lightly tap all brackets inot the keyholes on the legs into place.

### STEP 2

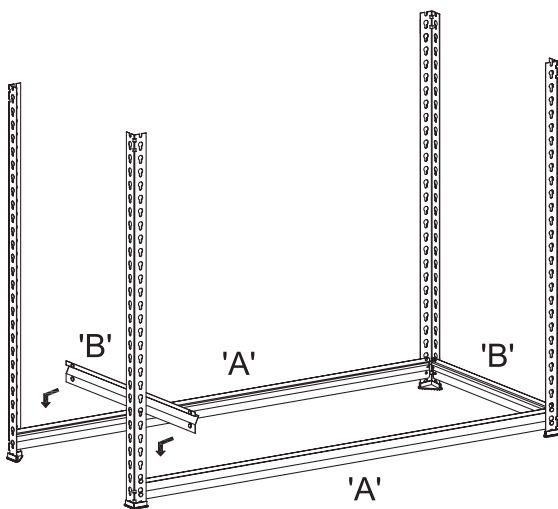

Use Shelf Brackets 'B' for the side brackets, using the Shelf Bracket from Step 1 as a guide for height. Use the same Shelving Brackets for opposing sides as shown in the diagram.

### STEP 3

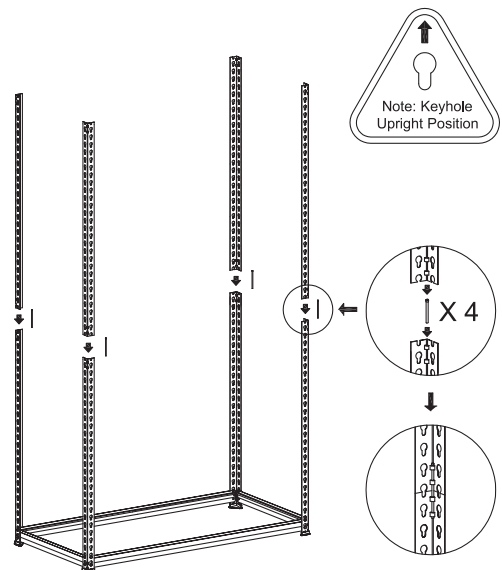

Place MDF board on bottom shelf to minimise buckling. Join the upper legs to the lower legs with the connector pins. Note upright position. Note: The legs are designed to sit directly on top of each other - don't overlap them. Handy hint: Flathead screwdriver may be used to tap in connector pins.

#### STEP 4

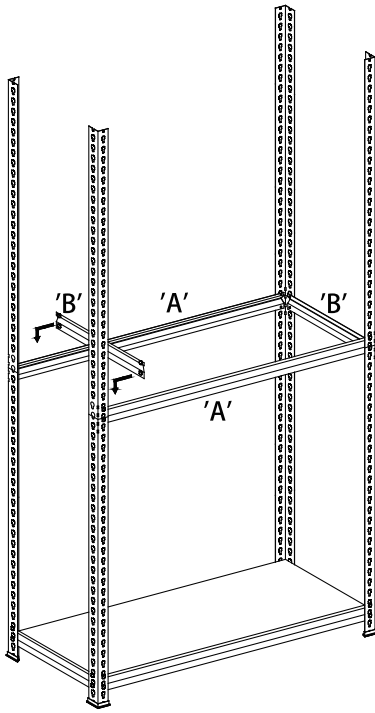

Fix brackets 'B' so that the top rivet sits on the upper legs and the bottom rivets sit on the lower legs. Repeat with Brackets 'A'.

#### STEP 5

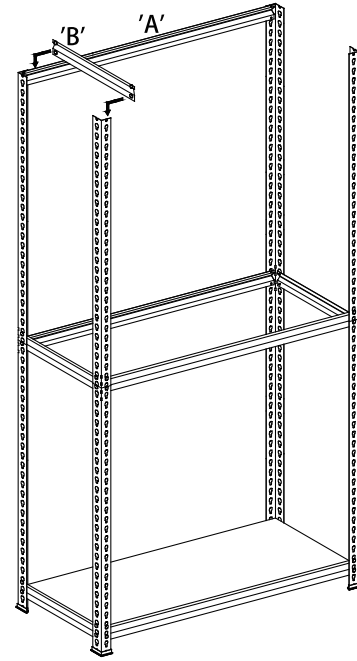

Fix brackets 'A' at the very top allowing enough room for the MDF Shelf to sit against the legs. Repeat with Brackets 'B'.

#### STEP 6

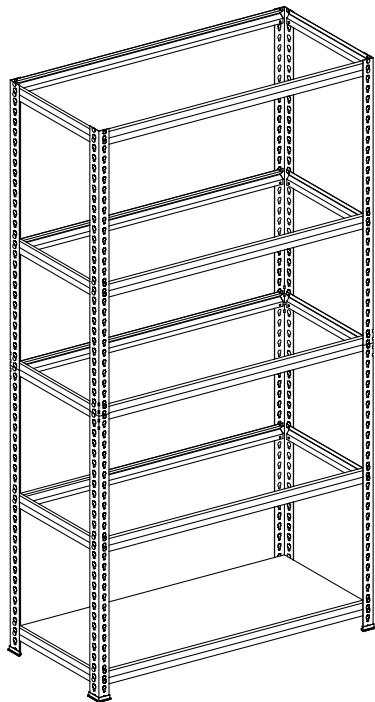

Apply remaining Brackets as above to desired height.

#### STEP 7

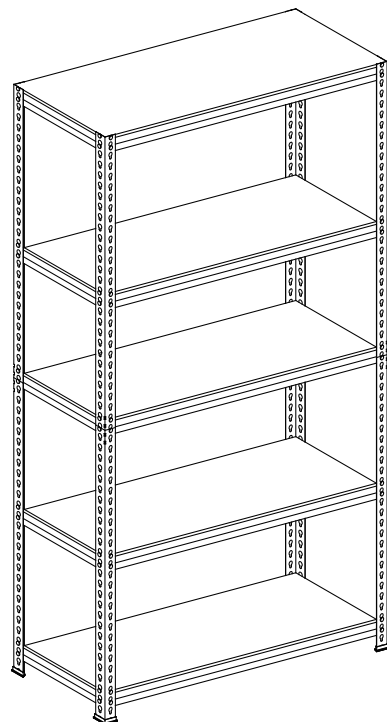

Position the MDF Shelves in place.  
**PLEASE NOTE:** Refer to next page for attaching the provided Tip-over prevention kit.

## TIP-OVER PREVENTION KIT

**PLEASE NOTE:** We strongly recommend this product is permanently fixed to a wall. Please use the provided 'Tip-over Prevention Kit' to securely fix this product to the wall.

**WARNING**



Children have died from furniture tipover.

- ALWAYS secure this furniture with an anchor device.
- NEVER allow children to stand, climb or hang on drawers, doors or shelves.

For further information visit:  
[www.productsafety.gov.au](http://www.productsafety.gov.au)

### PARTS LIST

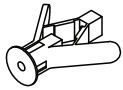

**A X2**

Hollow Wall Fixing



**B X2**

Solid Wall Plug



**C X2**



**D X2**

### FINAL STEP (FOR BRICK/MASONRY WALLS):

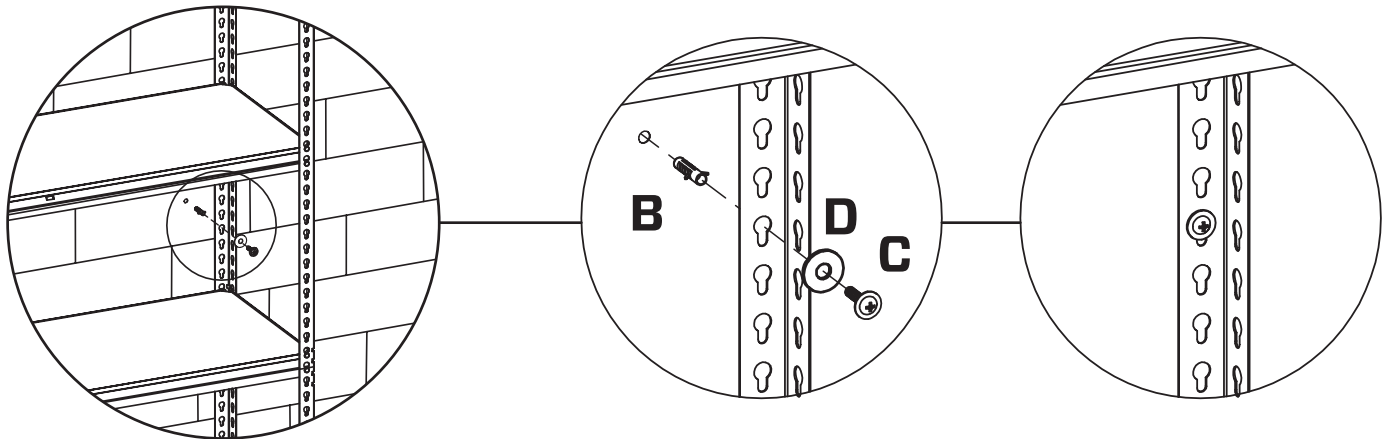

### FINAL STEP (FOR PLASTER WALLS):

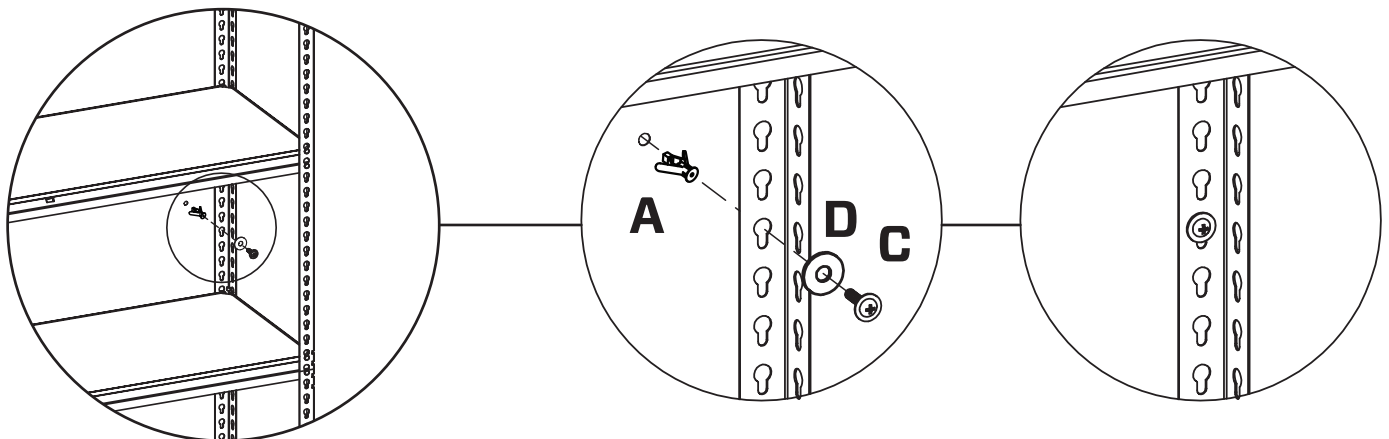

### IT IS STRONGLY RECOMMENDED THAT YOU ANCHOR THIS PRODUCT.

Toppling furniture can cause serious injuries and death.

A 'Tip Over Prevention Kit' has been provided with this product to stop your furniture from tipping forward. It is strongly recommended that you securely attach this product to a wall or other solid surface using the provided fixings.

**IMPORTANT:** Regularly check that anchors are securely maintained. Stability of tall items may be affected by thick pile carpet or uneven floors.

### CAUTION:

For your safety when attaching the anchor fixings, please note the following:

- Check for any electrical wires or plumbing inside the wall before drilling any holes (if unsure please seek professional advice from a qualified tradesperson)
- Walls are constructed from different materials. For example masonry (solid brick) or plasterboard lined cavity walls (hollow). It is very important you use the appropriate wall fixings for your wall type.