

PAN FLOOR FIXING GUIDE

1	2 X FLOOR BRACKET
2	2 X FLOOR PLUGS S10 X 50
3	2 X HEX HEAD SCREW 6 X 60
4	2 X WASHERS
5	2 X SS SCREWS 5 X 60
6	2 X NYLON BUSHES
7	2 X CAPS

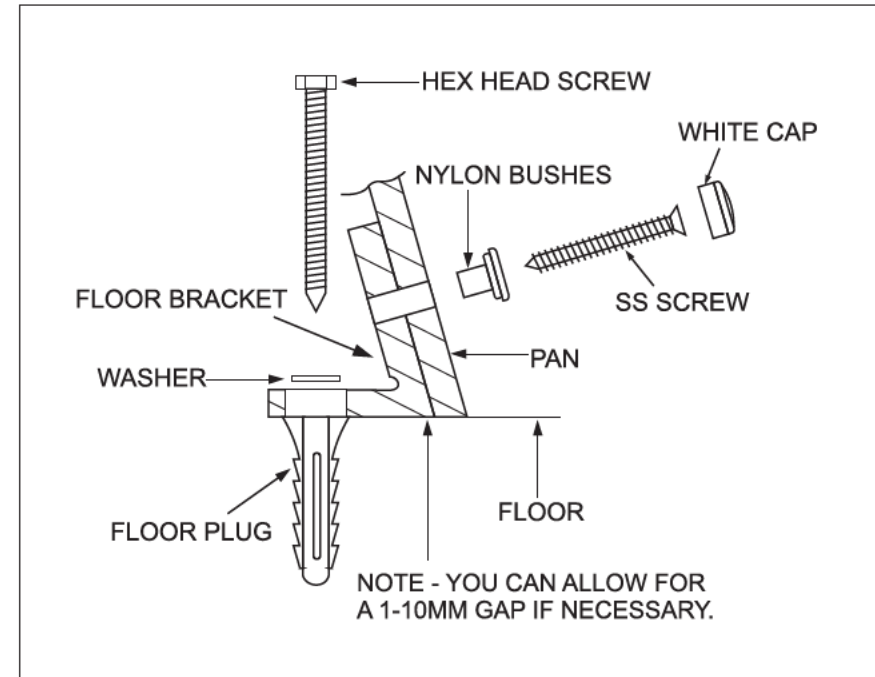

1

PLACE THE PAN INTO ITS DESIRED INSTALLATION POSITION. TRACE AROUND THE OUTSIDE OF YOUR PAN USING A PENCIL.

2

MARK OUT WHERE THE 2 HOLES ARE LOCATED ON YOUR PAN.

3

PAN OUTLINE
 PAN THICKNESS
 MARK THE CENTRE OF THE FIXING BRACKET.

REMOVE THE PAN & MEASURE THE DESIRED SCREW FIXING POINTS. REMEMBER TO ALLOW FOR THE PAN THICKNESS. A 1-10MM GAP BETWEEN THE PAN & FIXING BRACKET IS ACCEPTABLE.

4

DRILL HOLES TO CORRECT DEPTH USING AN APPROPRIATE DRILL BIT THAT SUITS YOUR FLOOR.

DRILL HOLES USING AN APPROPRIATE DRILL BIT. APPLY WET AREAS SILICONE INTO THE HOLES & TO THE BASE OF THE FLOOR BRACKET TO HELP KEEP THE FLOOR WATERPROOF. INSTALL THE FLOOR BRACKETS INTO POSITION. DON'T INSTALL SS SCREWS AT THIS POINT.