

RACK IT

1000KG

WORKBENCH CASTORS

ASSEMBLY INSTRUCTIONS

ITEM CODE: 01337

TOOLS REQUIRED: Screwdrivers,
2x Wrench/Shifters

WARNING: HANDLE CUT METAL
EDGES CAREFULLY

SAFETY TIP

When assembling or installing this product wear protective gloves and eyewear

YOUR SIMPLE 2-STEP GUIDE INTO THE WORLD OF HIGH ROLLERS

You've got this. We know because you take pride in your passions. Take care of your stuff. That's why you purchased these Rack It 1000KG Workbench Castors. You're particular. And we like that. Because we know you'll take the time to check off all the Parts listed below and to read through these Assembly Instructions before you start. Cue Farnsey (or Beyoncé - whatever lifts you). **Let's get rolling!**

CASTOR PARTS:

Take note of your Parts List here.

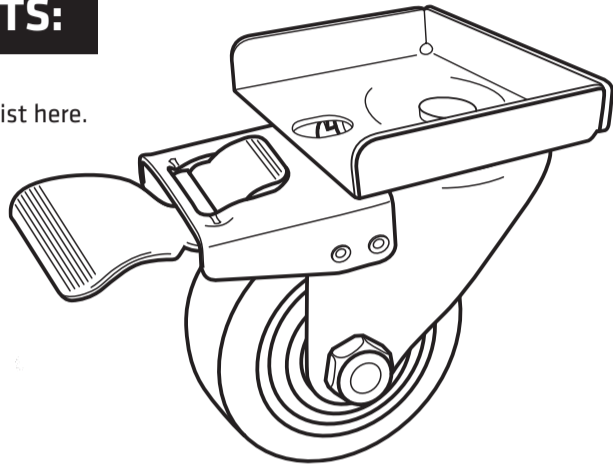

4 x Locking Castors (With Platform)

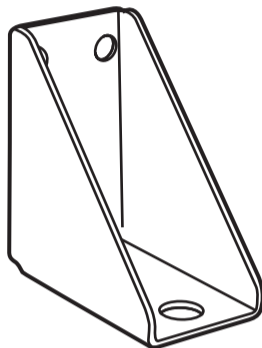

4 x Angled Braces

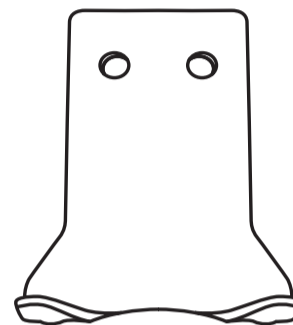

4 x Outer Braces



4 x C1 Bolts



4 x C1 Nuts

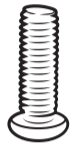

8 x B1 Bolts



8 x B1 Nuts



8 x B1 Washers

STEP 1

Remove your Workbench Top Panel. Don't be sad, it makes the thing easier to maneuver. (You'll thank us later.) Then lay your beloved Workbench on its side.

STEP 2

Engage the Brakes on all 4x Castors, so they won't swivel when it's crunch time

STEP 3

Place the Angled Brace on top of your Workbench's Foot, ensuring the single Angled Brace Hole lines up through the Foot. Insert the large C1 Bolt from the Bottom, then tighten off with the C1 Nut. Whatever you do, do not over-tighten. Repeat this Step for all 4x Castors.

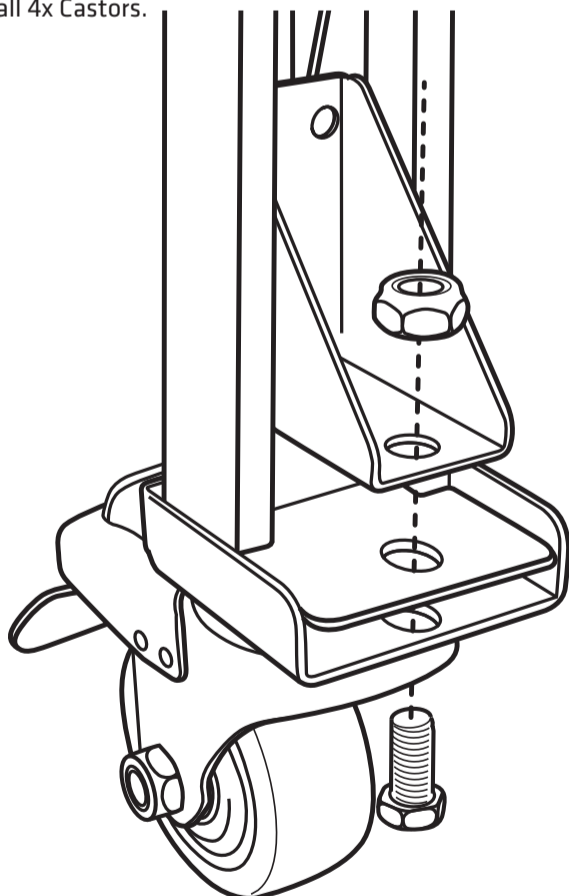

STEP 4

Place your Outer Braces over the V-shaped slots in the Uprights with the lower wings placed under the Castor platform (IMAGE 4A). Insert your 8x B1 Bolts through the Holes on the Braces and Uprights. Be sure to add B1 Washers to the outside before inserting, then fix off with your 8x B1 Nuts.

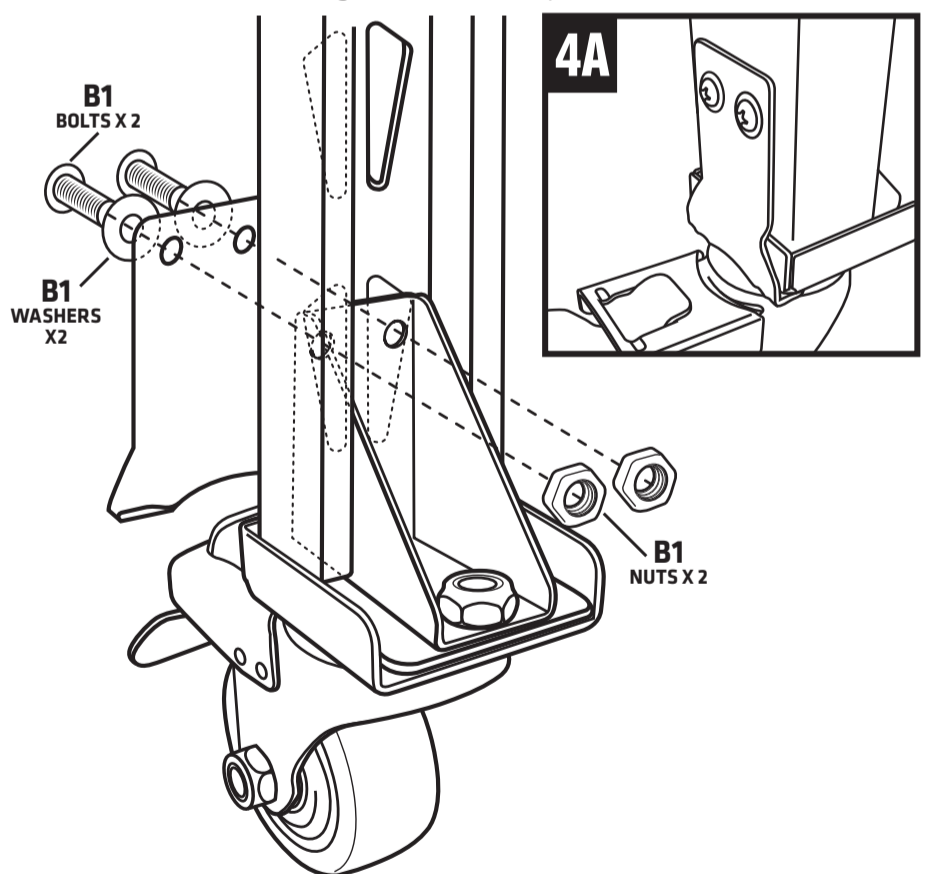

STEP 5

Grab a friend and carefully return your Workbench to its upright position. Reattach your Top Panel, release the Brakes and roll it where you'd like it.

You've done it! Cue warm inner feeling of satisfaction.

Stand back and marvel at your Rack It Workbench Castors. Give yourself (and your friend) a hi-five for the last time!

Now is the time to enjoy tossing these instructions in the recycling. **We knew you had it in you!**

MADE IN CHINA | DISTRIBUTED BY:

Visy Retail Services Pty Ltd (AU): 1300 734 714 Visy Board Limited (NZ): 0800 443 058

AUSTRALIA: RACK-IT.COM.AU

NEW ZEALAND: RACK-IT.CO.NZ