



Tools and Materials Needed

- Mitre saw (recommended) or hacksaw with non-ferrous metal cutting blade
- Spirit level
- Measuring tape
- Drill
- Drill bits for timber: 10 mm
- Drill bits for metal: 3 mm
- Philips #2 driver bit
- Socket or nutsetter: 8 mm, 17 mm
- Adjustable spanner
- Dish soap (for glass panels)
- Non-corrosive exterior silicone caulking
- Anchoring fasteners (see pages 3-4)

Fasteners Supplied



19 mm Pan head
self-drilling screw



80 mm Coach screw
with washer

See our helpful installation videos on our website:
peakbalustrade.com.au • peakbalustrade.com.nz

**Refer to the Peak Aluminium Balustrade Installation Guide
for all other installation requirements**

Dear Customer,

We'd like to take a moment to say "thank you and congratulations" for choosing our products. At Peak® your satisfaction is very important to us. That is why we work very hard to provide you with products of exceptional quality, value, and beauty. And that is also why we want to hear from you.

Please contact us with your comments or suggestions at:
support@peakproducts.com.au • support@peakproducts.co.nz

Finally, we'd like to remind you to always work safely. Then, take pride, relax with your family and experience years of enjoyment with Peak® products.

Peak Products Corporation

IMPORTANT INFORMATION

- Before beginning work, read this installation guide in its entirety including all warnings and important information.
- This installation guide is updated occasionally. Please refer to the latest version at
<https://peakproducts.com/en-au/peak-aluminium-balustrade/installation-videos-guides/>
<https://peakproducts.com/en-nz/peak-aluminium-balustrade/installation-videos-guide/>
- Maximum post spacing:
decks: 1.80 m stairs: 1.75 m
- For commercial use including multi-residential housing, please contact Peak Customer Service at:
Australia: 1300 734 714 • support@peakproducts.com.au
New Zealand: 0800 800 040 • support@peakproducts.co.nz
- Complies* with: Australian/New Zealand Standard AS/NZS 1170.0:2002 Structural design actions
* Conditions apply. For details visit:
<https://peakproducts.com/en-au/peak-aluminium-balustrade/compliance/>
<https://peakproducts.com/en-nz/peak-aluminium-balustrade/compliance/>
Complete Peak® Aluminium Balustrade system required.
- Always understand and comply with your local building codes.
- To prevent timber splitting and rot, drill pilot holes and coat fastener screw threads with non-corrosive exterior silicone caulking.
- Ensure that the opening between each of the following is less than 100 mm:
 - balusters
 - balusters and posts
 - balusters and walls
 - balusters and glass panels
 - glass panels
 - glass panels and posts
 - glass panels and walls
 - base rail and deck surface

⚠WARNING No representation or warranty is given that your particular application of these products complies with relevant building codes or that the fasteners provided or used are appropriate for your application. Consult with professionals and local building officials before beginning work: (i) to ensure compliance with relevant building codes for your application and for your proposed use of fasteners; (ii) to ensure the integrity of the structural components in connection with which these products are to be used; (iii) to identify appropriate safety gear that is to be used during installation such as a safety harness when working above ground; (iv) to ensure that the work area is free from utilities, services and hazards; and (v) to clarify any instructions or warnings that may not be clear. Work in a safe manner wearing protective gear such as gloves, eyewear, headwear, footwear and clothing. When using tools comply with operation manuals and instructions. Metal and glass may have sharp edges and could fragment or splinter during or as a result of handling or cutting. Do not use these products in connection with any substance that is or may be harmful or corrosive to the products. Inspect and maintain these products and the structural components that they are used in connection with on a regular basis, using professionals when appropriate.

Peak Products Corporation shall not be liable for any loss or damage resulting from the improper installation or improper use of this product, subject to any contrary provision of the Australian Consumer Law in Australia or the Consumer Guarantees Act in New Zealand. Peak products and associated materials are protected by patents, designs, copyrights and/or trademarks used under license from Peak Innovations Inc.

ANCHORING FASTENERS FOR AUSTRALIA



⚠WARNING Engineering design has determined appropriate fasteners for the attachment of the post base, wall bracket, and base rail support to concrete or timber structures designed by others. While the types of material are defined in the table below, the ability of the supporting structure to provide adequate support to Peak® Aluminium Balustrade system and its fasteners must be independently verified for each installation. To meet certain balustrade load requirements within AS/NZS 1170.1:2002, use the fasteners specified in the tables below. Building codes may vary. Always understand and comply with your local building codes.

For further information visit: <https://peakproducts.com/en-au/peak-aluminium-balustrade/compliance/>

POST BASE Typical Anchoring Fasteners			
Deck Structure	Fasteners Required	Minimum Embedment ¹	Minimum End and Edge Distance
JD3 Timber e.g. Seasoned, Mixed Australia Hardwood	4 x M10 Coach Screw ²	100 mm	End of Joist: 50 mm Edge of Joist: 40 mm
J3 Timber e.g. Unseasoned, Mixed Australian Hardwood	4 x M10 Coach Screw ²	125 mm	End of Joist: 50 mm Edge of Joist: 40 mm
JD4 Timber e.g. Seasoned, Mixed Softwood Species	4 x M10 Coach Screw ²	145 mm	End of Joist: 50 mm Edge of Joist: 40 mm
J4 Timber e.g. Unseasoned, Pine, Radiata, Australia	4 x M10 Coach Screw ²	185 mm	End of Joist: 50 mm Edge of Joist: 40 mm
Concrete, Minimum strength 25 MPa	4 x Ramset™ WERCS Ankascrew™ or Ramset™ Ankascrew™, M10 x 100 mm	72 mm	70 mm

BASE RAIL SUPPORTS FOR GLASS PANEL ⁴ Typical Anchoring Fasteners			
Deck Structure	Fasteners Required	Minimum Embedment ¹	Minimum End and Edge Distance
JD3, J3, JD4, J4 Timber e.g. Seasoned/Unseasoned Mixed Australian Hardwood, Mixed Softwood, Pine, Radiata, Australia	2 x M6 Coach Screw ² (provided with product)	35 mm	End of Stud: 49 mm Edge of Stud: 25 mm
Concrete, Minimum strength 25 MPa	2 x Ramset™ Ankascrew™ M5 x 30 mm	25 mm	40 mm

¹ Depth of the threaded portion of the screw into the innermost member.

² Material of steel coach screws shall be given in AS/NZS 4291.1, for property classes 4.6 and 4.8.

³ Material of 14g Type 17 screws shall be given in AS 3566.

⁴ 'Base Rail Supports for Glass Panel' applications are limited to; maximum AS/NZS 1170.2 Design Ultimate Wind Pressures of 4.02 kPa; and, AS4055 N1, N2, N3, N4, C1 & C2 buildings based on equivalent wall pressures.

GLASS PANEL INSTALLATION

! This symbol indicates important information.

! Always use two people to handle glass panels. Always lift a glass panel by its sides. Toughened glass is extremely fragile – do not bump the edges. Always use protective gear including eyewear and gloves when handling glass panels.

1 Measure and mark the position of all posts and space equally.

! Maximum post spacing 1.80 m for 2.5 kPa design wind pressure (1.20 m for 4.02 kPa design wind pressure). For details visit:
<https://peakproducts.com/en-au/peak-aluminium-balustrade/compliance/>
<https://peakproducts.com/en-nz/peak-aluminium-balustrade/compliance/>

Put the first post in position. For timber attachment, secure post to deck using four M10 coach screws (refer to page 3 for required length) through each corner of the post base. Ensure that the post is plumb.

! To prevent splitting of deck boards, drill four 10 mm holes through deck boards (but not into deck structure).

! To prevent timber rot, coat fastener screw threads with non-corrosive exterior silicon caulking.

! For concrete attachment, refer to page 3 for anchoring fastener recommendations.

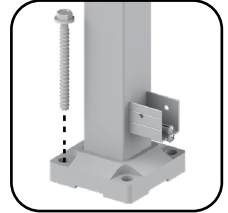

2 **A:** Remove the plastic baluster gaskets from both rails.
B: Temporarily position the second post but do NOT secure it yet. Cut the hand and base rails to fit between the posts.

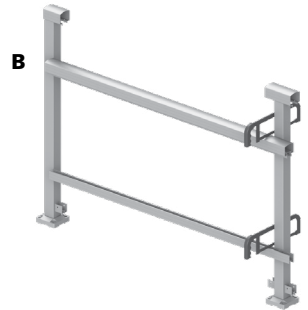
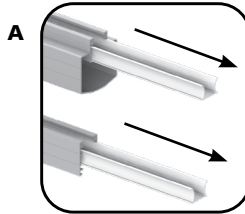

3 **A:** Cut the glass gaskets the same length as the rails.
B: Drill 3 mm holes into the base rail glass gasket (the smaller gasket) every 300 mm for water drainage.
C: Press the glass gaskets into the rails.
! The smaller of the two glass gaskets goes into the base rail.

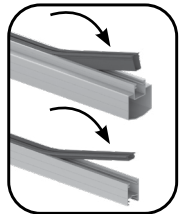
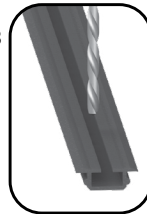
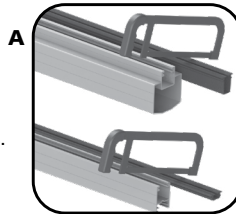

4 Position second post and two base rail supports, then insert handrail and base rail into posts and base rail supports.

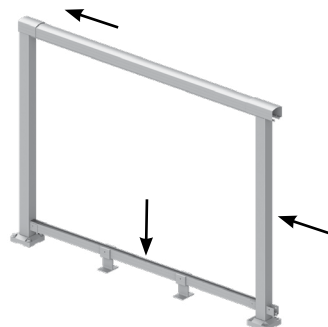

- 5** **A:** Fasten the second post in place, ensuring that the post is plumb (see step 1 for full details).
B: Slide base rail supports to the third positions (space them equally).
C: Secure base rail supports to the base rail using 19 mm pan head self-drilling screws.
D: For timber attachment, fasten base rail supports to the deck using two 80 mm coach screws each.

⚠ For concrete attachment, refer to page 3 for anchoring fastener recommendations.

⚠ To ensure the glass panel remains engaged in the rails, you must install two base rail supports for each balustrade section.

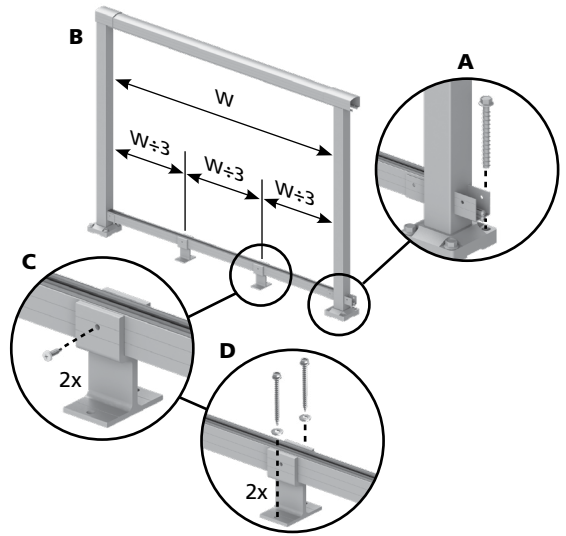

- 6** Secure the rails to both posts with 19 mm pan head self-drilling screws.

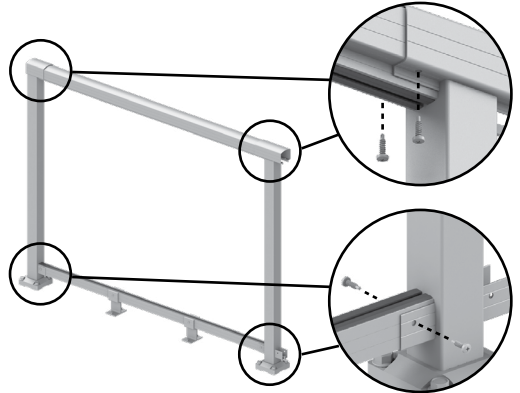

- 7** Install the glass panel by inserting it into the handrail gasket then lowering it into the base rail gasket.

⚠ Ensure that the glass gaskets and the top and bottom edges of the glass panel are well lubricated with liquid soap before installing the glass panel.

⚠ Ensure that the glass is fully seated in the gaskets. Wash away excess soap with clean water.

⚠ The opening between a glass panel and a post must not exceed 100 mm.

⚠ Maximum of one glass panel between posts.

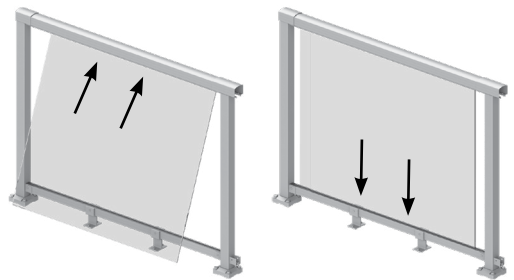

- 8** Repeat all steps for remaining sections.

⚠ Optional: Install post base covers.

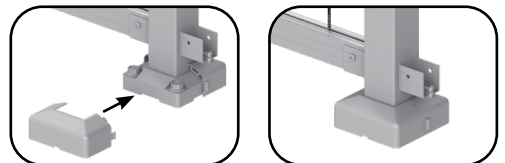

WALL BRACKET INSTALLATION

 This symbol indicates important information.

1 Measure and mark the position of all brackets on the wall.

 Maximum wall bracket spacing of 1.80 m.

2 For timber attachment, secure hand and base rail brackets to wall using four M6 coach screws with washers.

 To prevent timber rot, coat fastener screw threads with non-corrosive exterior silicone caulking.

 For concrete attachment, refer to pages 3-4 for anchoring fastener recommendations.

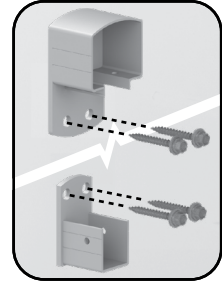
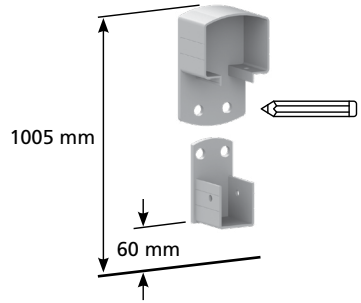

3 Follow the **Glass Panel** installation process as shown on pages 4-5.

HORIZONTAL ANGLE BRACKET INSTALLATION

 This symbol indicates important information.

1 Measure and mark the hole positions of all brackets on the post.

 Maximum post spacing of 1.80 m.

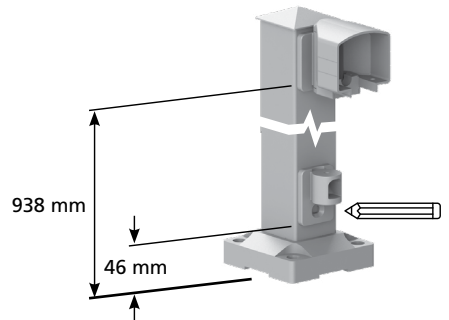

2 **A:** Drill 5.5 mm pilot holes at the marked locations.

B: Attach the hand and base rail brackets to the post using four 25 mm flat head screws. Then assemble the base rail bracket using the connector bolt.

3 Follow the **Glass Panel** installation process as shown on pages 4-5.

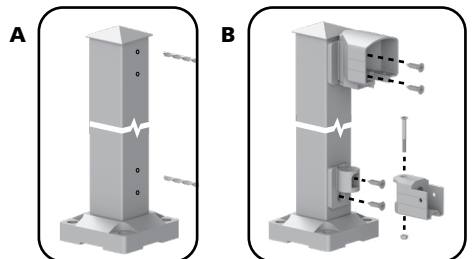

GATE INSTALLATION

 This symbol indicates important information.

 Before beginning work, measure and ensure the Gate Opening (W) does not exceed 1150 mm. Then please carefully follow the steps below to ensure the gate is not cut too short for your project.

- 1**
- A:** Remove latch side of gate frame.
 - B:** With latch side of gate frame removed, cut top and bottom gate rails 190 mm shorter than gate opening W.

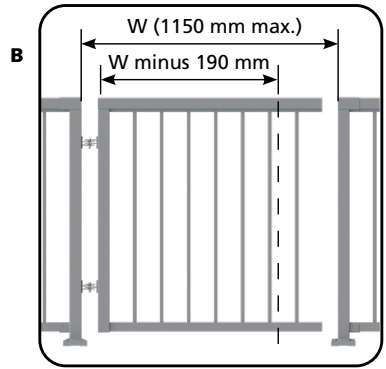
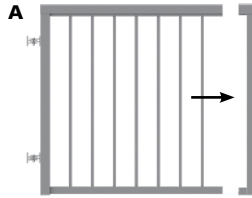

- 2**
- Attach the latch side of the gate frame using the 19 mm pan head self-drilling screws.

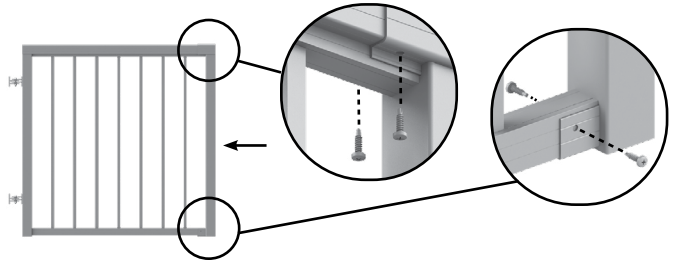

- 3**
- A:** Align the top of the gate with the top of the post and mark the hole positions for the hinges on the post.
 - B:** Drill 5.5 mm pilot holes at the marked positions.
 - C:** Install the top 50 mm coach screw on each hinge.
 - D:** Install the bottom 50 mm coach screw on each hinge by releasing the bolt and nut (HINT: do not completely disassemble hinge).

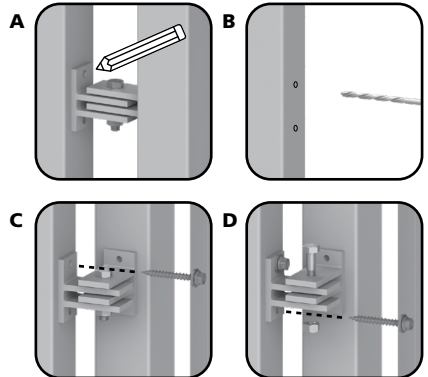

- 4**
- Use 19 mm pan head self drilling screws for these steps:
- A:** Secure the retainer to the gate at the marked position.
 - B:** Insert the latch through the retainer.
 - C:** Secure the latch to the gate at the marked position.
 - D:** Check and mark the position for the latch plate on the post. Secure the latch plate to the post.

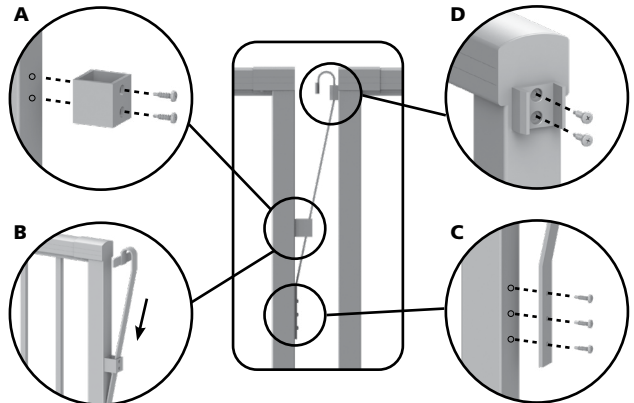

NOTES