



MATADOR™



TEMPO 3

3 Burner Portable BBQ

Model: BG323-3B

Retain manual for future reference.



CONTENTS

FEATURES AND BENEFITS	3
IMPORTANT SAFETY WARNINGS	4
GAS LEAK TEST	5
IMPORTANT SAFETY INSTRUCTIONS	6
GAS LEAK STEPS	7
EXPLODED PARTS VIEW	8
PARTS LIST	9
BOLT PACK	12
ASSEMBLY STEPS	13
BBQ LOCATION – OUTDOOR AREA	23
CONNECTION TO LPG	25
LIGHTING PROCEDURE	26
CLEANING AND MAINTENANCE	28
STORAGE	32
CONNECTION TO NATURAL GAS	34
SPECIFICATIONS	35
WARRANTY	36



FEATURES & BENEFITS

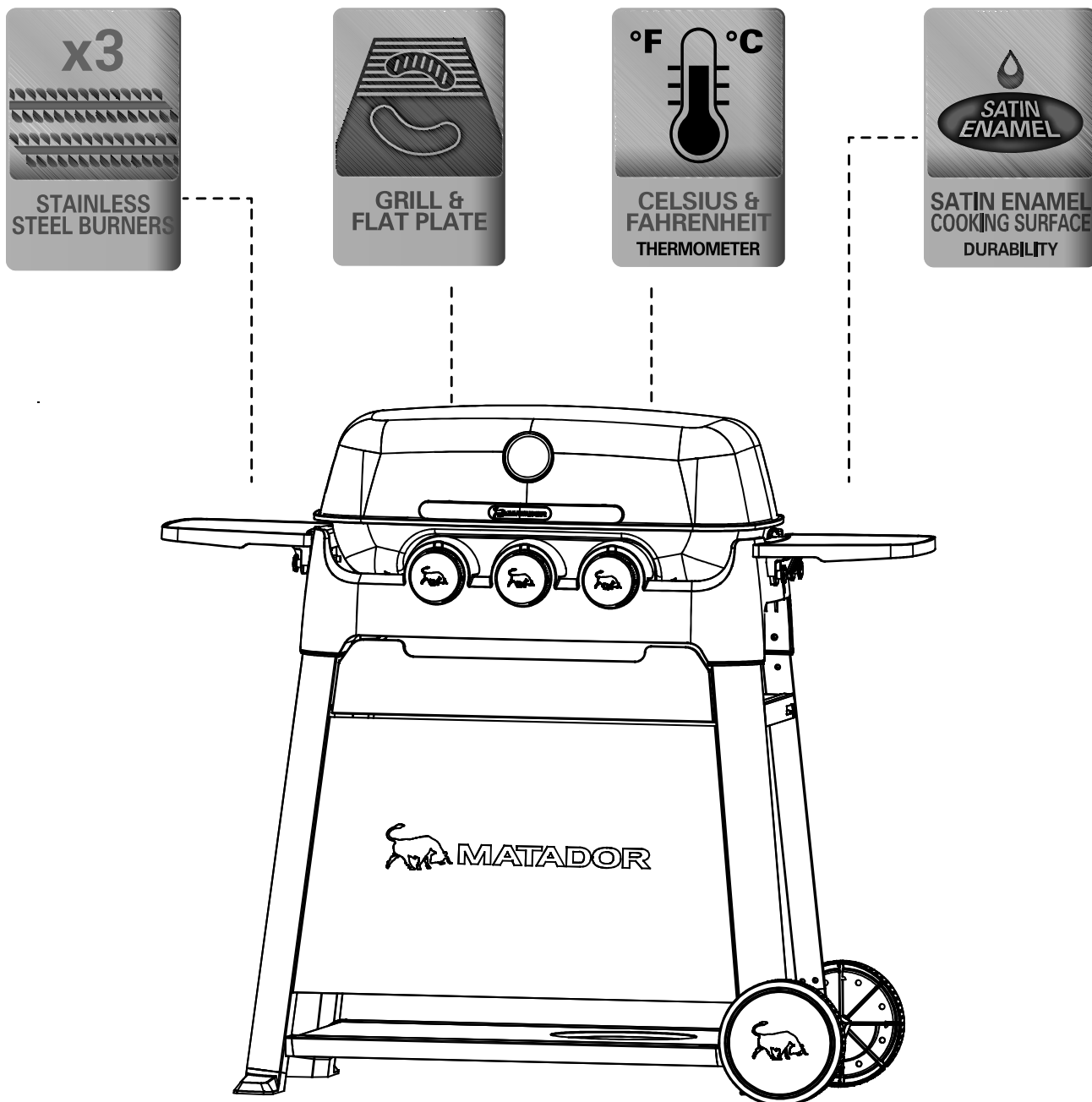

Overall Barbecue Dimensions

3B Freestanding	Length	Height	Depth
	1250	1080	600

Gas Output

Gas Type	Burner	
	Middle	Sides
LPG / U-LPG	8.0MJ/h	9.5MJ/h
Natural Gas	8.0MJ/h	9.5MJ/h

BBQ ASSEMBLY & OPERATION INSTRUCTIONS

3 BURNER PORTABLE BBQ – MODEL BG323-3B

Important! Please read these instructions carefully before use!

FOR OUTDOOR USE ONLY

IF YOU SMELL GAS:

1. Shut off gas to the BBQ at the cylinder.
2. Open hood.
3. Extinguish any flames.
4. If odour continues, immediately call your gas supplier.

FOR YOUR SAFETY

1. Do not store or use gasoline or other flammable vapors or liquids in the vicinity of this or any other appliance.
 2. An LPG cylinder not connected for use shall not be stored in the vicinity of this or any other appliance.
- Improper installation, adjustment, alteration, service or maintenance can cause property damage, injury or death. Read the installation, operating and maintenance instructions thoroughly before installing or servicing this equipment.
 - Warning: accessible parts may be very hot. Keep young children away.
 - Do not move the appliance during use.
 - Turn off the gas supply at the gas cylinder after use.
 - Any modification of the appliance may be dangerous.
 - Installer to leave instructions with the consumer and consumer to retain them for future reference.
 - Do not replace the grill with an extra hotplate. The warranty will be void and it violates the gas approval, the grill provides the ventilation needed for the BBQ to operate safely. It is not designed to be a solid hotplate device.
 - Please ensure all packaging and transit protection materials are removed prior to using the BBQ.



DO NOT OPERATE THIS APPLIANCE BEFORE READING THE INSTRUCTION BOOKLET

DO NOT PLACE ARTICLES ON OR AGAINST THIS APPLIANCE

DO NOT STORE CHEMICALS OR FLAMMABLE MATERIALS OR SPRAY AEROSOLS NEAR THIS APPLIANCE

DO NOT OPERATE THIS APPLIANCE INDOORS

DO NOT ENCLOSE THIS APPLIANCE

DO NOT LIGHT OR OPERATE WITH COVER ON



GAS LEAK TEST

Gas connections on the Barbecue are leak tested at the factory prior to shipment however, you must complete gas leak test during assembly and every time you connect the regulator to an LPG cylinder.

1. Make a soap solution using one part liquid detergent and one part water.

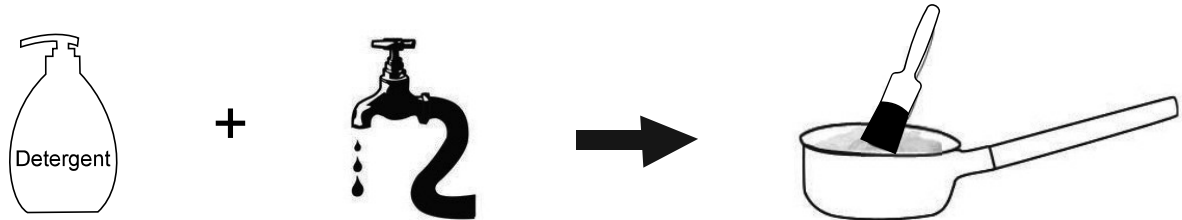

2. Connect the regulator to an LPG cylinder then open the cylinder valve.

3. Apply the soap solution to the gas connections using a soft bristle brush.

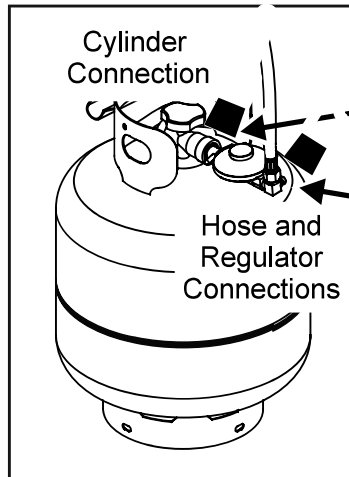
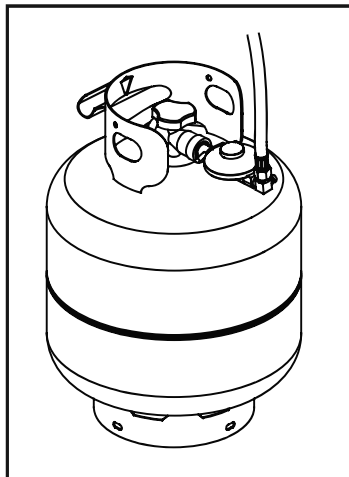

Soap bubbles will appear if there is a gas leak. In case of a leak, turn off the gas supply. Tighten any leaking fittings, then turn the gas supply on and re-check.
Warning:
Do not operate the appliance until all gas leaks have been rectified. Never leak test while smoking.

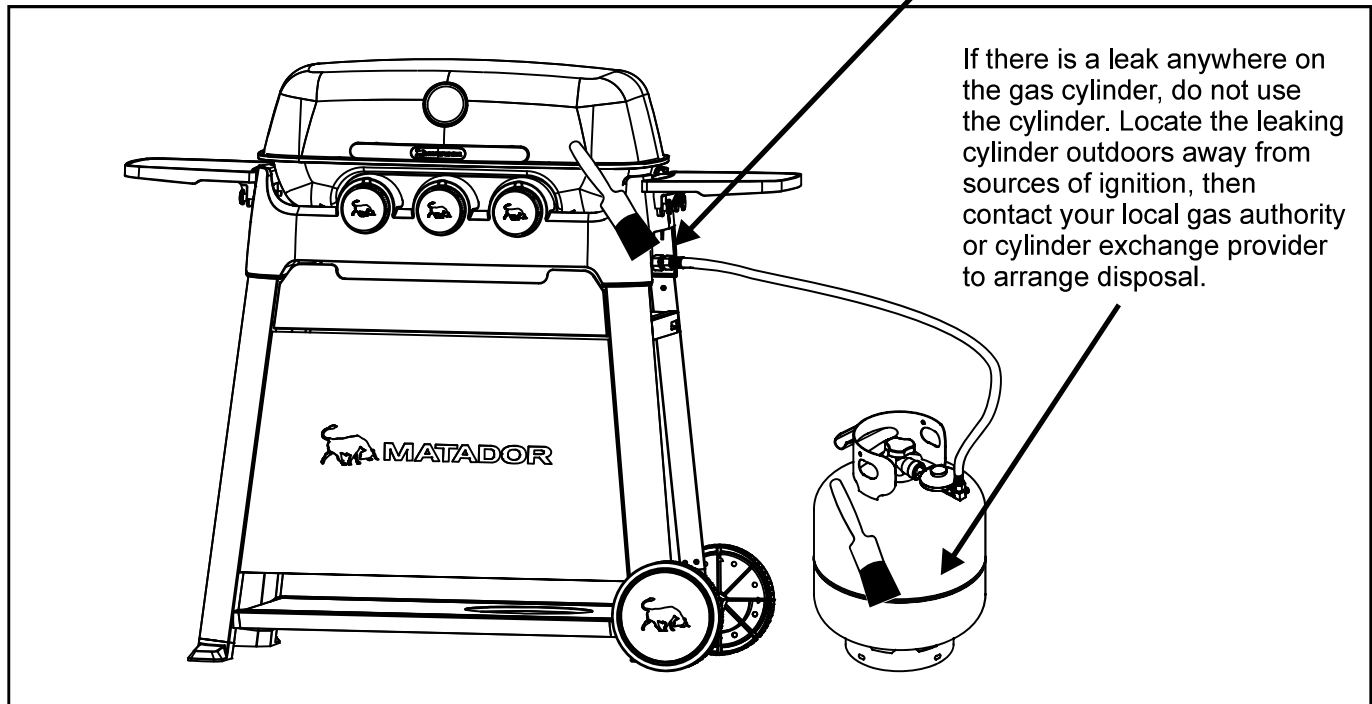

If there is a leak anywhere on the gas cylinder, do not use the cylinder. Locate the leaking cylinder outdoors away from sources of ignition, then contact your local gas authority or cylinder exchange provider to arrange disposal.

IMPORTANT SAFETY INSTRUCTIONS

- 1. This BBQ is an OUTDOOR APPLIANCE ONLY. It should NOT be used indoors.**
2. READ ALL OPERATING INSTRUCTION BEFORE LIGHTING.
3. Do not perform any servicing on the BBQ yourself. This includes internal adjustment of the regulator and gas valves. Servicing can only be carried out by authorised technicians.
4. When cylinder is replaced or reconnected, check for leaks.
5. Do not store chemicals or flammable materials near this appliance.
6. People with flammable clothing such as nylon etc. should keep well away from the BBQ when it is operating.
7. Do not leave food unattended on the BBQ.
8. In case of a fat fire, immediately turn the LPG cylinder valve off.
9. Particular care must be taken when removing drip tray. Hot fat can cause serious injury.
10. This BBQ should not be located under overhead combustible construction and proper clearances must be maintained at all times from combustible construction and/or materials, with **MINIMUM** clearances as follows:
 - From Sides 200 mm
 - From Back 300 mm
 - Overhead 1000 mm
11. Never leave burners on high for more than 10 minutes unless actually cooking. If the burner makes a hissing or roaring sound when lit, it may be burning internally. Turn burner off, allow it to cool and light it again.
12. Do not delay ignition after opening the gas valve, this will result in a buildup of unburned gas.
13. Never use your BBQ in a garage, porch, shed, breezeway or any other enclosed area. Your BBQ should not be placed under any surface that will burn.
14. Do not obstruct the flow of ventilation air around the BBQ.
15. This BBQ is not intended to be installed in or on recreational vehicles and/or boats.
16. Remove promotional stickers (where fitted) from hood before use.



IMPORTANT

This appliance shall only be used in an above ground open-air situation with natural ventilation, without stagnant areas, where gas leakage and products of combustion are rapidly dispersed by wind and natural convection.

WARNING

A strong gas smell or the hissing sound of gas indicates a serious problem with your BBQ or the LPG gas cylinder. Failure to immediately follow the steps listed below could cause serious bodily injury, death, or property damage.

1. Shut off gas supply to the BBQ.
2. Turn the control knobs to OFF position.
3. Put out any flame with a class B fire extinguisher and clear the area of people.
4. Open BBQ hood.
5. Move away from the LPG gas cylinder.

Do not try to fix the problem yourself unless you are competent.







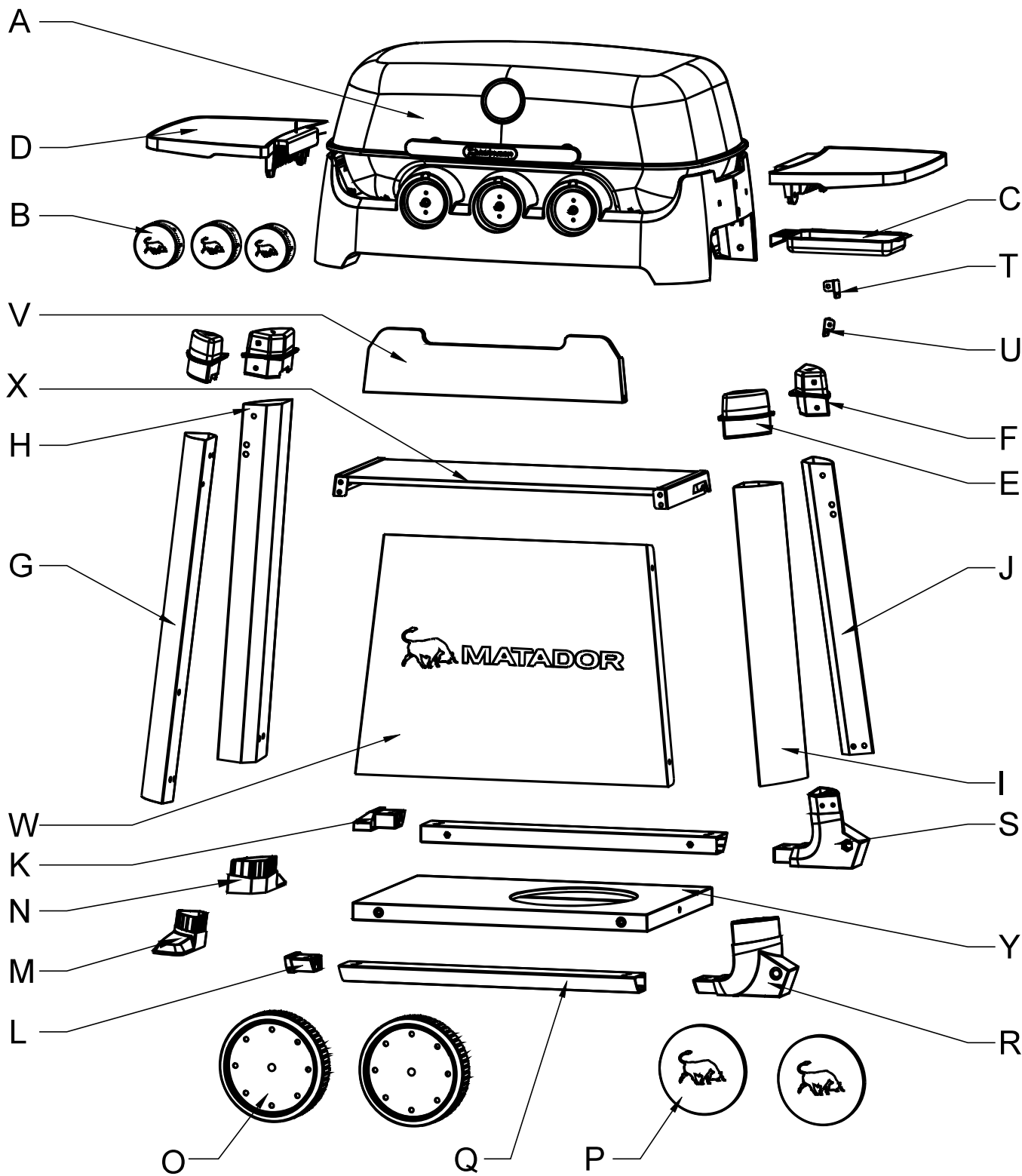

If odour continues or you have a fire you cannot extinguish, call your fire department immediately.

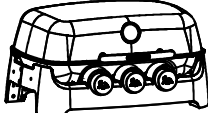

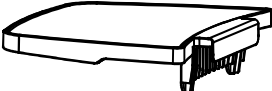
NOTE: The normal flow of gas through the Regulator and Hose Assembly can create a humming sound. A low volume of sound is perfectly normal and will not interfere with operation of the BBQ. If humming sound is loud and excessive you may need to purge air from the gas line.

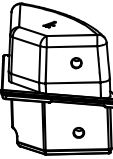
EXPLODED PARTS VIEW





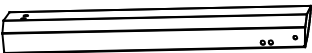
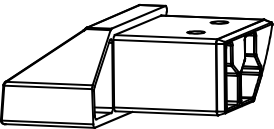
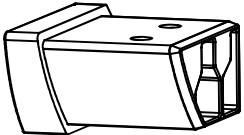
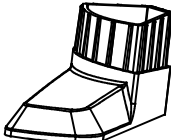
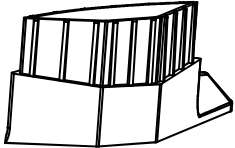
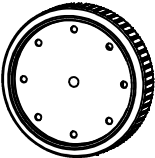



PARTS LIST

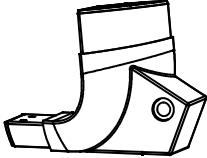
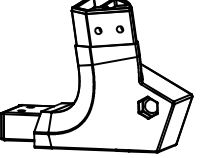

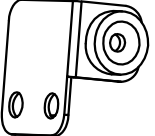
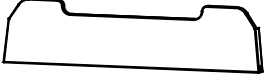
POS	Picture	Part Name	QTY
A		3B BBQ	1
B		Gas knob	3
C		Drip pan	1
D		Side table	2
E		Leg cap E	2
F		Leg cap F	2
G		Leg – left front	1
H		Leg – left rear	1
I		Leg – right front	1

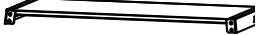
POS	Picture	Part Name	QTY
J		Leg – right rear	1
K		Crossbeam connector A	1
L		Crossbeam connector B	1
M		Foot – left rear	1
N		Foot – left front	1
O		Wheel	2
P		Wheel cover	2
Q		Crossbeam	2

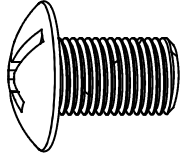
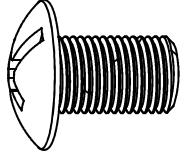
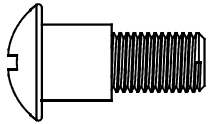
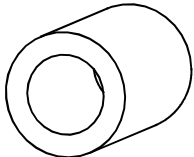
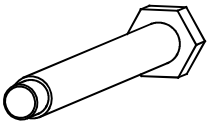

POS	Picture	Part Name	QTY
R		Corner – right front	1
S		Corner – right rear	1
T		Magnet bracket right	1
U		Magnet bracket left	1
V		Flip down tray	1
W		Front panel	1
X		Storage shelf	1
Y		Base	1

BOLT PACK

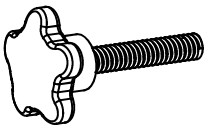
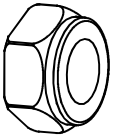
POS	Picture	Part Name	QTY
AA		M6x12 Screw	40
BB		M5x12 Screw	4
CC		M5 Shoulder screw	4
DD		Axle Bush	2
EE		Axle	2
FF		Flip down tray cable	2
GG		Side table fastener	4
HH		M10 Lock nut	2



ASSEMBLY STEPS

Remove all packaging and transit protection materials from parts before assembly.
Wear gloves during assembly to protect your hands from cuts and abrasions.
Some stages of assembly may require a 2 people to complete safely.
To assemble this BBQ you will need a Phillips head screwdriver (not provided with the BBQ).

Step 1.

Assemble the 'Gas knobs' (B) to the BBQ (A).

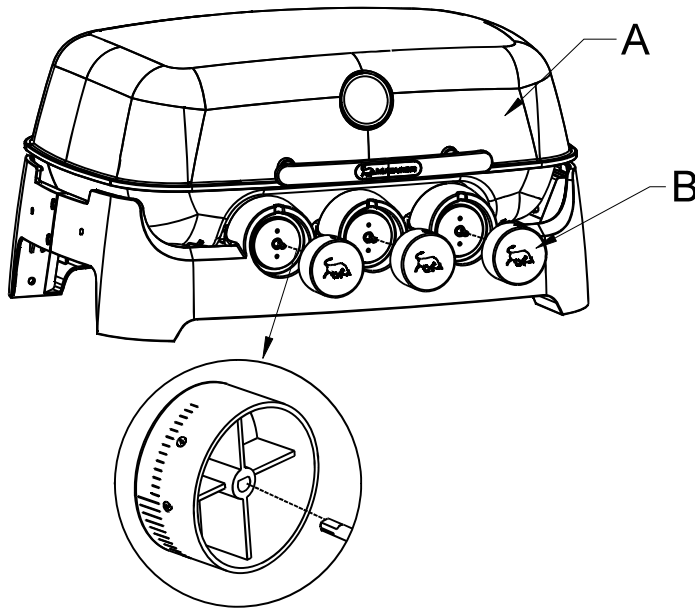

Step 2.

Insert the 'Drip pan' (C) to the BBQ (A).

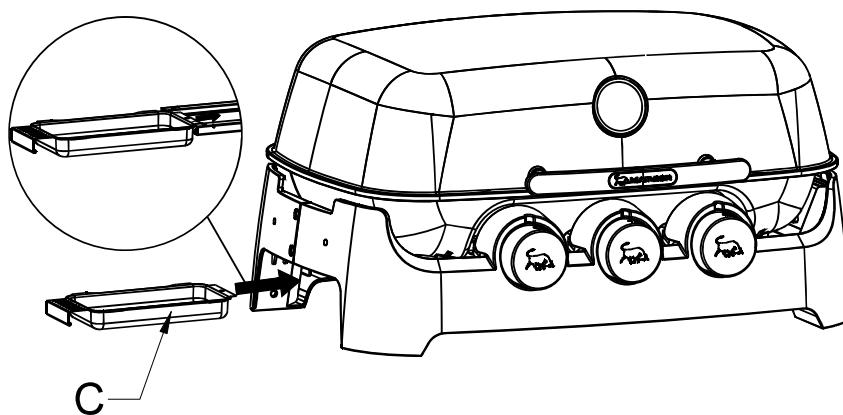

Step 3.

Assemble the 'Feet' (M&N) to the 'Legs' (G&H).

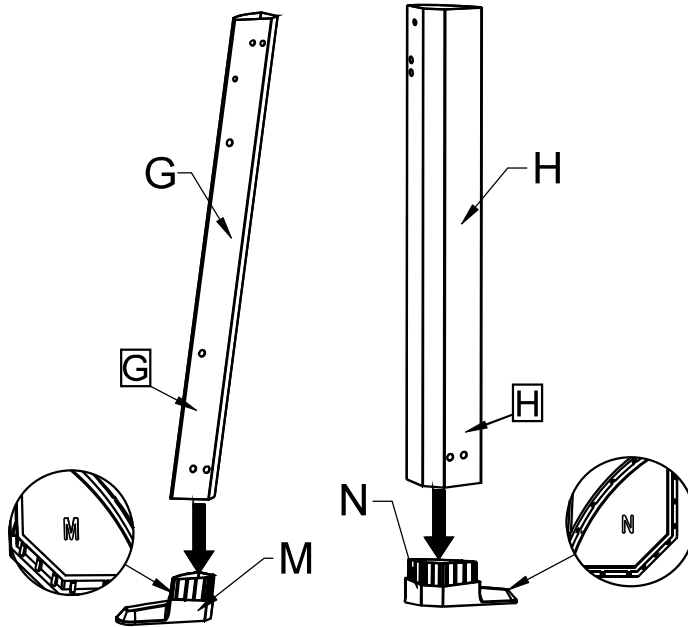

Step 4.

Assemble the 'Crossbeam connectors' (L&K) to the legs (G&H), using Screw (AA) 4pcs.

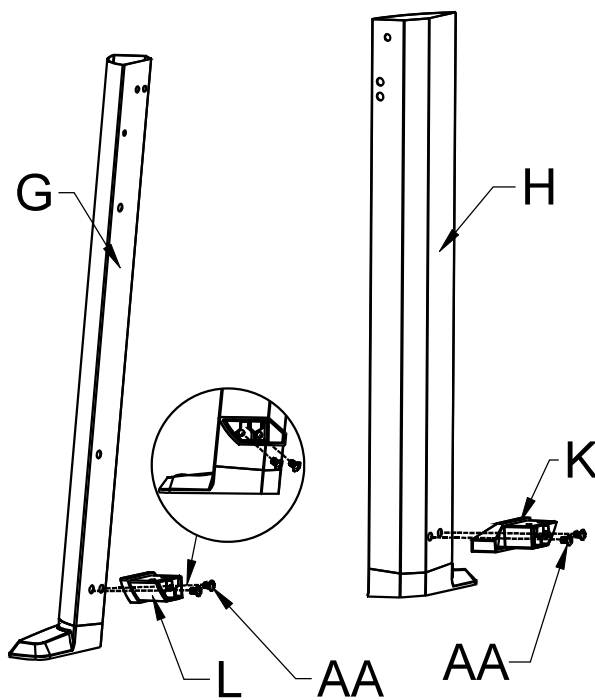

Step 5.

Assemble 'Axle' & 'Axle Bush' (EE&DD) to the 'Wheel' (O), then assemble the wheel assembly to the 'Corners' (R&S), using 'Lock nut' (HH).

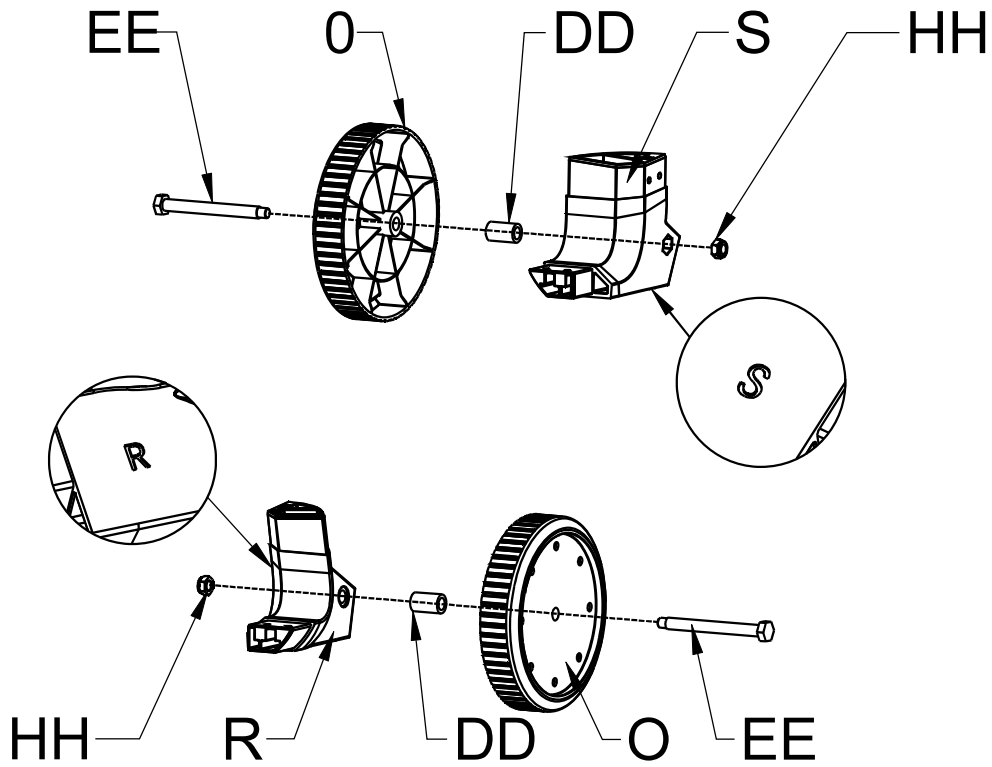

Step 6.

Assemble the 'Wheel cover' (P) to the wheel assembly, using the snap features.

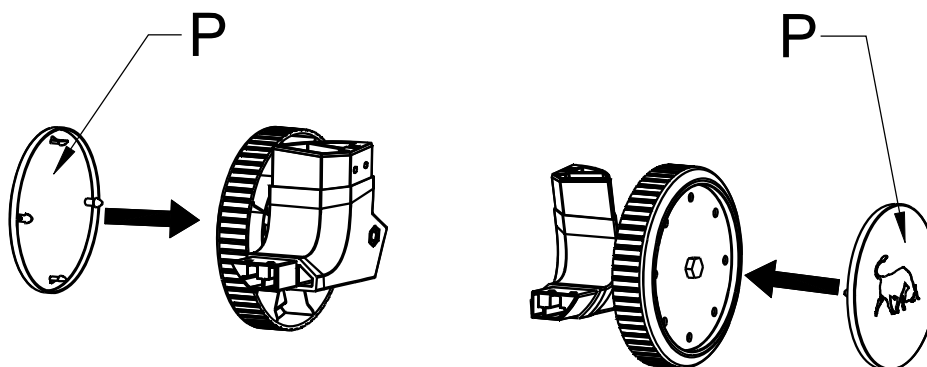

Step 7.

Assemble the 'Crossbeams' (Q) to the 'Base' (Y), using Screw (AA) 4pcs.

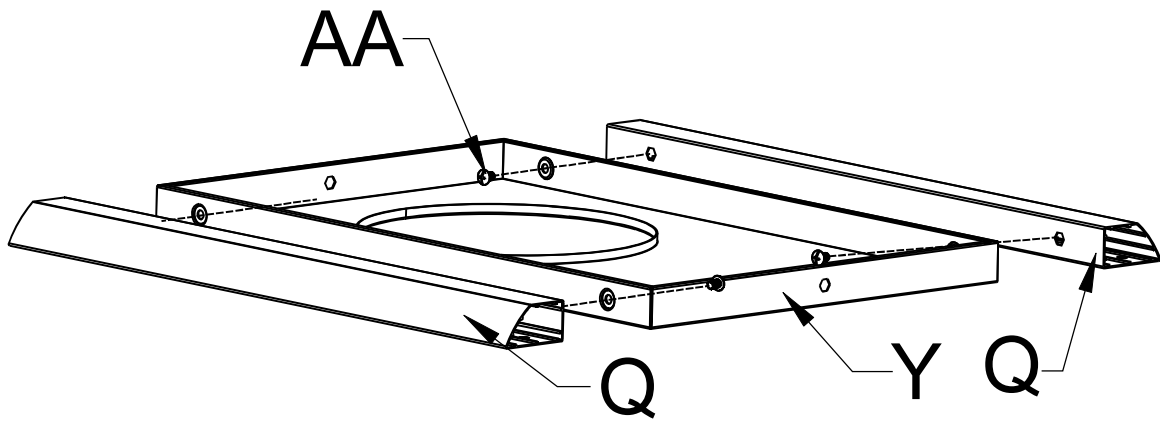

Step 8.

Assemble the Wheel assemblies and Left leg assemblies to the Base assembly, using Screw (AA) 8pcs.

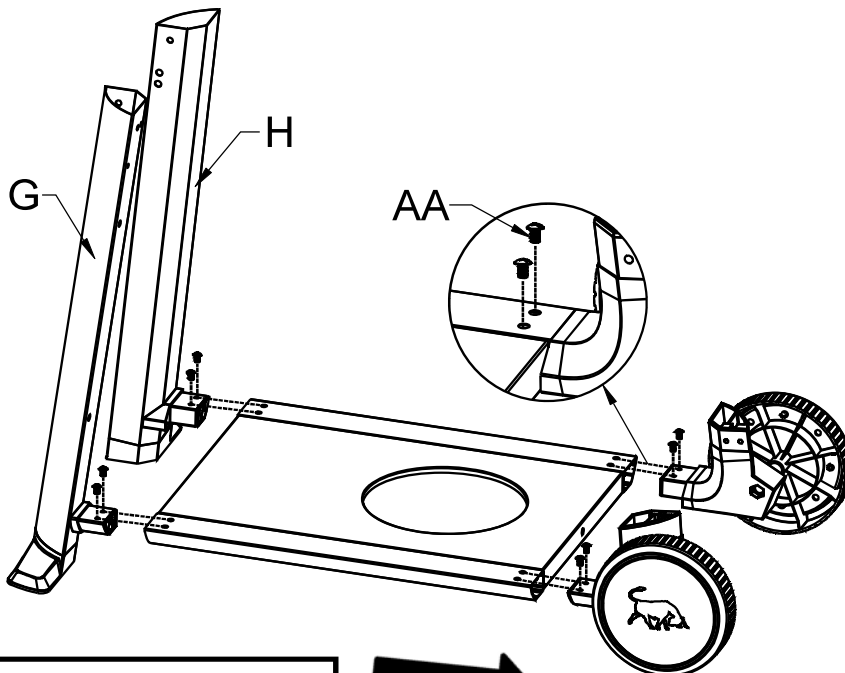

IMPORTANT ORIENTATION



MATADOR

Step 9.

Assemble the Right legs (I&J), using Screw (AA) 4pcs.

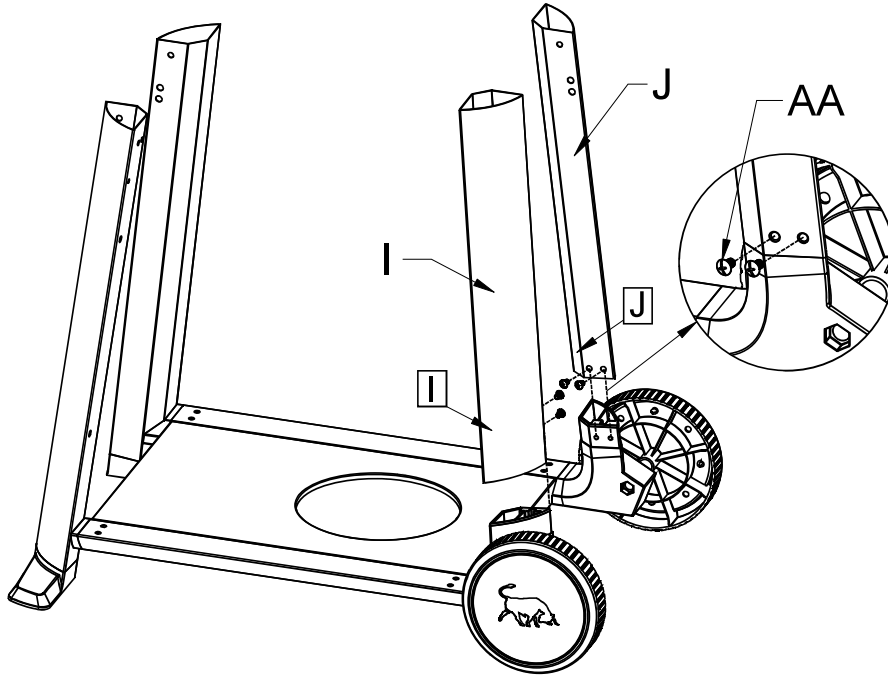

Step 10.

Assemble the 4 'Leg caps' (E&F) to the trolley, using Screw (AA) 4pcs.

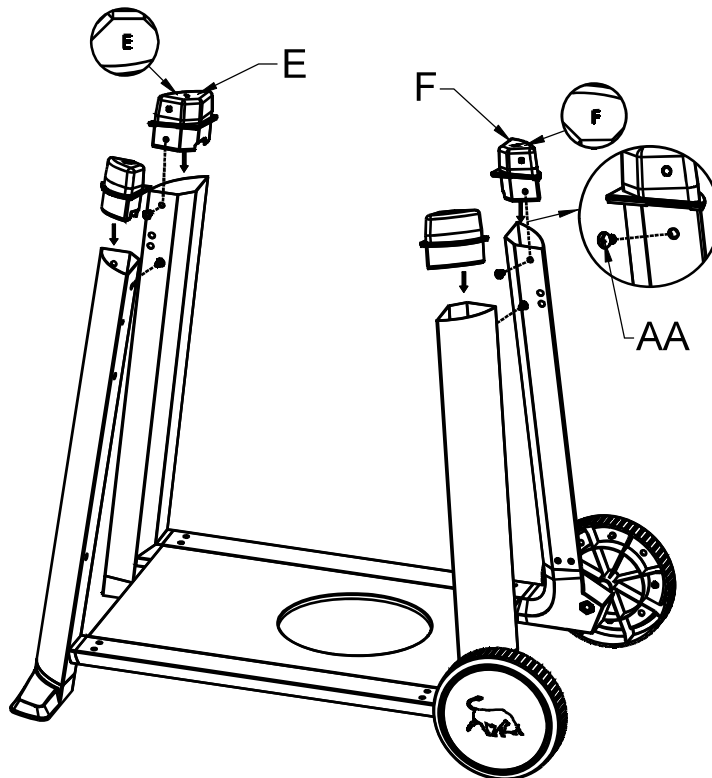

Step 11.

Assemble the 'Storage shelf' (X), using Screw (AA), 8pcs.

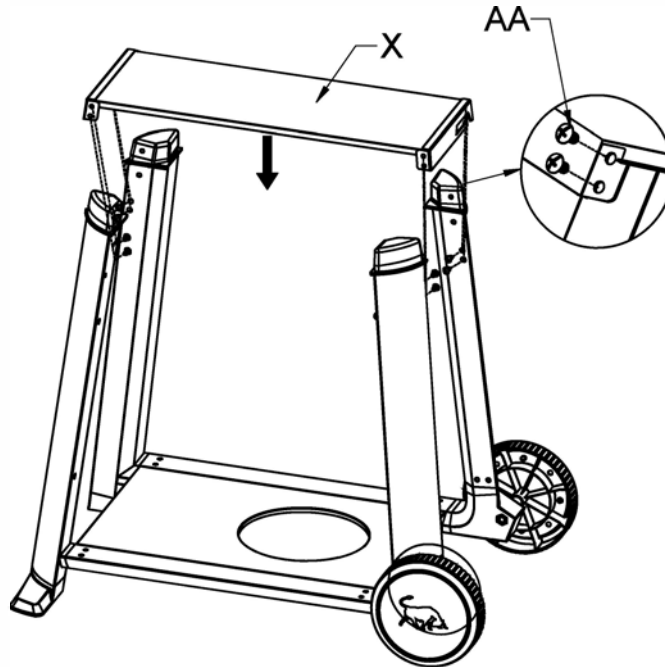

Step 12.

Assemble the 'Magnet brackets' (U&T) to the trolley assembly using Screw (BB) 2pcs in the rear mount hole.

Assemble the end loop of the 'Flip down tray cables' (FF) 2pcs to the 'Magnet brackets' using Screw (CC) 2pcs in the front mount hole.

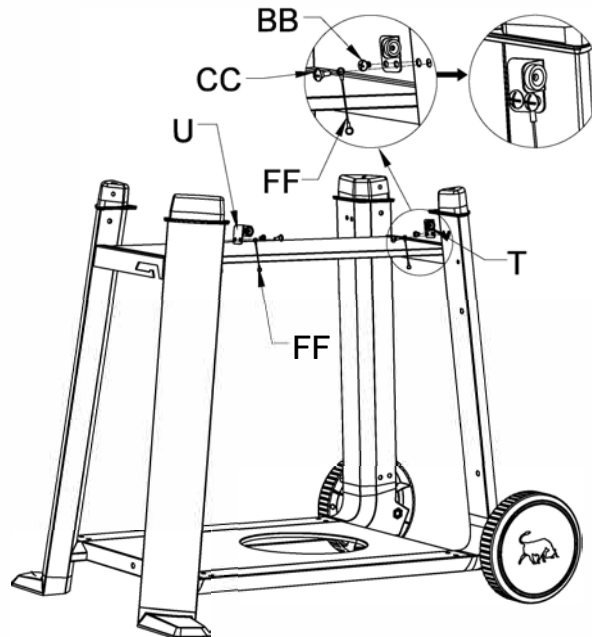

Step 13.

Assemble the 'Flip Down Tray' (V) to the trolley assembly, using the Screw (CC) 2pcs.

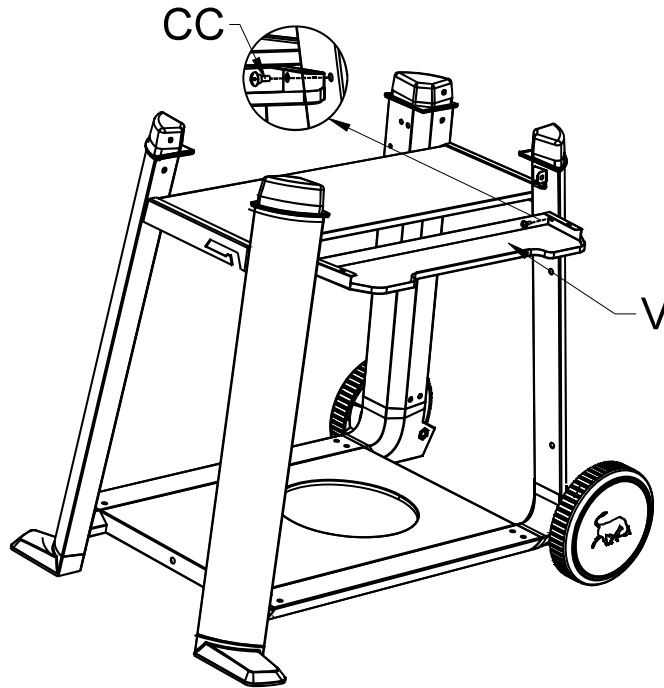

Step 14.

Assemble the chain to the 'Flip down tray' (V), using Screw (BB) 2pcs.

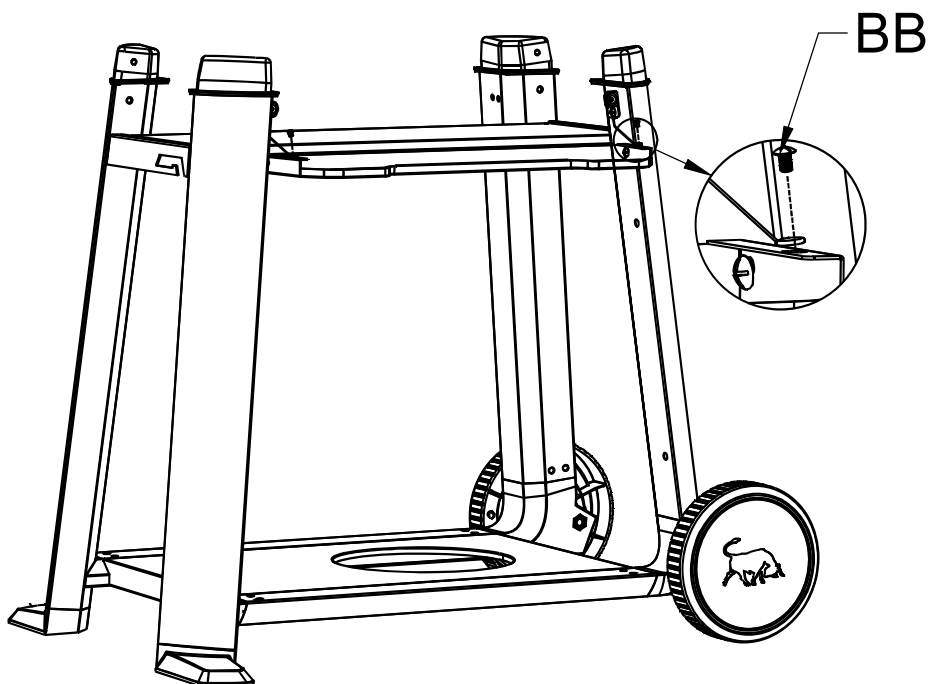

Step 15.

Assemble the 'Front panel' (W) to the trolley, using Screw (AA) 4pcs.

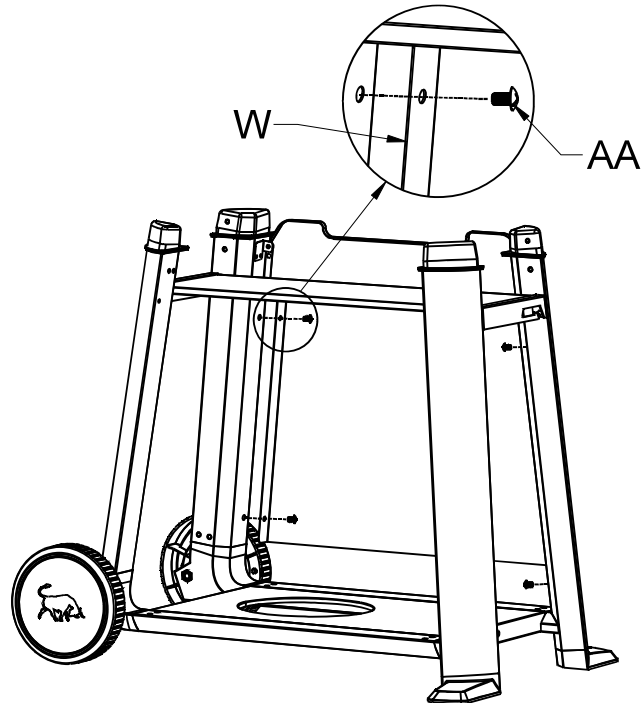

Step 16.

Assemble the BBQ to the trolley, using Screw (AA) 4pcs.

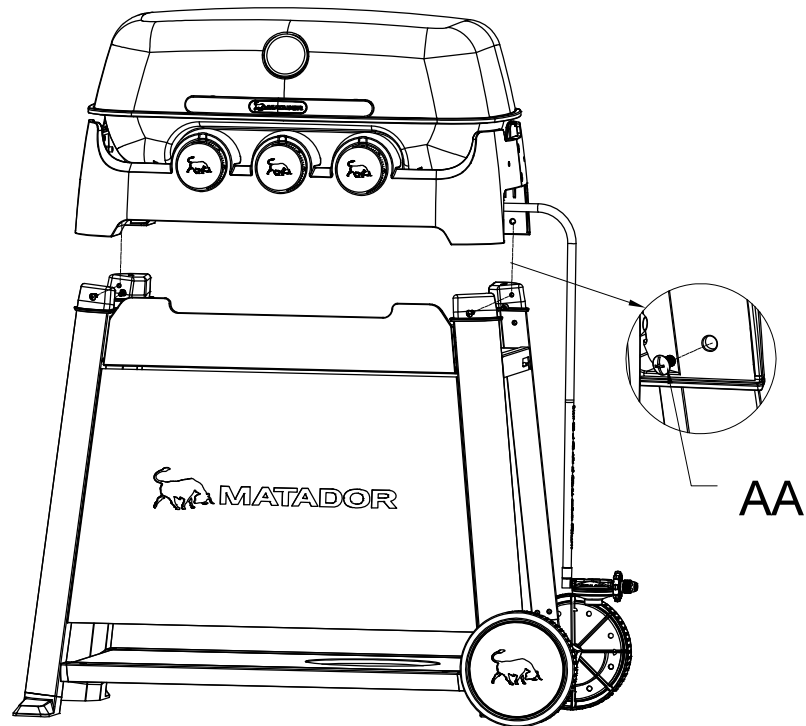

Step 17.

Assemble the 'Side table' (D) to the BBQ, using the 'Side table fastener' (GG) 4pcs.

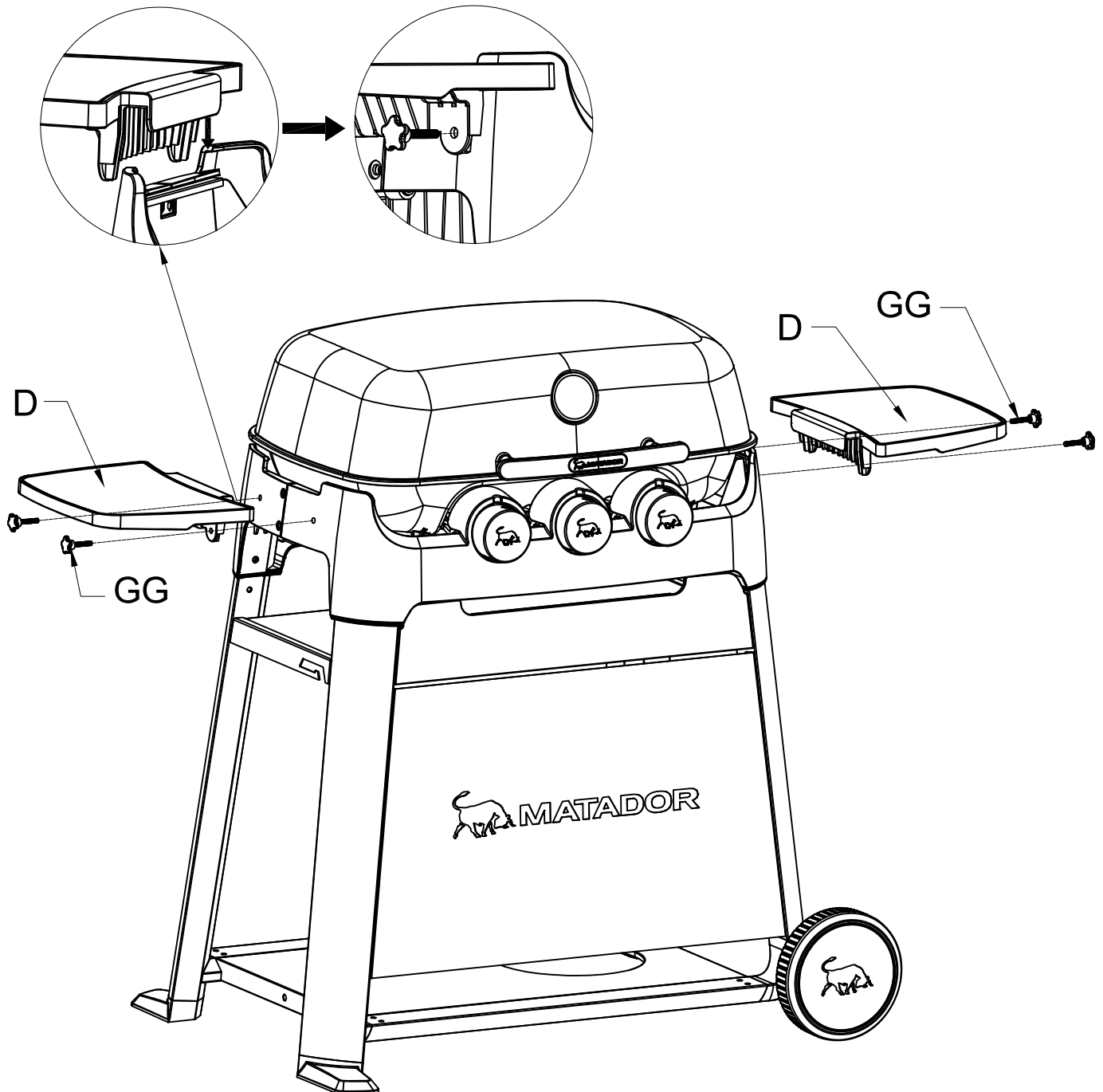

FULLY ASSEMBLED

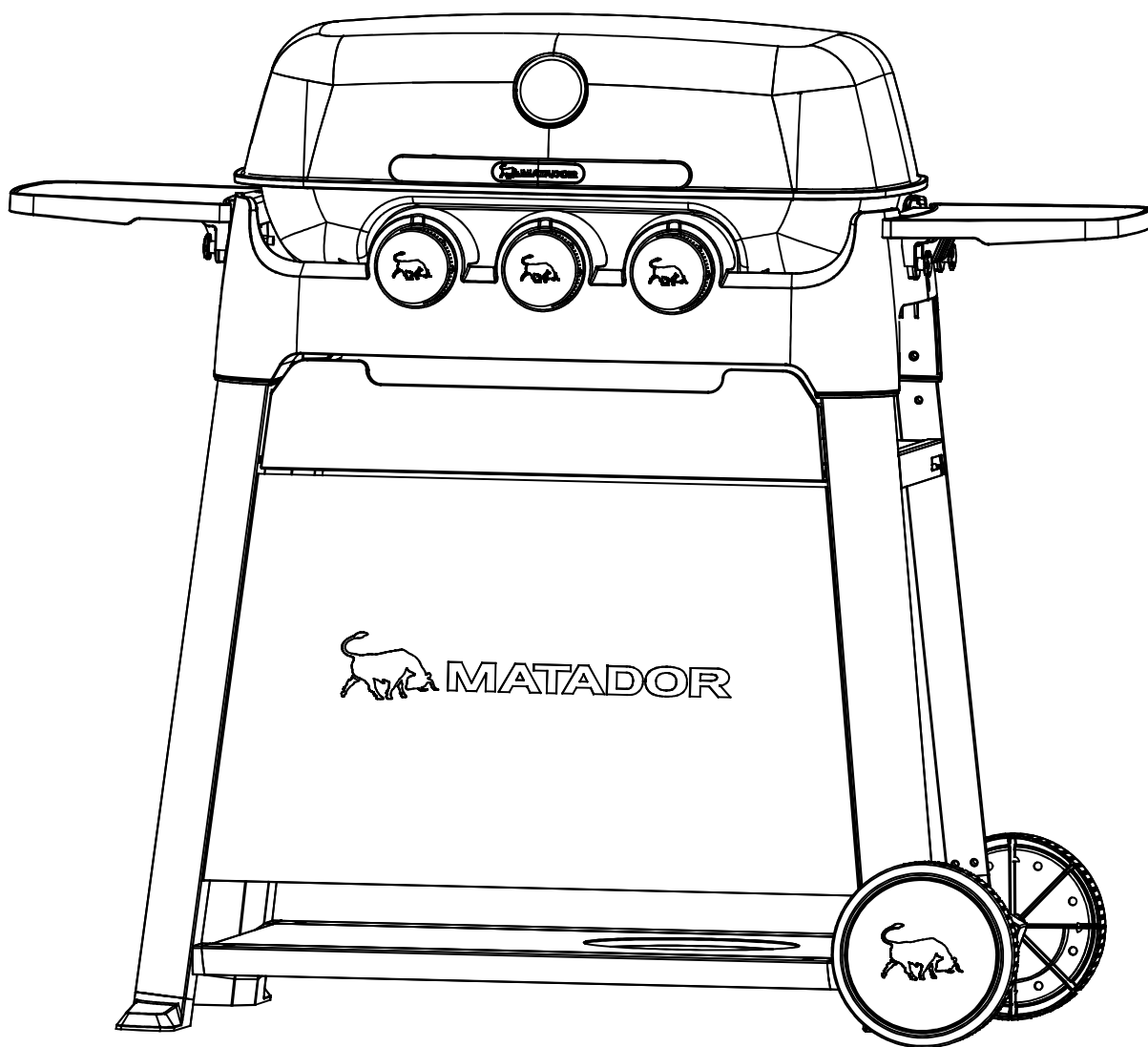

BBQ LOCATION - OUTDOOR AREAS

This appliance shall only be used in an above ground open-air situation with natural ventilation, without stagnant areas, where gas leakage and products of combustion are rapidly dispersed by wind and natural convection.

Any enclosure in which the appliance is installed or used shall comply with one of the following:

An enclosure with walls on all sides, but at least one permanent opening at ground level and no overhead cover.

Within a partial enclosure that includes an overhead cover and no more than two walls.

Within a partial enclosure that includes an overhead cover and more than two walls, the following shall apply:

At least 25% of the total wall area is completely open; and

At least 30% of the remaining wall area is open and unrestricted.

In the case of balconies, at least 20% of the total of the side, back and front wall areas shall be and remain open and unrestricted.

Examples of the correct appliance outdoor setups can be seen below.

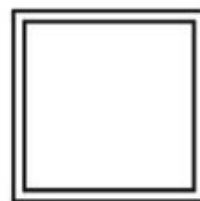
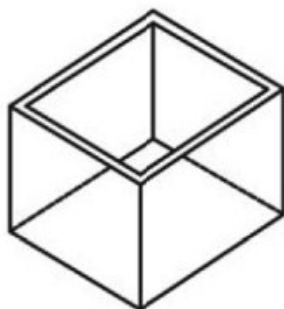

OUTDOOR AREA-EXAMPLE 1

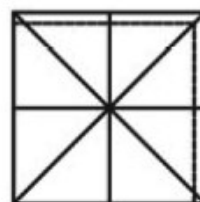
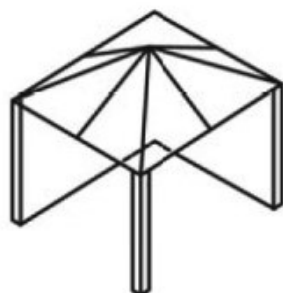

OUTDOOR AREA-EXAMPLE 2

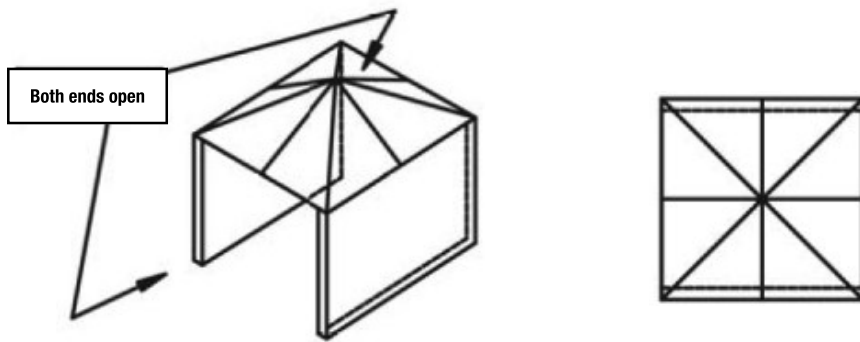

OUTDOOR AREA-EXAMPLE 3

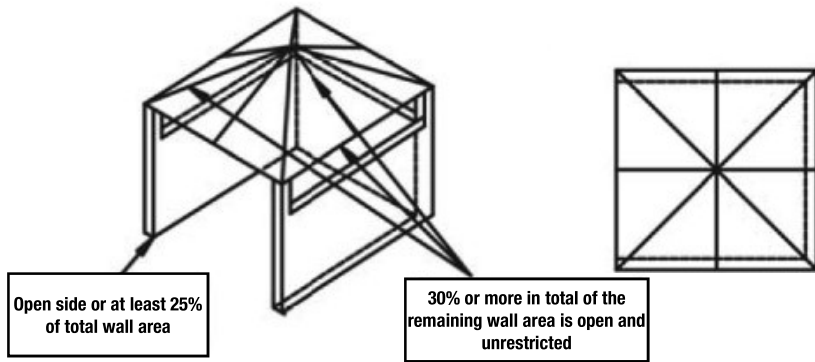

OUTDOOR AREA-EXAMPLE 4

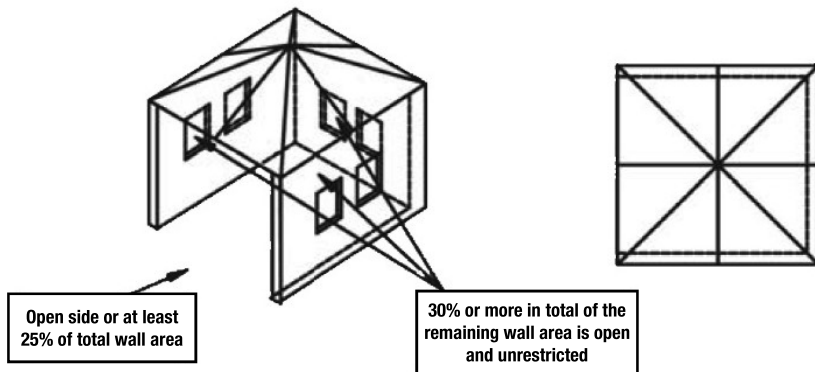

OUTDOOR AREA-EXAMPLE 5



CONNECTION TO LPG CYLINDER

LEAK TESTING

Refer to page 5 of this manual to check for Gas Leak Test.

This should be done the first time you connect up the BBQ, and again each use. Always inspect the hose before each use.

CONNECTING THE LPG CYLINDER

Connect the regulator to the LPG cylinder and tighten the connection.

Turn the gas on at the cylinder, or make sure gas is available to the BBQ, but do not turn the burners on. This fills the gas lines with gas. Now brush or pour some soapy water onto all connections. If there is a leak, bubbles should appear within about 20 seconds. If you find any leaks, tighten the connection and repeat the leak test. If the leaks persist, contact your place of purchase.

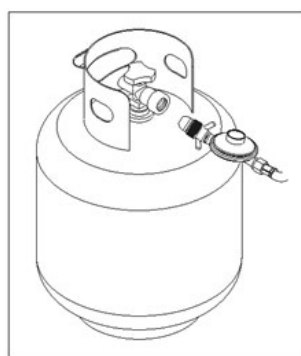

POL

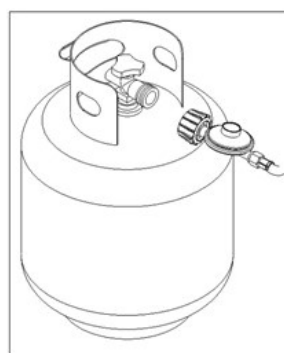

QCC

DO NOT USE NAKED FLAME FOR LOCATING GAS LEAKS

IF A LEAK PERSISTS, CALL AN AUTHORISED PERSON

DO NOT USE THIS BBQ UNLESS ALL CONNECTIONS ARE GASTIGHT

In the case of a problem arising with the hose and regulator please contact your BBQ supplier for a list of approved replacement parts.

LIGHTING PROCEDURE

BEFORE STARTING

- Lighting the BBQ is easy, but must be done with due care.
- Make sure the LPG cylinder contains enough gas.
- Make sure that gas is turned on at the cylinder, or that gas is available to the BBQ.
- Check that the end of each burner tube is properly located over each valve orifice.
- Make sure all gas connections are securely tightened.
- **Open the hood before lighting**

FLAME THROWER IGNITION OF BURNERS

The BBQ burners are equipped with automatic ignition. It works by throwing a flame to the side of the burner to light. Push the knob in and turn anticlockwise to the high position. You should hear and feel a click from the knob. Hold the knob in and observe the flame extend towards the side of the burner. When the burner ignites, release the control knob. If the burner doesn't light on the first attempt, return the knob to the "OFF" position and try again. If the burner still does not light, wait a few minutes to allow the gas to disperse before trying again.

MANUAL IGNITION (in case of lighting failure from BBQ ignition)

With the hood open, place a lit match or long stem gas lighter close to the burner you wish to light. Be cautious of the position of your hand and ensure it remains a reasonable distance from the burner. Turn the control to the "High" position. The burner should light. If it fails to light, return the control to the "OFF" position and try again in five minutes.

CONTROLLING THE FLAMES

The knobs have three basic positions. You can achieve any flame height between low and high by rotating the knob between these positions.

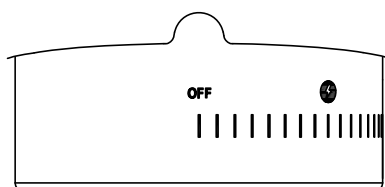

OFF

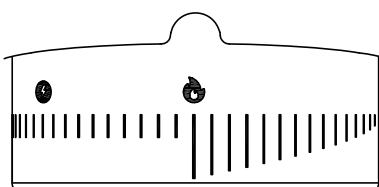

HIGH

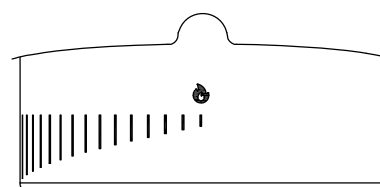

LOW

Note: 'Light back' is a situation where the flame burns inside the burner, towards the front, recognized by a sharp roaring sound coming from the burner. It is not dangerous unless allowed to persist. If this occurs, simply turn the burner off, wait a few minutes, and then relight.



COOKING FOR THE FIRST TIME

Wash all cooking surfaces with a mild soap and warm water solution before use. Strong winds and low temperatures can affect the heating and performance of your BBQ so factor in these elements when positioning your BBQ outdoors for cooking.

BBQ TIPS

- Before cooking, coat the top of the hotplate with oil. This will prevent food from sticking. Light the burners and leave on high for about 3~5minutes to warm the BBQ up.
- Avoid continually turning the meat over. When cooking internal juices rise to the surface of the meat and then settle. Each time you turn the meat over, the juices are lost.
- The minimum size LPG cylinder recommended for this BBQ is 9kg.
- Check the grease tray before use to prevent overflow of grease.
- You may baste the food with light marinade or oil during the cooking process although be careful to avoid flare-ups.
- Avoid burning or charring food.
- Do not leave cooked food standing for too long before eating.

HOW TO PREVENT FLARE UPS AND FAT FIRES

1. If flare ups occur, alternate between cooking on the open grill and solid plate, and reduce the heat under the open grill.
2. Cook with a mix of meats. Fatty chump chops are loaded with flammable fats so be mindful to use appropriate temperatures when cooking foods prone to catch on fire.
3. Monitor the amount of grease dripping into the BBQ because if there is large volume of grease, this may catch alight as a result of a flare up.
4. If you use a fat absorber product in the drip tray, you must change the fat absorber contents in the grease tray well before the fat absorber is overloaded with grease, because fat absorber which is overloaded with grease is flammable.
5. Never allow the BBQ to overheat, always monitor the temperate of your BBQ at all times, even during pre-heating.

AFTER USE

To turn the BBQ off, it is best to turn off the cylinder first, and allow all the gas remaining in the hose to burn off, this will only take a couple of seconds. Then turn off all burners.

While the hotplate is still hot, take a long-handled brush and a scraper and remove remaining oil and food scraps. You should use protective gloves to avoid burning yourself. Then recoat the plate with oil for continued protection. Clean the residual oil off the plate immediately before the next cook up.

CLEANING AND MAINTENANCE

Remember to turn off and disconnect the gas before any maintenance is carried out.

Your BBQ will look better and last longer if you keep it clean.

You should check the burners periodically as explained in the section 'Burner maintenance'.

You should empty the fat / drip tray frequently. Never touch the fat / drip tray until the BBQ and fat have cooled down completely.

Regularly maintain the external surfaces of your BBQ by cleaning with warm water and a light detergent.

Regularly remove grease from the firebox before there is a heavy build up. Don't use a steam cleaner or harsh chemicals such as oven cleaner. If the BBQ requires a stronger cleaning agent, use a mild dishwashing soap, hot water and a soft cloth, rinse and dry thoroughly.

Salt Water and corrosive atmospheres can rapidly degrade and permanently damage your BBQ. In this type of harsh environment, your BBQ will require more regular cleaning.

UV rays produced by sunlight can rapidly degrade your BBQ. Where possible, protect the BBQ from the harsh elements. We recommend the use of a BBQ weather cover to protect your BBQ from the elements.

ABNORMAL OPERATION

Abnormal operation which may require service can be identified by the following:

1. A yellow burner flame
2. A thick, black build-up of soot.
3. Control valves that seize or are difficult to turn.
4. Burners which are difficult to light.

If the BBQ fails to operate correctly, contact an authorised service person for repair.

ACCESSORIES

If you would like to purchase any of the following accessories, please contact Pacific Gas & Heating Pty Ltd by phone on 1300 793978 or email service@pacifictrends.com.au

Accessories available for BG323-3B on Trolley:

- BBQ weather cover to protect your BBQ from the elements.



CONVERSION TO TABLE TOP / PORTABLE BBQ

Simply unscrew the side shelf fasteners and remove the side shelves by lifting them up.

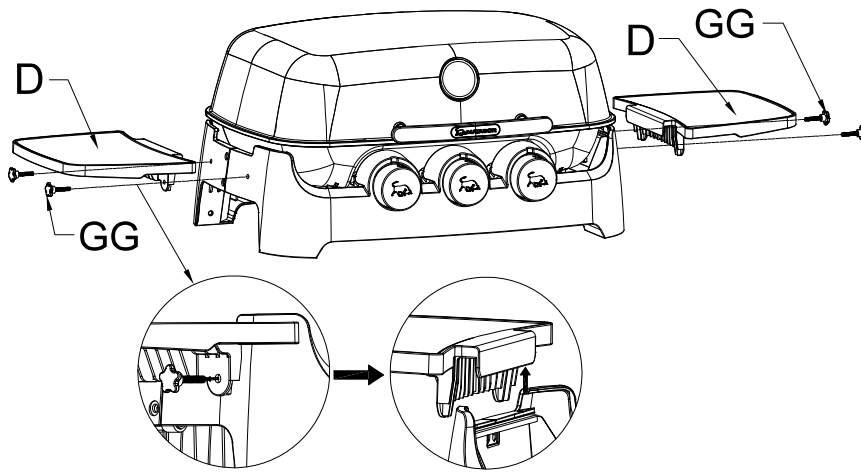

Then remove the 4 screws shown below and lift the BBQ off the trolley.

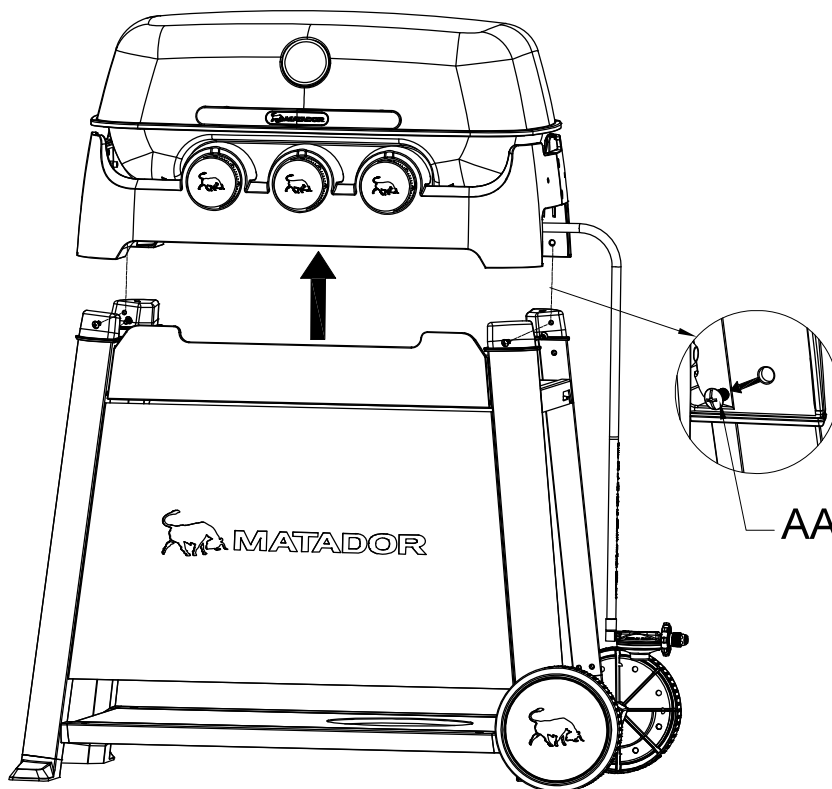

For table top / portable use, locate the **LPG cylinder as far away from the BBQ** as possible and ensure the hose is not exposed to heat from the grill or hood vent.

When transporting the BBQ, ensure the grease cup is empty to prevent spills and if you're planning an off road adventure, remove the cooking plates from the firebox and store them securely to prevent transit damage.

TRANSPORTATION

Use two hands when moving.

Ensure correct hand position as indicated below when wheeling around. Incorrect hand position may lead to failure of the side table.

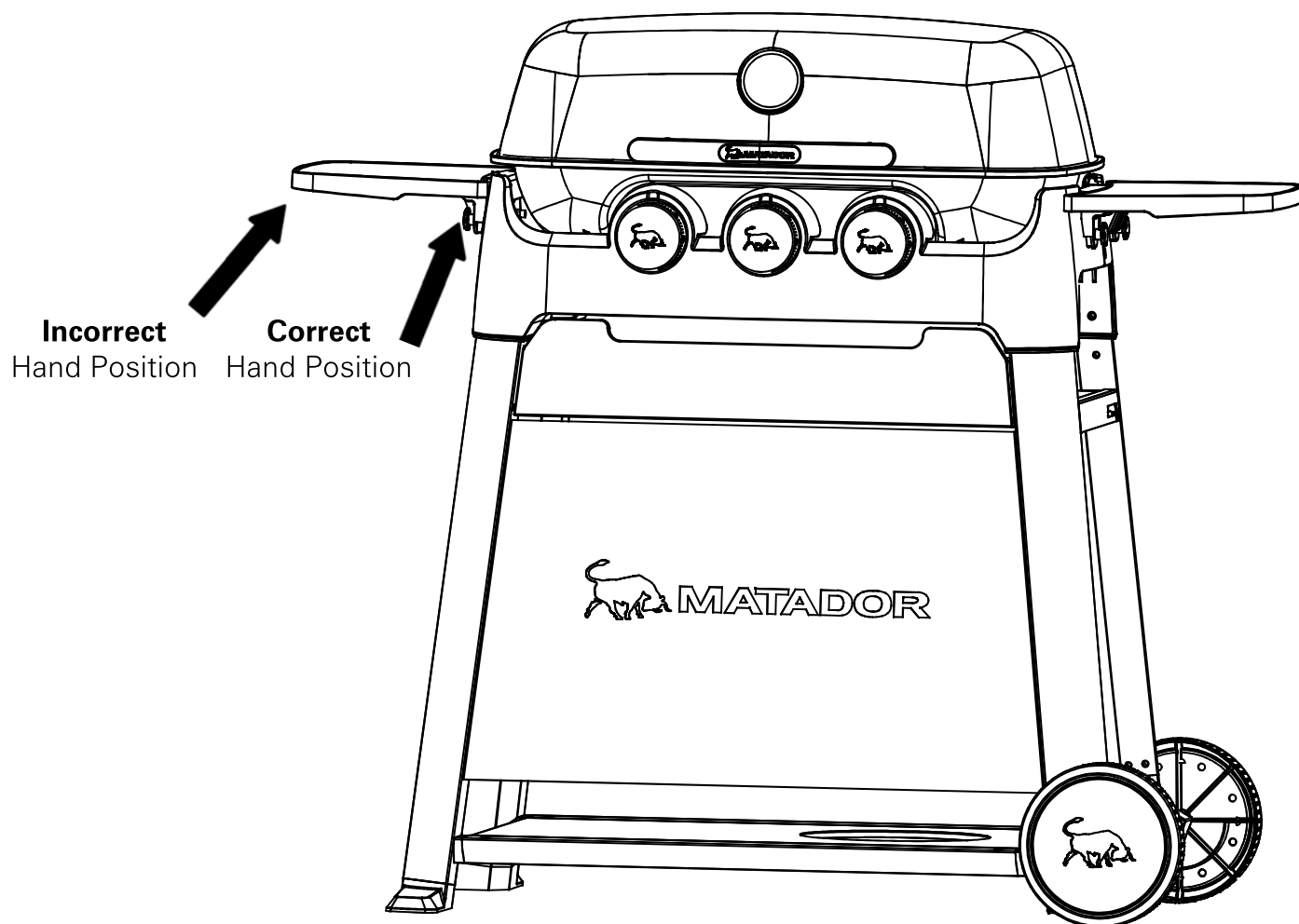

BURNER MAINTENANCE

To reduce the chance of lighting back of the burner, the procedure below should be followed at least once a year, seasonally when spiders are most active or when your BBQ has not been used for a period of time.

1. Turn all burners' valves to the full OFF position.
2. Turn the LPG cylinder valve (clockwise) to the full OFF position.
3. Detach the regulator assembly from the LPG cylinder.
4. Remove the grill and hotplate.
5. Remove the burner or burners with a Phillips head screw driver.
6. Carefully lift each burner up and away from the gas valve orifice.



7. Refer to figure below and perform one of these three cleaning methods.

Bend a stiff wire, (a lightweight coat hanger works well) into a small hook as shown below. Run the hook through the burner tube and inside the burner several times to remove any debris.

Use a bottle brush with a flexible handle or a pipe cleaner to run through the front section of the burner tube and clean any spider webs or debris from inside the burner.

Use an air hose to force air through each burner tube. The forced air should pass debris or obstructions through the burner and out the ports.

Use a wire brush to clean the outer surface of each burner until free of debris and residue. Clean clogged ports with a pipe cleaner or an open paper clip.

Inspect each burner after installation, check to ensure that the gas valve orifices are correctly placed inside the end of the burner tubes.



After cleaning, install the burner/s in the reverse order of the removal steps and ensure the burner inlet is located over the valve orifice.

STORAGE

1. Ensure the BBQ is properly cooled.
2. Storage of this gas BBQ indoors is permissible only if the gas cylinder is disconnected and removed from the BBQ.
3. Store the BBQ in a cool dry place.
4. Always disconnect the gas cylinder and store it in a safe place, never store a gas cylinder on its side.
5. Never store a gas cylinder in a building, garage or any other enclosed area.
6. If you intend to leave your BBQ outside make sure it is protected from the elements by a heavy-duty cover (not included).



WARNING
STORE CYLINDER IN A WELL-VENTILATED
AREA
OUT OF REACH OF CHILDREN

IMPORTANT

- This product is for outdoor use only. Do not use indoors. Do not use below ground level.
- Do not store gas cylinders below ground level. LP gas is heavier than air so if a leak occurs the gas will collect at a low level and could ignite in the presence of a flame or spark.
- Do not store or use LP gas cylinders on their side as this could allow liquid gas into the supply lines with potential serious problems.
- Leak test your BBQ before each use. Leak test the hose connections each time you reconnect the gas cylinder.
- Always turn off the gas at the cylinder when not in use.
- Inspect the hose before each use. If there is evidence of excessive abrasion or wear, or the hose is cut it must be replaced prior to the outdoor gas BBQ being put into operation. Only use hose supplied from the manufacturer.

You must have the correct gas cylinder, regulator and hose for this BBQ to operate safely and efficiently. Use of an incorrect gas cylinder, regulator or hose is dangerous and will void the warranty on this product.

CARE AND MAINTENANCE

Remember to turn off and disconnect the gas before any maintenance is carried out.

1. If your BBQ uses a flexible hose to connect to the gas cylinder, check the rubber O-ring on the regulator end of the hose assembly at least once a year. If it appears worn or cracked, have it replaced.
2. We recommend having your BBQ checked by an authorised service agent every 5 years. This is to ensure there are no leaks and that all components are still functioning correctly.
3. Keep the outdoor gas BBQ area clear and free from combustible materials, gasoline, and other flammable vapors or liquids.
4. Make sure there is no obstruction surrounding the BBQ, which may block the flow of combustion and ventilation air.
5. To maintain the surface of your hotplate and grill plate, it is recommended to periodically wash cooking surfaces with a mild soap and warm water solution. Afterwards keep the hotplate and grill plate oiled and covered with the hood when not in use. A BBQ cover (not included) is also recommended to cover your BBQ and maintain and protect from all weather conditions.

CONNECTION TO NATURAL GAS

This BBQ has been configured for use with LPG from a gas cylinder. If you want to connect this BBQ to a permanent Natural Gas supply, the following steps must be undertaken.

1. Contact a licensed plumber or gas fitter and arrange a quote to convert this BBQ to Natural Gas and supply any pipework necessary to bring a natural gas supply line to the BBQ installation area. All works must be made in accordance with AS5601.1.
2. Contact Pacific Gas & Heating Pty Ltd directly on Tel: 1300 793978 or email service@pacifictrends.com.au to order your gas conversion kit
3. Obtain a certificate of compliance from your licensed gas fitter

Natural Gas Conversion Procedure

Gas conversion must be conducted by a licensed plumber or gas fitter only.

1. Install a gas isolation valve at the gas supply point.
2. Remove the LPG hose and regulator.
3. Remove BBQ Burners and close the aeration shutters.
4. Remove the control knobs to access the valve mounting screws.
5. Unscrew the valve mounting screws, then remove the 4 screws securing the BBQ firebox to the trolley stand.



6. Lift the BBQ firebox and remove the gas manifold assembly.
7. Replace the LPG valves with Natural Gas valves.
8. Install Natural Gas injectors stated on the data label then leak test the manifold assembly.
9. Install the manifold and the BBQ firebox onto the trolley stand, install the knobs and the burners.
10. Fit the 10mm ID Natural gas hose, brass adaptor and ½" BSP, Natural gas regulator to the manifold.
11. Leak test all connections.
12. Set the pressure to 1.0kPa with all burners on high.
13. Test the operation of all burners on high and low to complete the commissioning process. The burners must light reliably. If necessary, use a small screw driver to slightly adjust the direction of the flame thrower.
14. Fix the BBQ to the floor with the ground fixing bracket to prevent strain on the hose and gas connections.
15. Instruct the consumer on correct use of the BBQ and the location of the supply isolation valve which shall be closed after each use.

SPECIFICATION

REGULATOR & HOSE ASSEMBLY

(Supplied with BBQ): 2.75kPa, POL type regulator and 8mm ID, Class A hose with 3/8SAE Female outlet. AGA approved.

Burner Configuration Table - Universal LPG

BURNERS	NOMINAL GAS CONSUMPTION	TEST POINT PRESSURE	INJECTOR SIZE
LH	9.5 MJ/h	ULPG @ 2.75 kPa	0.85mm
Middle	8.0MJ/h	ULPG @ 2.75 kPa	0.77mm
RH	9.5MJ/h	ULPG @ 2.75 kPa	0.85mm

Burner Configuration Table – Natural Gas

BURNERS	NOMINAL GAS CONSUMPTION	TEST POINT PRESSURE	INJECTOR SIZE
LH	9.5 MJ/h	Natural gas @ 1.0 kPa	1.35mm
Middle	8.0MJ/h	Natural gas @ 1.0 kPa	1.25mm
RH	9.5 MJ/h	Natural gas @ 1.0 kPa	1.35mm

PRODUCT WARRANTY

Thank you for purchasing one of our quality MATADOR products. Your MATADOR product is covered against defects for a period of 5 years for parts and labour, repair or replacement. This warranty excludes surface rust and damage caused by abuse or neglect.

This warranty in **Australia** is given by Pacific Gas & Heating Pty Ltd,
Tel: 1300 793978
Email: service@pacifictrends.com.au

The warranty in **New Zealand** is given by Bunnings NZ Ltd, PO BOX 14436, Panmure, Auckland, 1741.
Tel: 1800 797 586 Fax: 09-9782222
Email: onlineEnquiries@bunnings.co.nz

Any claim under this warranty must be made within 5 years of the date of purchase of the product. Proof of purchase must be presented.

Goods presented for repair may be replaced by refurbished goods of the same type rather than being repaired. Refurbished parts may be used to repair the goods.

FOR AUSTRALIAN CUSTOMERS

To make a claim under the warranty please contact the store where the product was purchased or contact Pacific Gas & Heating Pty Ltd directly.

CONDITIONS OF THE WARRANTY

The warranty covers domestic use only and does not apply to commercial applications. You may submit details and proof to our store for consideration.

The warranty covers manufacture defects in materials, workmanship and finish under normal use. This warranty is provided in addition to other rights and remedies you

may have under law: our goods come with guarantees which cannot be excluded under the Australian Consumer Law. You are entitled to replacement or refund for a major failure and to compensation for other reasonably foreseeable loss or damage. You are also entitled to have the goods repaired or replaced if the goods fail to be acceptable quality and the failure does not amount to a major failure.

FOR NEW ZEALAND CUSTOMERS

To make a claim under the warranty, take the product (with proof of purchase) to any Bunnings store (See www.bunnings.co.nz for store locations). This warranty is provided in addition to other rights and remedies you may have under law: our goods come with guarantees which cannot be excluded under the Consumer Guarantees Act 1993(NZ). You are entitled to replacement or refund for a major failure and to compensation for other reasonably foreseeable loss or damage. You are also entitled to have the goods repaired or replaced if the goods fail to be of acceptable quality and the failure does not amount to a major failure.

Goods presented for repair may be replaced by refurbished goods of the same type rather than being repaired. Refurbished parts may be used to repair the goods.

The warranty excludes damage resulting from product misuse or product neglect.

The warranty covers domestic use only and does not apply to commercial applications.



PRODUCT WARRANTY

Please thoroughly read conditions of warranty

- The appliance must be operated and maintained in accordance with the instructions supplied in the operating manual.
- Any repair does not extend the warranty period.
- Any parts other than original Matador
- parts will void this warranty.

INSTALLATION CONDITIONS

All installations must conform to the applicable Electrical and Building standards as laid down by the local codes or state or region.

WHAT IS NOT COVERED IN THE WARRANTY

- Removal or re-installation costs. This warranty does not cover costs for transit nor in home service.
- Lack of maintenance, abuse, neglect, misuse, accidental or improper installation of this appliance.
- Scratches, dents, corrosion or discolouration caused by heat, abrasive chemical cleaners or chipping.
- Corrosion or damage caused by exposure to the elements such as insects, weather or hail.
- Cleaning and wear and tear; service calls of this nature are chargeable. Commercial use of the product.
- Unauthorised repairs or modifications during the warranty period.
- Consumable items, example – heating elements.

RECORD THE FOLLOWING INFORMATION

Attach a copy of the purchase receipt here:

Date of purchase

Purchase from

Location

Model no. & name

Date of manufacture

Receipt number

FOR TECHNICAL ASSISTANCE

FOR AUSTRALIAN CUSTOMERS

If you experience any technical issues with your MATADOR product, in the first instance review the instruction manual or call the warranty service agent below.

FOR NEW ZEALAND CUSTOMERS

If you experience any technical issues with your MATADOR product, in the first instance review the instruction manual or call your local Bunnings Warehouse.

WARRANTY CLAIMS

FOR AUSTRALIAN CUSTOMERS

Please contact Pacific Gas & Heating Pty Ltd,
Tel: 1300 793978.
Email: service@pacifictrends.com.au

FOR NEW ZEALAND CUSTOMERS

Please contact the store where the product was purchased.



Visit www.matadorbbqs.com.au

For technical and warranty support call
1300 793 978 (AUS)
1800 797 586 (NZ)

Your purchase receipt will be required for warranty claims.
For spare parts contact Pacific Gas & Heating Pty Ltd.