



MIMOSA®

Cordoba White Coffee Table  
Installation Guide

The first part of the document discusses the importance of maintaining accurate records of all transactions. It emphasizes that every sale, purchase, and payment must be properly documented to ensure the integrity of the financial statements. This includes keeping receipts, invoices, and bank statements in a secure and organized manner.

Next, the document outlines the process of reconciling the company's books with the bank statements. This involves comparing the company's records of deposits and withdrawals with the actual bank activity. Any discrepancies should be investigated and resolved promptly to avoid errors in the financial reporting.

The document also addresses the issue of depreciation and amortization. It explains how these non-cash expenses are calculated and recorded, and how they affect the company's net income and asset values over time. Properly accounting for these expenses is crucial for providing a true and fair view of the company's financial performance.

Finally, the document concludes with a summary of the key points discussed and a reminder of the importance of regular financial reviews and audits. It encourages the company to maintain a high level of transparency and accountability in all financial matters.

# Cordoba White Coffee Table

**POWDER COATED ALUMINIUM FRAME**

**5mm Stone Look Tempered Glass Table Top**

**ITEM NO. : 0583700**

4.

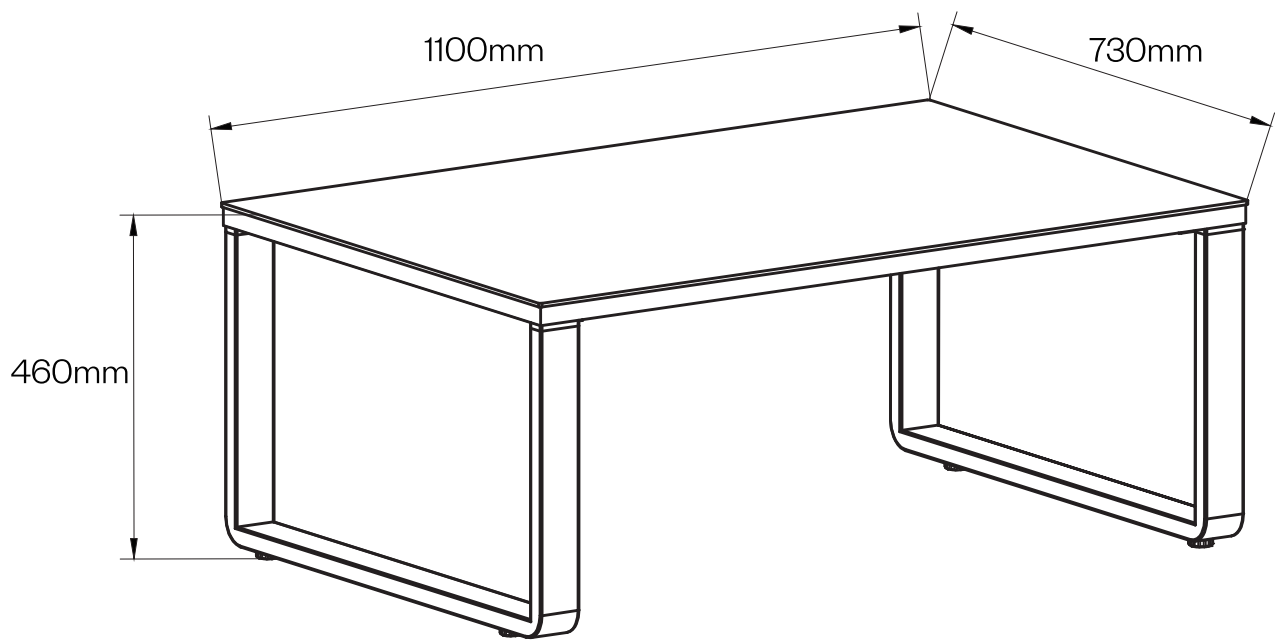



**Please carefully read the below warnings and instructions.  
Save the instructions for future reference.**



- Please carefully read all instructions before assembly and use.
- Please separate and identify all parts, ensuring that you have all parts listed.
- Assembly to be carried out by a competent adult.
- During assembly children should be kept away from the product due to possible risk of injury, small parts, and sharp fittings.
- Do NOT use power tools to assemble the product.
- Don't tight all the bolts before the product is fully assembled. Be careful not to over tighten the nuts during assembly.
- Please check the fixings are all tight monthly.

**Recommendation**

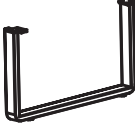

- It would be useful to ask someone to help you assemble the product.
- Retain these instructions for future reference.
- This product is not suitable for extreme weather conditions. Do NOT use in extreme weather condition such as thunderstorm, hailstone, heavy rain, high wind or heavy snow, etc. Warranty claims due to weather events won't be taken into account.
- This piece of furniture has been produced under the best possible conditions and care. However we advise you during constructing or breaking down of this piece of furniture to be aware of sharp metal.
- This product is designed for occasional use only. Do not use as a permanent structure. If no use for long time, dismantle and store safely to prevent any damage occurring.
- If the glass is chipped or broken, stop using the product and consult the manufacturer or supplier.
- Do not place very hot or very cold items on the glass surface(s) unless adequately thick table mats are used to prevent such items from coming into contact with the glass.
- Do not use the glass as a chopping surface. Do not strike the glass with hard or pointed items.
- When cleaning glass panels use a damp cloth or leather with washing up liquid or soft soap if necessary; do not use washing powders or any other substances containing abrasives since these substances scratch glass.
- When using a plastic cover on your furniture, you will need to put an extra cotton medium between this cover and the glass surface. Direct contact between some plastics and the surface of the glass may lead to permanent damage of the table under moist and hot conditions.
- Do not sit or stand upon the glass surface(s).

6.

**Parts List:**

<b>Part No.</b>	<b>Pictures</b>	<b>Description</b>	<b>QTY</b>
A		Table leg	2
B		Table-rack	1
C		Glass table top	1

**Hardware Kit:**

<b>Part No.</b>	<b>Pictures</b>	<b>Description</b>	<b>QTY</b>
D		Bolt M6 x 15 mm	8
E		Allen Key	1

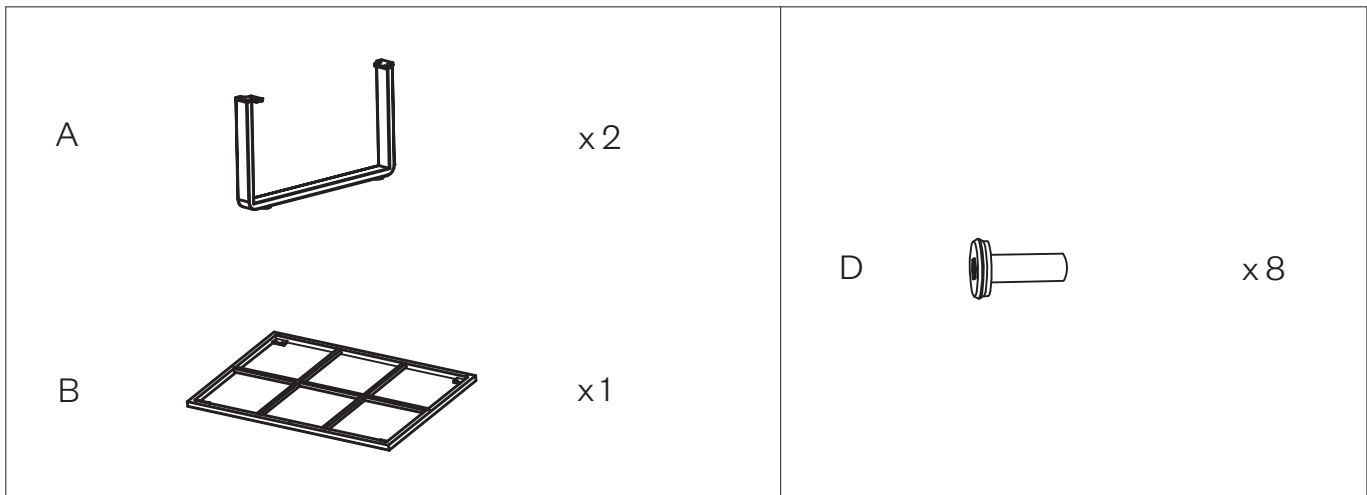
**Step 1:**

Fix the table legs (A) to the table-rack (B) with bolts (D).

Once all bolts are in position tighten securely using Allen Key (E).

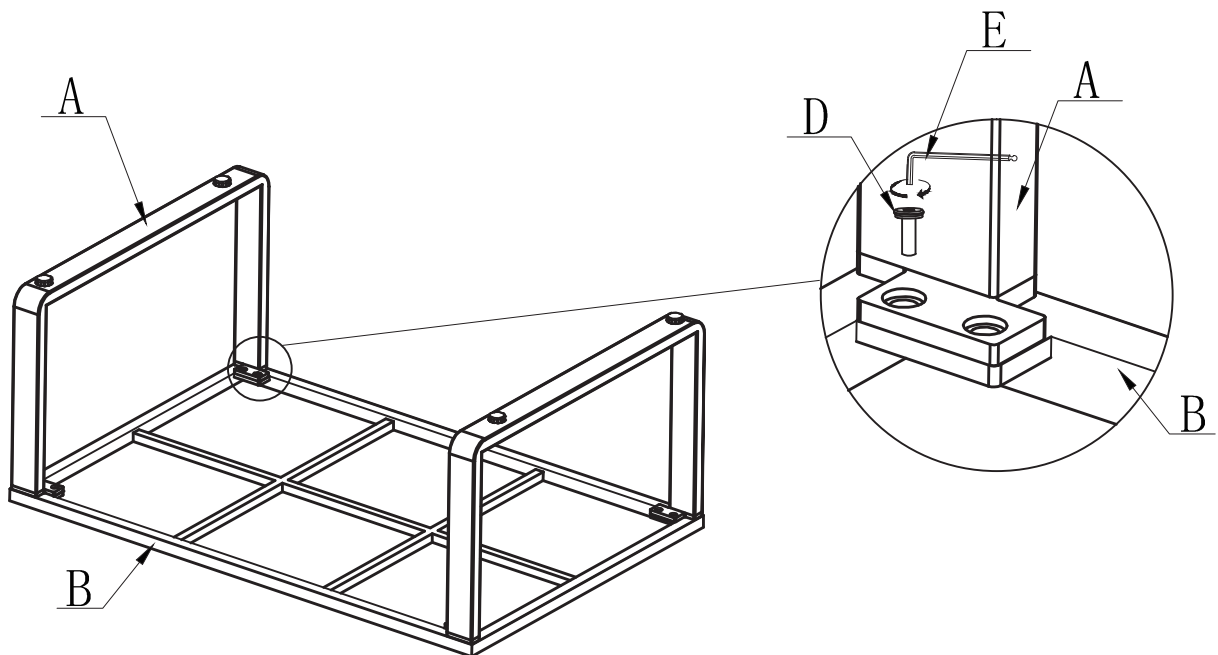

8.

C

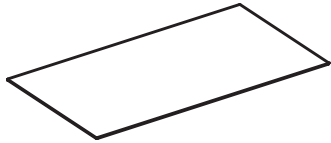

x1

**Step 2:**

Put the glass table top (C) on the table-rack (B).

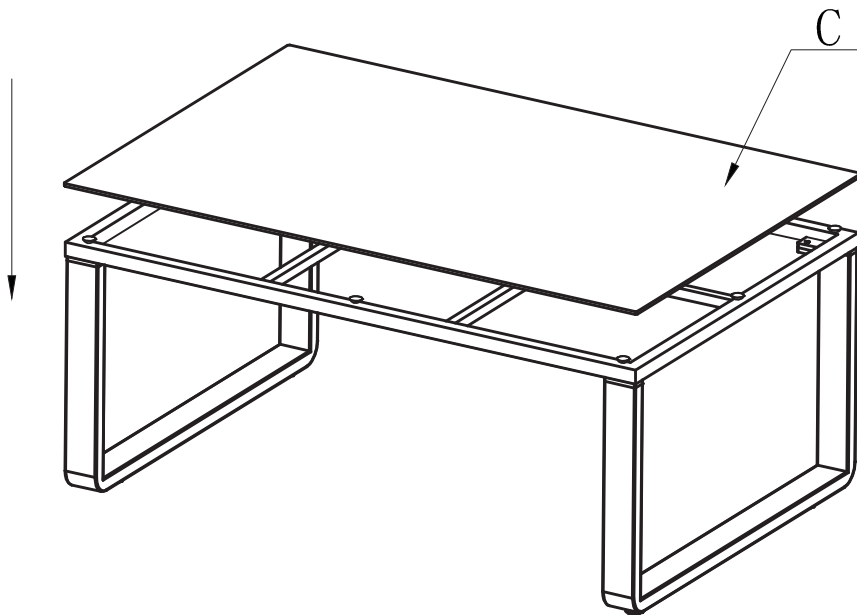

Coffee table is now ready for use.

