

Modular Handrail Installation Guide

WALL APPLICATION

see page 3



BALUSTRADE APPLICATION

see page 11

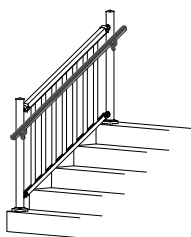

Tools and Materials Required

- Mitre saw with non-ferrous metal cutting blade
- Drill
- Drill bits: 3.5 mm, 6.5 mm, 9 mm
- Sockets or spanners: 10 mm, 11 mm
- Measuring tape
- Phillips #2 bit or screwdriver
- Stud finder
- Non-corrosive exterior silicone caulking
- Wall screws (see tables on pages 4 & 5)

Hardware Included

1x 1.8 m Handrail

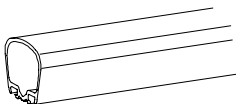

3x Brackets

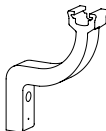

1x Splice



2x End caps



6x Screws



3x Connector bolts
(for balustrade application only)

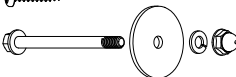

See WARNING on inside panel

Dear Customer,

We would like to take a moment to say “thank you and congratulations” for choosing our products.

At Peak® your satisfaction is very important to us. That is why we work very hard to provide you with products of exceptional quality, value, and beauty. And that is also why we want to hear from you.

*Please contact us with your comments or suggestions at:
**support@peakproducts.com.au or
support@peakproducts.co.nz***

Finally, we would like to remind you to always work safely. Then, take pride, relax with your family and experience years of enjoyment with Peak® products.

Sincerely,

Peak Products Corporation

WARNING No representation or warranty is given that your particular application of these products complies with relevant building codes or that the fasteners provided or used are appropriate for your application. Consult with professionals and local building officials before beginning work: (i) to ensure compliance with relevant building codes for your application and for your proposed use of fasteners; (ii) to ensure the integrity of the structural components in connection with which these products are to be used; (iii) to identify appropriate safety gear that is to be used during installation such as a safety harness when working above ground; (iv) to ensure that the work area is free from utilities, services and hazards; and (v) to clarify any instructions or warnings that may not be clear. Work in a safe manner wearing protective gear such as gloves, eyewear, headwear, footwear and clothing. When using tools comply with operation manuals and instructions. Metal and glass may have sharp edges and could fragment or splinter during or as a result of handling or cutting. Do not use these products in connection with any substance that is or may be harmful or corrosive to the products. Inspect and maintain these products and the structural components that they are used in connection with on a regular basis, using professionals when appropriate.

Peak Products Corporation shall not be liable for any loss or damage resulting from the improper installation or improper use of this product, subject to any contrary provision of the Australian Consumer Law in Australia or the Consumer Guarantees Act 1993 (NZ) in New Zealand.

Peak products and associated materials are protected by patents, designs, copyrights and/or trademarks.

WALL APPLICATION

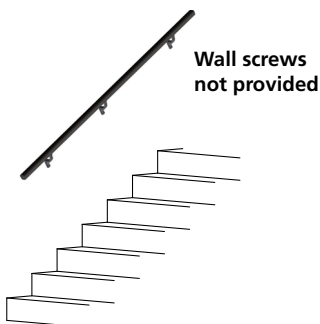

IMPORTANT INFORMATION

- Complies* with: Australian/New Zealand Standard AS/NZS 1170.0:2002 Structural design actions for domestic and residential activities.

* Conditions apply. For details visit:
peakbalustrade.com.au/compliance
or peakbalustrade.co.nz/compliance.

Complete Peak® Aluminium Handrail system required.

- Always understand and comply with your local building codes.
- To prevent timber splitting and rot, drill pilot holes and coat coach screw threads with non-corrosive exterior silicone caulking.
- As shown in Fig.1:
 - bracket spacing shall not exceed 1.36 m
 - comply with your local building codes for height of handrail above nose of stair tread or ramp
 - end of handrail shall not extend more than 300 mm past the end of the bracket
 - splice connections shall be located between any 2 brackets, and no more than 200 mm from any one bracket, and no closer to each other than the bracket spacing.

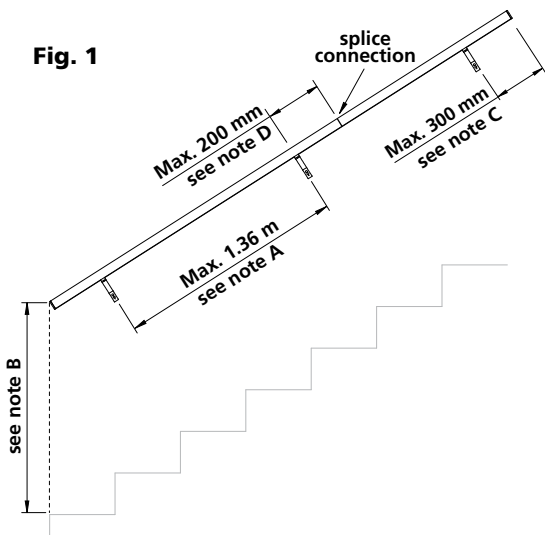



Anchoring fasteners for Australia

(for wall application only)

WARNING

Engineering design has determined appropriate fasteners for the attachment of the brackets to concrete or timber structures designed by others.

While the types of material are defined in the table below, the ability of the supporting structure to provide adequate support to Peak® Aluminium Handrail system and its fasteners must be independently verified for each installation.

To meet certain handrail load requirements within AS/NZS 1170.1:2002, purchase the following fasteners. Building codes may vary. Always understand and comply with your local building codes. For further information visit: peakbalustrade.com.au/compliance

Fasteners for attaching brackets to concrete:

Concrete	Fasteners Required	Minimum Embedment ¹	Minimum Edge Distance
Minimum concrete strength 25 MPa	1x Ramset™ WERCS Ankascrew™ anchor, M8 x 75 mm	51 mm	70 mm
	1x Ramset™ Ankascrew™ anchor, M8 x 75 mm		

Fasteners for attaching brackets to timber:

Timber	Fasteners Required	Minimum Embedment ¹	Minimum End and Edge Distance
JD3 - e.g. Seasoned, Mixed Australian Hardwood	1x M8 Coach Screw ²	60 mm	End: 64 mm Edge: 32 mm
	1x 18G Wood Screw ³	60 mm	End: 73 mm Edge: 54 mm
J3 - e.g. Unseasoned, Mixed Australian Hardwood	1x M8 Coach Screw ²	65 mm	End: 64 mm Edge: 32 mm
	1x 18G Wood Screw ³	90 mm	End: 73 mm Edge: 54 mm
JD4 - e.g. Seasoned, Mixed Softwood Species	1x M8 Coach Screw ²	65 mm	End: 64 mm Edge: 32 mm
	1x 18G Wood Screw ³	80 mm	End: 73 mm Edge: 54 mm
J4 - e.g. Unseasoned, Pine, Radiata, Australia	1x M8 Coach Screw ²	80 mm	End: 64 mm Edge: 32 mm
	1x 18G Wood Screw ³	115 mm	End: 73 mm Edge: 54 mm

¹ Depth of the threaded portion of the screw into the innermost member.

² Material of steel coach screws shall be given in AS/NZS 4291.1, for property classes 4.6 and 4.8.

³ Steel material strength of the 18G (7.72 mm) wood screw shall meet the requirements of AS 1720.1.



Anchoring fasteners for New Zealand (for wall application only)

WARNING

Engineering design has determined appropriate fasteners for the attachment of the brackets to concrete or timber structures designed by others.

While the types of material are defined in the table below, the ability of the supporting structure to provide adequate support to Peak® Aluminium Handrail system and its fasteners must be independently verified for each installation.

To meet certain handrail load requirements within AS/NZS 1170.1:2002, purchase the following fasteners. Building codes may vary. Always understand and comply with your local building codes. For further information visit: peakbalustrade.co.nz/compliance

Fasteners for attaching brackets to concrete:

Concrete	Fasteners Required	Minimum Embedment ¹	Minimum Edge Distance
Minimum concrete strength 25 MPa	1x Ramset™ WERCS Ankascrew™ anchor, M8 x 75 mm	51 mm	70 mm
	1x Ramset™ Ankascrew™ anchor, M8 x 75 mm		

Fasteners for attaching brackets to timber:

Timber	Fasteners Required	Minimum Embedment ¹	Minimum End and Edge Distance
J1	1x M8 Coach Screw ²	35 mm	End: 40 mm Edge: 32 mm
J2	1x M8 Coach Screw ²	45 mm	End: 40 mm Edge: 32 mm
J3	1x M8 Coach Screw ²	75 mm	End: 40 mm Edge: 32 mm
J4 - e.g. Unseasoned, Pine, Radiata, Australia	1x M8 Coach Screw ²	80 mm	End: 40 mm Edge: 32 mm
	1x 18G Wood Screw ³	90 mm	End: 80 mm Edge: 40 mm
J5 - e.g. Radiata Pine, Rimu, Douglas Fir, Larch	1x M8 Coach Screw ²	100 mm	End: 40 mm Edge: 32 mm
	1x 18G Wood Screw ³	90 mm	End: 80 mm Edge: 40 mm

¹ Depth of the threaded portion of the screw into the innermost member.

² Material of steel coach screws shall be given in AS/NZS 4291.1, for property classes 4.6 and 4.8.

³ Steel material strength of the 18G (7.72 mm) wood screw shall meet the requirements of AS 1720.1.

INSTALLATION

1. Determine the quantity of 1.8 m Handrail Kits you will need.
Note: A total length of handrail greater than 1.8 m will require multiple kits.
-

2. **▲IMPORTANT** Only complete this step if your installation requires 2 wall anchors for each bracket (check local building codes).

Drill a 9 mm hole at the marked location on each bracket.

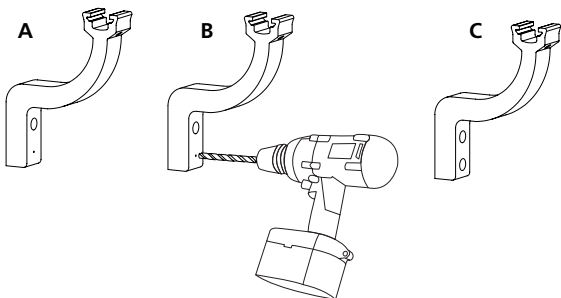

3. Measure and mark the position of all brackets on the wall. For timber applications only, use a stud finder to ensure the brackets are located over solid wood.

▲IMPORTANT Comply with your local building codes for height of handrail above nose of stair tread or ramp. Do not exceed 1.36 m maximum bracket spacing (see Fig. 1 on page 3).

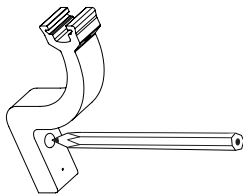

4. Starting at the top, install a screw to fasten the top bracket to the wall (see fastener tables on pages 4 & 5). Tighten the screw until the bracket is secure but can rotate freely.

▲IMPORTANT Follow manufacturer's instructions for wall screw installation.

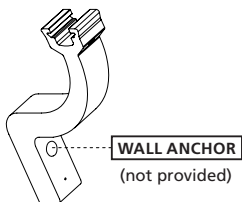

5. ⚠️ IMPORTANT Only complete this step for handrails longer than 1.8 m.

To join two handrails together, insert splice 64 mm into first handrail. Drill 3.5 mm pilot holes through handrail and splice, then install two screws. Attach second handrail to other side of splice using the same procedure.

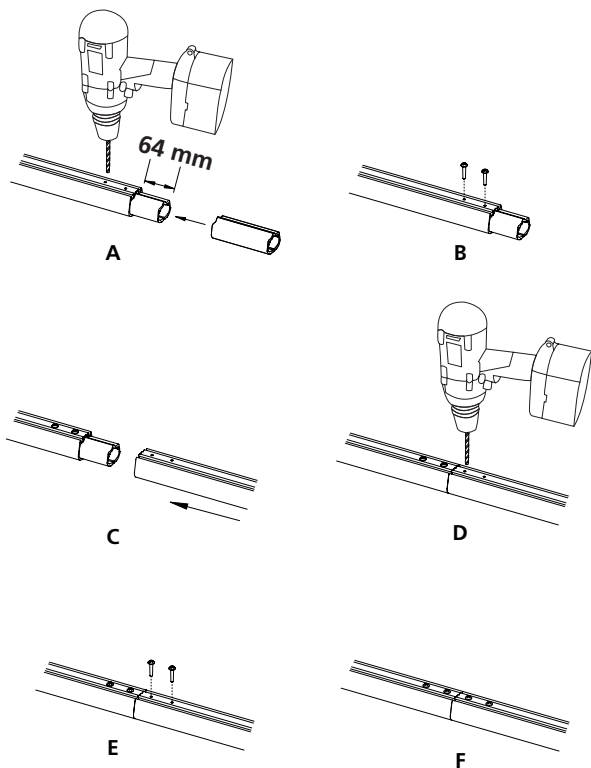

6. Measure and cut the handrail to the desired length, then slide the handrail onto the top bracket.

⚠️ IMPORTANT Always wear eye protection.

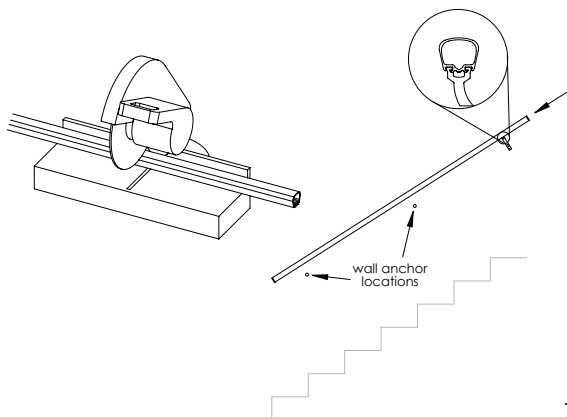

- 7.** Once in position, drill a 3.5 mm pilot hole through the bracket and into the handrail. Fasten the bracket to the handrail with a screw (provided).

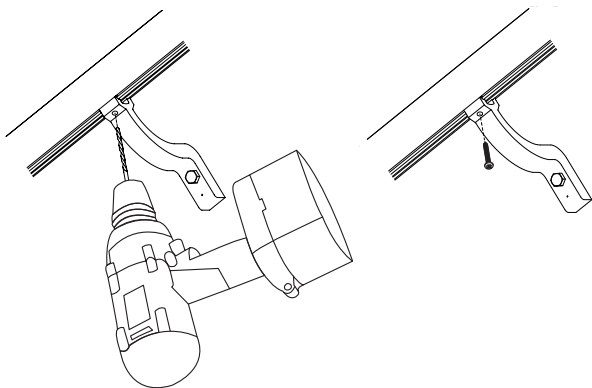

-
- 8.** From the bottom end, slide the required number of brackets into the underside of the handrail.

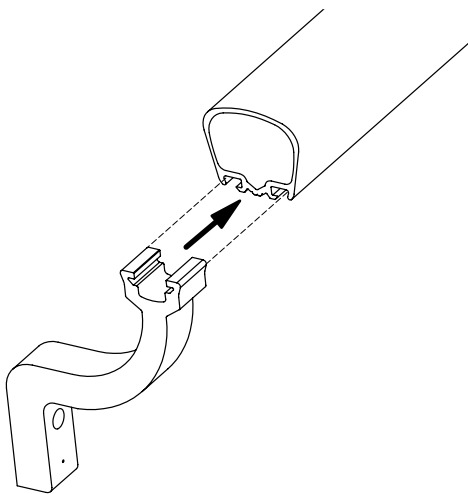

- 9. With the help of another person,** adjust the handrail height and slide the bracket(s) into the marked positions. Then follow step 4 to attach the bracket(s) to the wall.

▲IMPORTANT Do not exceed 1.36 m maximum bracket spacing (see Fig. 1 on page 3).

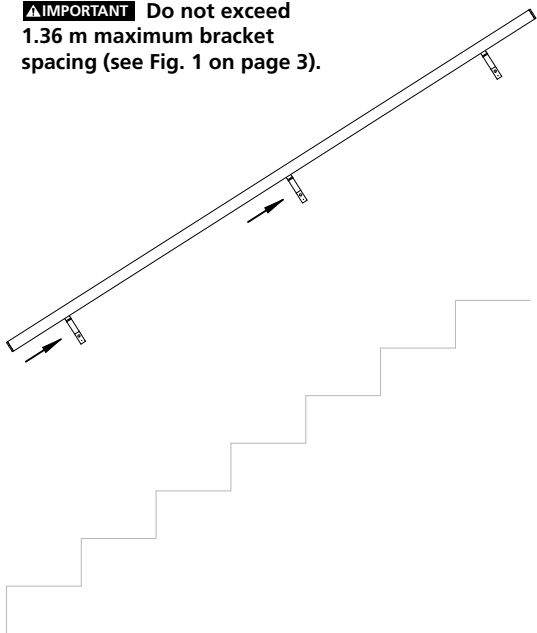

-
- 10.** Follow step 7 to fasten the remaining bracket(s) to the handrail.
-

- 11.** Tighten the wall screw(s) on each bracket.

▲IMPORTANT Do not over tighten.

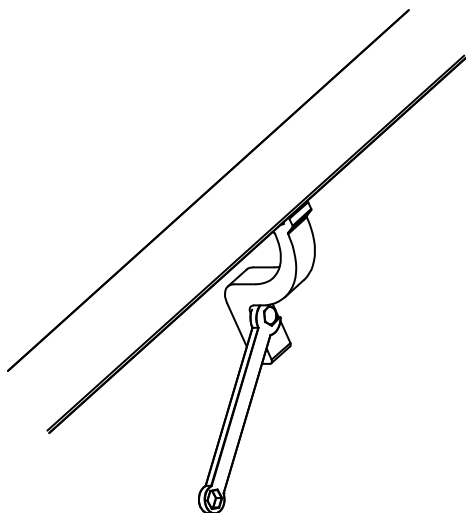

12. Slide an end cap into each end of the handrail.

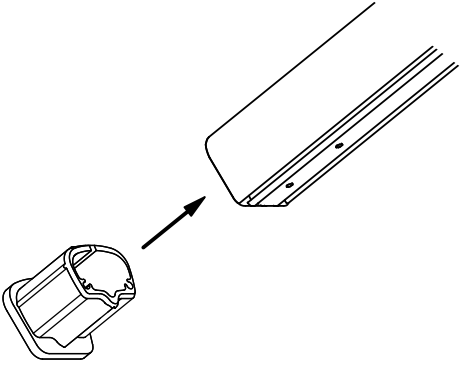

13. Drill 3.5 mm pilot holes through handrail and end caps at each end of handrail.

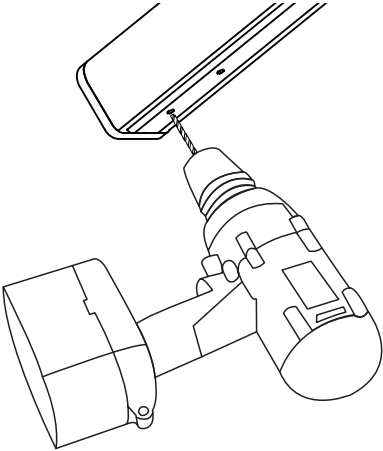

14. Secure end caps with screws (provided) at each end of handrail.

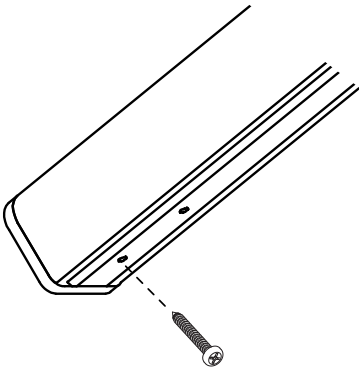

BALUSTRADE APPLICATION

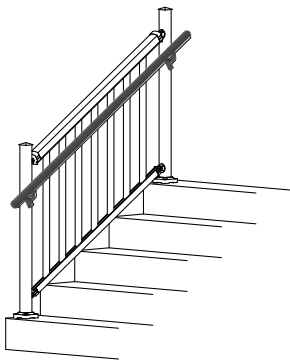

IMPORTANT INFORMATION

- Complies* with: Australian/New Zealand Standard AS/NZS 1170.0:2002 Structural design actions

* Conditions apply. For details visit:
peakbalustrade.com.au/compliance
or peakbalustrade.co.nz/compliance.

Complete Peak® Aluminium Handrail system required.

- Always understand and comply with your local building codes.
- As shown in Fig. 2:

- A. bracket spacing shall not exceed 1.36 m
- B. comply with your local building codes for height of handrail above nose of stair tread or ramp
- C. end of handrail shall not extend more than 300 mm past the end of the bracket
- D. splice connections shall be located between any 2 brackets, and no more than 200 mm from any one bracket, and no closer to each other than the bracket spacing.

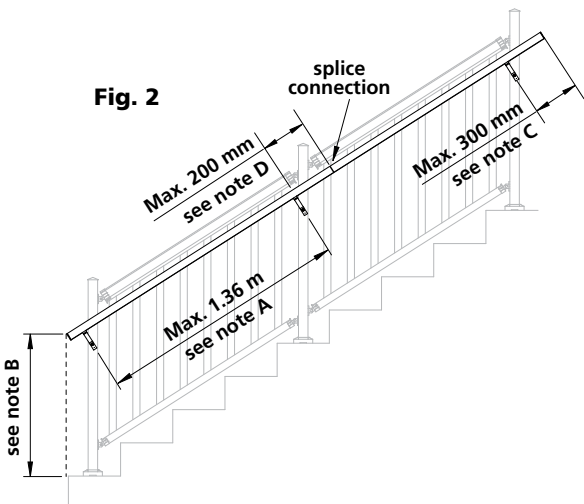

INSTALLATION

1. Determine the quantity of 1.8 m Handrail Kits you will need.
Note: A total length of handrail greater than 1.8 m will require multiple kits.

2. Starting at the top of the balustrade, measure and mark the position of the top bracket on the balustrade post. Ensure the hole is centred on the balustrade post at the desired height.

▲ IMPORTANT Comply with your local building codes for height of handrail above nose of stair tread or ramp. Do not exceed 1.36 m maximum bracket spacing (see Fig. 2 on page 11).

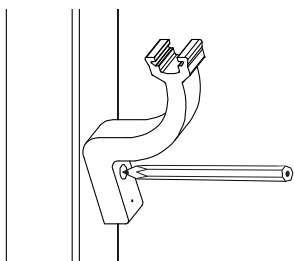

3. Drill a 6.5 mm hole through the balustrade post at the marked position.

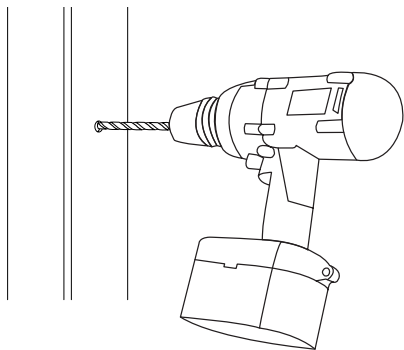

4. Fasten the bracket to the balustrade post using a connector bolt (provided). Tighten until the bracket is secure but can rotate freely.

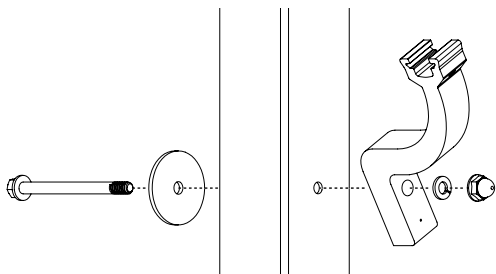

5. ⚠ IMPORTANT Only complete this step for handrails longer than 1.8 m.

To join two handrails together, insert splice 64 mm into first handrail. Drill 3.5 mm pilot holes through handrail and splice, then install two screws. Attach second handrail to other side of splice using the same procedure.

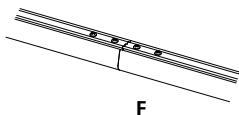
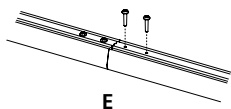
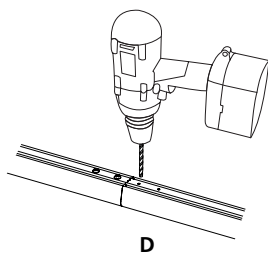
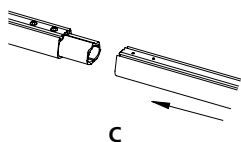
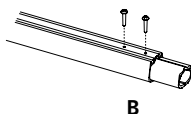
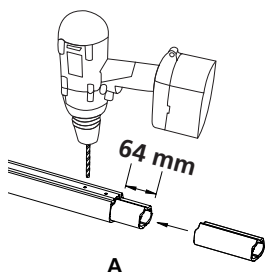

6. Measure and cut the handrail to the desired length, then slide the handrail onto the top bracket.

⚠ IMPORTANT Always wear eye protection.

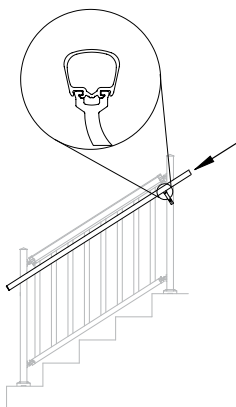
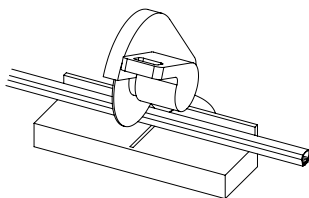

- 7.** Once in position, drill a 3.5 mm pilot hole through the bracket and into the handrail. Fasten the bracket to the handrail with a screw (provided).

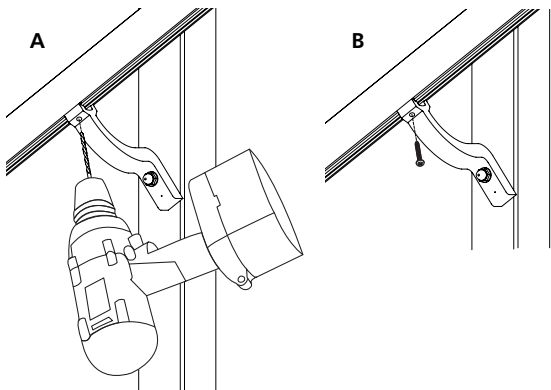

-
- 8.** From the bottom end, slide the required number of brackets into the handrail channel.

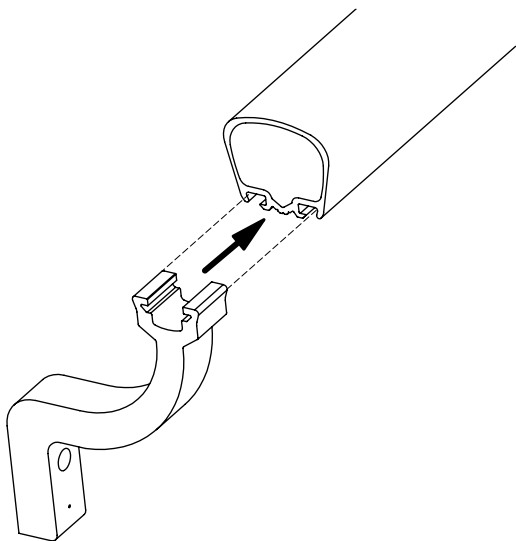

- 9.** With the help of another person, adjust the handrail to the desired height and centre the remaining bracket(s) on the balustrade post(s). Mark position of bracket(s) on the balustrade post(s) and drill 6.5 mm hole(s) through the balustrade post(s) at marked position(s). Then follow step 4 to attach the bracket(s) to the balustrade post(s).

▲IMPORTANT Do not exceed 1.36 m maximum bracket spacing (see Fig. 2 on page 11).

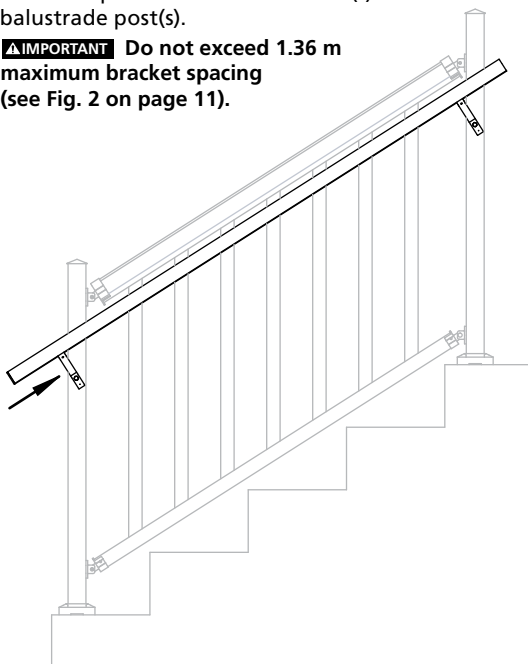

- 10.** Follow step 7 to fasten the remaining bracket(s) to the handrail.

- 11.** Tighten the bolt on each bracket.

▲IMPORTANT Do not over tighten.

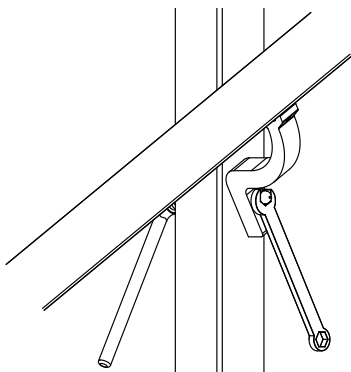

12. Slide an end cap into each end of the handrail.

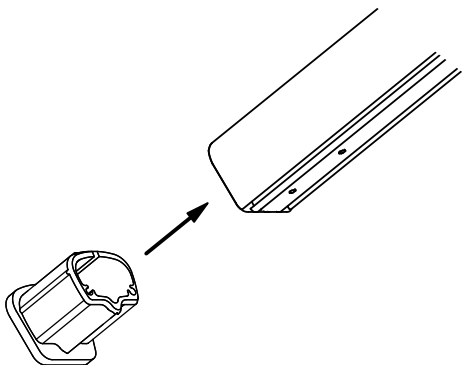

13. Drill 3.5 mm pilot holes through handrail and end caps at each end of handrail.

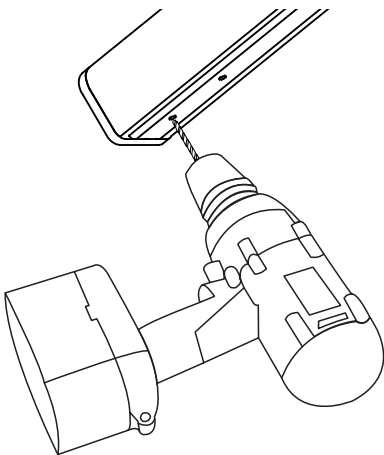

14. Secure end caps with screws (provided) at each end of handrail.

