

ozito

DOUBLE BEVEL SLIDING COMPOUND MITRE SAW

254MM (10")

INSTRUCTION MANUAL

SPECIFICATIONS

Mains Voltage:	230–240V ~ 50Hz
Motor Power:	2100W (S1); 2350W (S6 25%)
No Load Speed:	4,000/min
Blade:	Ø254 x Ø25.4 x 3.0mm (48T)
Mitre / Bevel Angle:	0–45° Left & Right
Max. Cutting Capacities:	
Mitre 0° x Bevel 90°:	75 x 320mm
Mitre 45° x Bevel 90°:	75 x 220mm
Mitre 0° x Bevel 45°:	45 x 320mm
Mitre 45° x Bevel 45°:	42 x 220 (Left); 25 x 220mm (Right)
Weight:	16kg

ozito.com.au

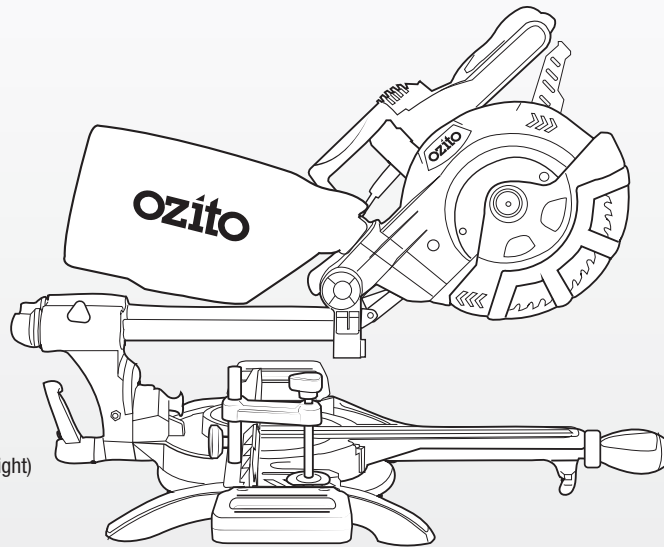

STANDARD EQUIPMENT

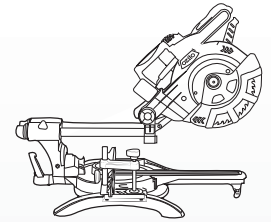

Sliding Compound Mitre Saw

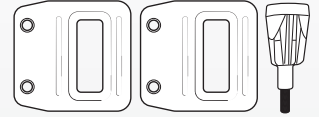

2 x Material Support Bars & Mitre Table Lock



2 x Hex Keys, 4 x Bolts & Dust Bag

3 YEAR
REPLACEMENT
WARRANTY*

SCMS-2125

WARRANTY

IN ORDER TO MAKE A CLAIM UNDER THIS WARRANTY YOU MUST RETURN THE PRODUCT TO YOUR NEAREST BUNNINGS WAREHOUSE WITH YOUR BUNNINGS REGISTER RECEIPT. PRIOR TO RETURNING YOUR PRODUCT FOR WARRANTY PLEASE TELEPHONE OUR CUSTOMER SERVICE HELPLINE:

Australia: 1800 069 486

New Zealand: 0508 069 486

TO ENSURE A SPEEDY RESPONSE PLEASE HAVE THE MODEL NUMBER AND DATE OF PURCHASE AVAILABLE. A CUSTOMER SERVICE REPRESENTATIVE WILL TAKE YOUR CALL AND ANSWER ANY QUESTIONS YOU MAY HAVE RELATING TO THE WARRANTY POLICY OR PROCEDURE.

The benefits provided under this warranty are in addition to other rights and remedies which are available to you at law.

Our goods come with guarantees that cannot be excluded at law. You are entitled to a replacement or refund for a major failure and for compensation for any other reasonably foreseeable loss or damage. You are also entitled to have the goods repaired or replaced if the goods fail to be of acceptable quality and the failure does not amount to a major failure.

Generally you will be responsible for all costs associated with a claim under this warranty, however, where you have suffered any additional direct loss as a result of a defective product you may be able to claim such expenses by contacting our customer service helpline above.

3 YEAR REPLACEMENT WARRANTY*

Your product is guaranteed for a period of **36 months from the original date of purchase**. If a product is defective it will be replaced in accordance with the terms of this warranty. Warranty excludes consumable parts, for example: valve adapters and accessories.

*This product is intended for DIY use only and replacement warranty covers domestic use.

WARNING

The following actions will result in the warranty being void.

- If the tool has been operated on a supply voltage other than that specified on the tool.
- If the tool shows signs of damage or defects caused by or resulting from abuse, accidents or alterations.
- Failure to perform maintenance as set out within the instruction manual.
- If the tool is disassembled or tampered with in any way.
- Professional, industrial or high frequency use.

KNOW YOUR PRODUCT

DOUBLE BEVEL SLIDING MITRE SAW

- | | |
|--------------------------|--------------------------------------|
| 1. On/Off Trigger | 14. Bevel Angle Pointer |
| 2. Cutting Handle | 15. Trenching Depth Adjustment Screw |
| 3. Laser On/Off Switch | |
| 4. Motor | |
| 5. Spindle Lock Button | |
| 6. Lock Down Pin | |
| 7. Laser | |
| 8. Upper Fence | |
| 9. Mounting Point | |
| 10. Mitre Table | |
| 11. Mitre Angle Pointer | |
| 12. Fence | |
| 13. Material Support Bar | |

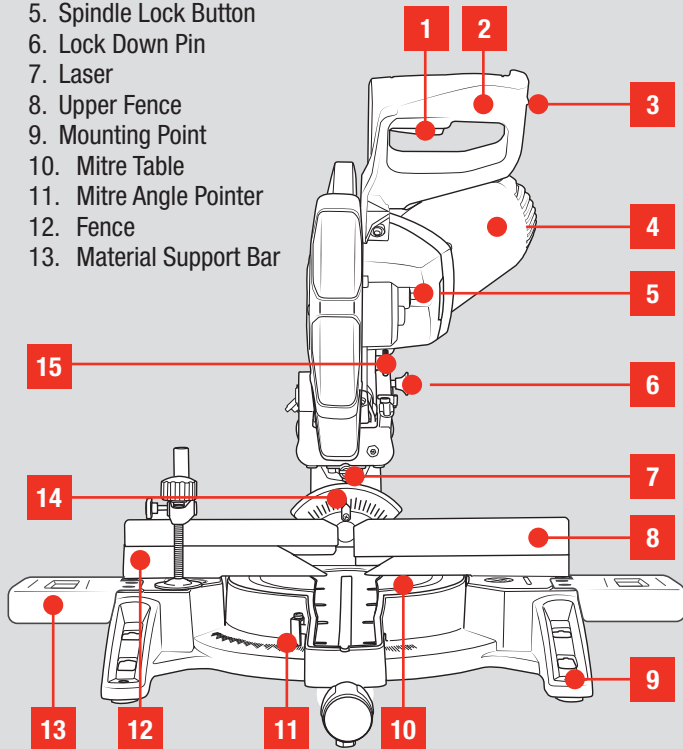

- | | |
|--------------------------|-----------------------------|
| 16. Slide Lock | 23. Retractable Blade Guard |
| 17. Bevel Release Knob | 24. Material Clamp |
| 18. Slide Bar | 25. Mitre Table Lock |
| 19. Dust Bag | 26. Table Stop |
| 20. Carry Handle | 27. Table Insert |
| 21. Safety Release Lever | 28. Upper Fence Lock |
| 22. Saw Blade | 29. Bevel lock |

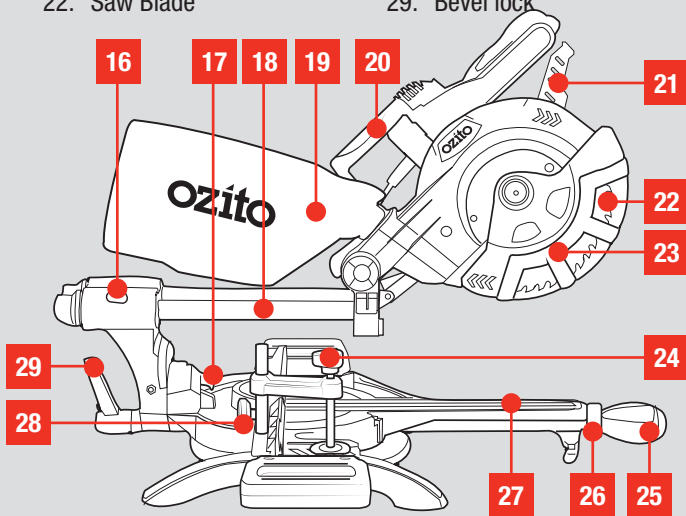

ONLINE MANUAL

Scan this QR Code with your mobile device to take you to the online manual.



3 YEAR REPLACEMENT WARRANTY*

SETUP & PREPARATION

1. ASSEMBLY

WARNING! ENSURE THE TOOL IS TURNED OFF AND DISCONNECTED FROM THE POWER SUPPLY BEFORE PERFORMING ANY OF THE FOLLOWING OPERATIONS.

Unpacking

- Remove foam packaging materials and using the carry handle, carefully lift the mitre saw from its box and place it on a level work surface.

- Release cutting head from its transport position. While holding the head of the saw down release the lock down pin.

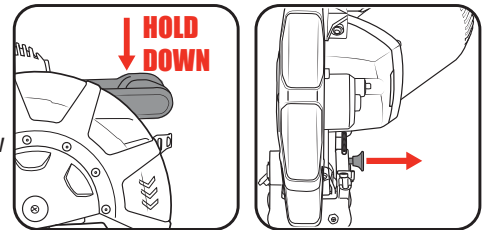

Dust Bag

- Squeeze the clamp at the end of the dust bag, place over the dust extraction port.

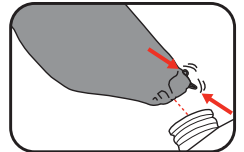

Note: The dust extraction port can block easily with dust and requires to be periodically cleaned. For more efficient operation, empty the dust bag when it is no more than half full. This allows better air flow through the bag. Dust bags will not collect all the saw dust generated by the mitre saw. For best results a dust extractor should be used in place of the dust bag.

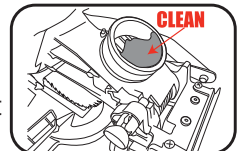

Mitre Table Lock

Align the table lock with the hole in the mitre table arm. Turn clockwise to attach it. Tighten fully to secure the mitre table angle in place.

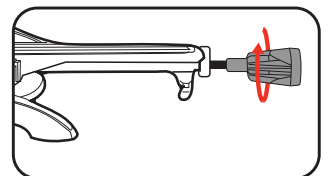

Material Support Bars

- Align a material support bar with the slot in the mitre saw base.
- Insert 2 bolts and use the provided hex key to tighten these in place.
- Repeat steps 1 & 2 for the other side.

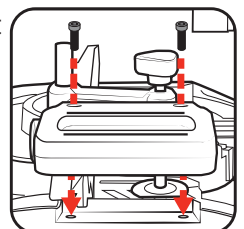

2. SETUP & ADJUSTMENTS

Securing The Mitre Saw

The base of the saw has four mounting holes (1 in each corner) that can be used to mount it to a workbench or mitre saw stand. Use four bolts (not included) to secure it in place.

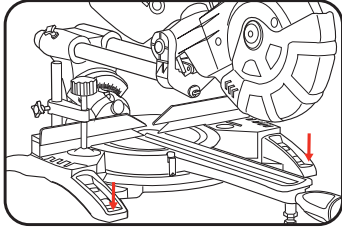

Slide Lock

When cutting a narrow piece of wood it is not necessary to use the slide mechanism. In these circumstances, push back the cutting head and ensure the slide locking knob is tight to prevent the cutting head from sliding.

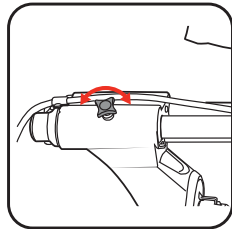

Mitre Angle Adjustments

1. Loosen mitre table lock

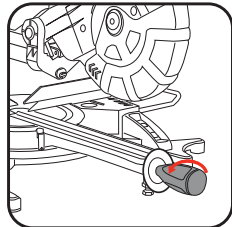

2. Pull the table stop and rotate the mitre table to the desired mitre angle (left or right) as shown by the mitre angle pointer

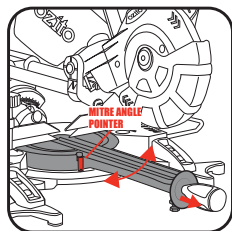

Note: The mitre table features positive click stops at 0°, 15°, 22.5°, 31.6° and 45° for quick setting of common mitre angles.

3. Tighten mitre table lock at selected angle.

WARNING! ENSURE THE MITRE TABLE LOCK IS TIGHT BEFORE MAKING A CUT. FAILURE TO DO SO MAY RESULT IN THE MITRE TABLE MOVING DURING OPERATION & CAUSE SERIOUS PERSONAL INJURY.

Bevel Angle Adjustment

WARNING! MOVE THE MATERIAL CLAMP TO THE OPPOSITE SIDE OF THE BEVEL DIRECTION. THIS ALLOWS THE CUTTING HEAD TO TILT THE FULL 45°.

1. Loosen the bevel lock.

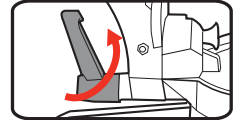

2. To bevel **RIGHT**, tilt the cutting head slightly left and pull the bevel release. Then tilt the cutting head rightward to the desired bevel angle.

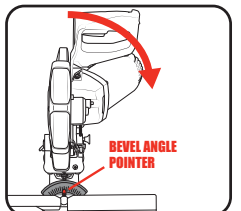
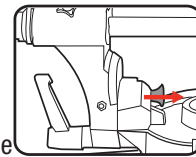

To bevel **LEFT**, tilt the cutting head to the desired bevel angle.

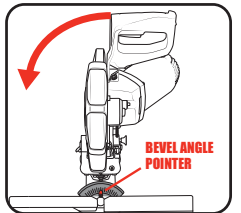

3. Tighten the bevel lock to lock the angle in place.

WARNING! ENSURE THE BEVEL LOCK IS TIGHT BEFORE MAKING A CUT. FAILURE TO DO SO MAY RESULT IN THE CUTTING HEAD MOVING DURING OPERATION & CAUSE SERIOUS PERSONAL INJURY.

Trenching

Trenching refers to restricting the depth of cut and permits a "trench" to be cut in the workpiece.

1. Ensure the cutting head is raised, move the trenching stop to the right as far as it will go.

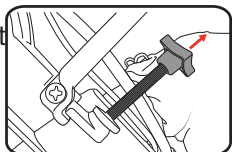

2. To adjust the trenching depth rotate the trenching depth adjustment screw.

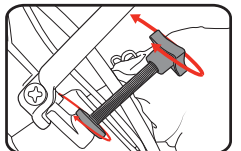

3. To check that the blade stops at the desired position, lower the cutting head until the trenching stop adjustment screw touches the trenching stop.

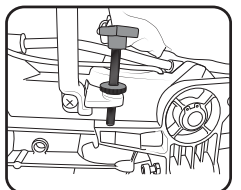

4. When the correct depth is set. Lock it in position using the trenching depth lock nut.

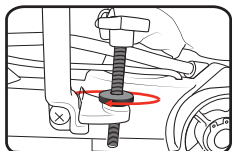

Note: It is recommended to test the depth set is correct on a scrap piece of wood.

OPERATION

Fence

The fence holds the workpiece in a fixed position while the table and/or the blade assembly are adjusted in a mitre or bevel angle. To make accurate cuts, the fence must be perpendicular (at a 90° angle) to the saw blade.

Make sure that no part of the tool contacts the upper fence when bevel or compound mitre cutting. Always make a dry run with the saw turned off and check clearance.

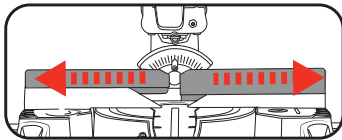

Note: Tighten the upper fence lock before making a cut.

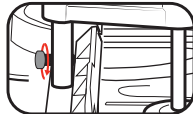

The fence may become misaligned over time, so always perform a test cut on a scrap piece of material beforehand. Follow the steps below to re-align the fence.

1. With the saw switched off and unplugged from the power source, set the mitre angle to 0° and loosen the 4 screws on the top of the fence.

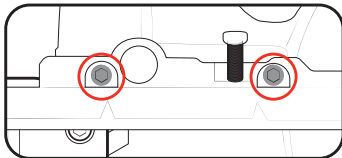

2. Flip the safety guard lever, lower the cutting head and hold it in place using the lock down pin.

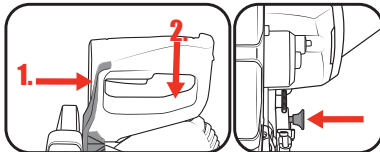

3. Hold a set square against the blade and adjust the fence till it lines up against the square.

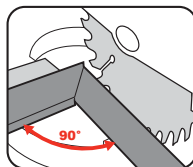

Note: The square must contact the blade, not the teeth, for an accurate reading.

4. Tighten the fence screws to lock it in place.

Material Clamp

Depending on the cut, the material clamp will need to be mounted on the appropriate side. When performing bevel cuts, the work clamp must be on the opposite side of the bevel (otherwise it will interfere with the cutting action).

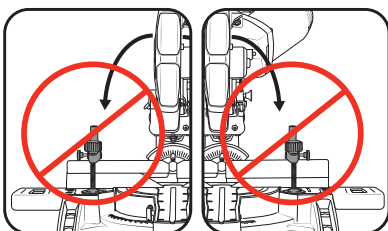

WARNING! ENSURE THE MATERIAL IS SECURELY CLAMPED BEFORE MAKING ANY CUTS. FAILURE TO SECURE THE MATERIAL MAY CAUSE THE WORKPIECE TO FLY OFF AND CAUSE PERSONAL INJURY.

3. TYPES OF CUTS

WARNING! THE TOOL IS RECOMMENDED FOR USE WITH A RESIDUAL CURRENT DEVICE WITH A RATED RESIDUAL CURRENT OF 30MA OR LESS.

Laser Guide

WARNING! DO NOT STARE DIRECTLY AT THE LASER BEAM.

A laser line is projected onto the material you wish to cut, providing an exact guide for the cut.

1. To switch the laser guide on, press the laser guide switch to the On (I) position.
2. To switch the laser guide off, press the laser guide switch to the Off (O) position.

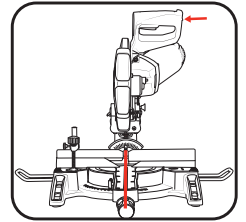

Note: Ensure that the laser guide is switched off when the saw is not in use.

Note: Ensure that the laser is cleaned after every use or the laser guide will not be visible.

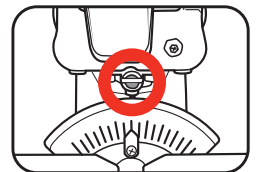

Workpiece

Place the workpiece flat on the mitre table with one edge securely against the rear fence.

Note: If the workpiece is warped, ensure the concave (curves inward) side is against the rear fence.

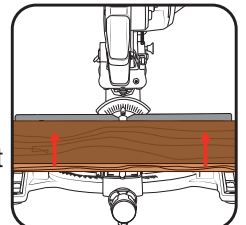

WARNING! ADEQUATE SUPPORT SUCH AS TABLE EXTENSIONS, SAW HORSES, ETC. MUST BE USED FOR A WORKPIECE THAT IS WIDER OR LONGER THAN THE TABLE TOP. FAILURE TO DO SO MAY LEAD TO INJURY OR DAMAGE TO THE TOOL.

It is extremely important to always secure the workpiece properly and tightly with the material clamp.

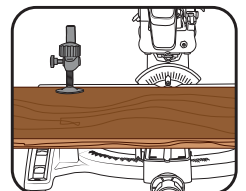

Spindle Lock

WARNING! NEVER PRESS WHEN BLADE IS ROTATING.

The spindle lock prevents the blade in the saw from rotating. Depress and hold the spindle lock while installing, changing, or removing the blade.

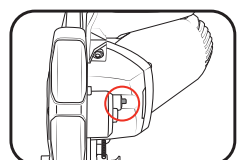

4. USAGE

Retractable Safety Guard

The lower guard provides protection to your hands and limbs when the mitre saw head is in the up position. During the operation of the saw, when the saw is turned on and you are making a cut, the lower guard retracts over the upper guard as the saw is lowered into the work piece.

1. To retract the lower guard, slide the release lever right with your thumb and press handle down.

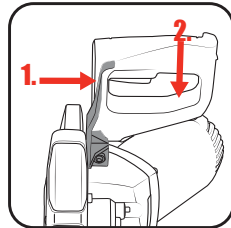

Turning The Saw On

1. To turn the mitre saw on, squeeze the trigger switch.
2. To turn the mitre saw off, release the trigger switch.

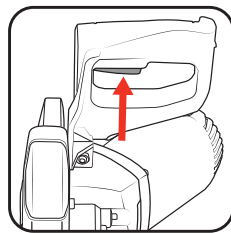

Note: Before performing a cut, ensure the blade is at full speed. Failure to do this may cause the blade to become blunt and cause the blade to lock-up.

Slide Action

When cutting wide pieces of wood, ensure the slide lock is loose.

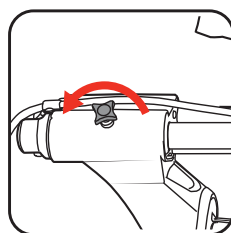

1. First pull carriage fully forwards, slide the release lever right with your thumb and press handle down.

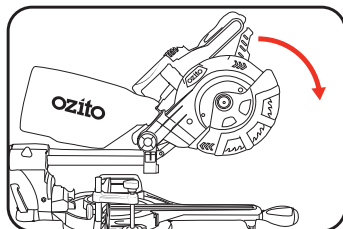

2. Push carriage toward the rear fence.

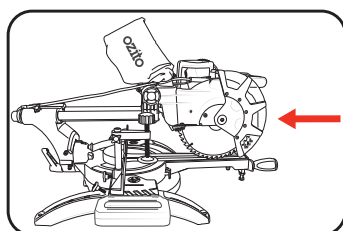

WARNING! DO NOT USE THE MITRE SAW TO CUT METAL OR MASONRY.

WARNING! FOR ALL TYPES OF CUTS, ENSURE THAT THE SAW IS LOCKED INTO POSITION.

Straight Cutting

A straight cut is made by cutting the grain of the workpiece. A 90° straight cut is made with the mitre scale set in the 0°.

Max. cutting capacity wood: 75 x 320mm

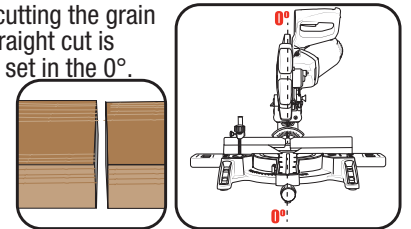

Mitre Cuts

Mitre cuts are made with the mitre scale set at an angle other than 0°

Max. cutting capacity wood: 75 x 220mm

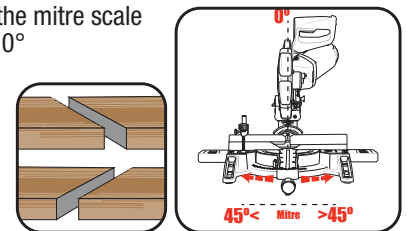

Bevel Cutting

A bevel cut is made by cutting across the grain of the workpiece with the blade angled to the mitre table.

Max. cutting capacity wood: 45 x 320mm

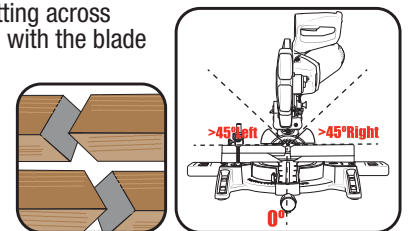

WARNING! ENSURE THE REAR FENCE IS ADJUSTED FOR BLADE CLEARANCE BEFORE BEVELLING.

Compound Mitre Cuts

A compound mitre cut involves using a mitre angle and a bevel angle at the same time.

Max. cutting capacity wood: 42 x 220mm (Left), 25 x 220mm (Right)

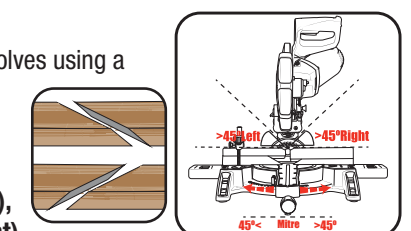

MAINTENANCE

5. TROUBLESHOOTING

Symptom	Possible Cause	Suggested Solution
Mitre saw will not start.	No power at power point.	Check that the power switch is on.
	Cord not connected.	Check that the cord is plugged in.
Mitre saw operates sporadically or at low power.	Low power supply or improper extension cord.	Inspect power supply or power cords.
	Worn or cracked carbon brushes.	Inspect carbon brushes; replace if damaged or worn.
Wood burns at ends of cut	Dirty blade.	Clean blade using blade cleaner or mineral spirits.
	Material is binding.	Check position of workpiece on table. Material must be flat, flush against fence & supported on ends.
Workpiece frays or chips out.	Finished side is down.	Keep finished side of workpiece up or facing operator.
	Blade chipped or dull.	Check for damaged teeth. Sharpen or replace blade.
	Blade inappropriate for material.	Check blade manufacturer's recommendations for material being cut. For cross cutting hardwood & for precision cuts, use a thin kerf blade with 60 or more teeth.
	Workpiece is unsupported.	Use a thin piece of scrap material, such as 6mm plywood underneath or behind the workpiece to support the edges of the workpiece as it is being cut.
Blade binds, slowing or stopping the saw.	Workpiece is misaligned or the ends are not supported.	Workpiece must be flat on table, flush against the fence & supported on both ends.
	Workpiece is wet, contaminated or inappropriate blade is being used.	Check condition of workpiece & check compatibility of blade to workpiece.
Blade does not cut completely through workpiece.	Depth stop setting in use.	Move depth stop to right to disengage.
	Depth stop set too shallow.	Adjust depth stop bolt for desired depth of cut.
Laser is not visible	Laser is blocked by dust/foreign particles	Wipe the laser lens gently with a dry soft cloth. Ensure the unit is switched off before doing so. Do not stare directly into the laser. Always check the laser on a workpiece.



WARNING! BEFORE CLEANING THE TOOL OR CARRYING OUT ANY MAINTENANCE PROCEDURE, MAKE SURE THAT IT IS DISCONNECTED FROM THE POWER SUPPLY TO PREVENT ACCIDENTAL STARTING.

Carbon Brushes

When the carbon brushes wear out, the mitre saw will spark and/or stop. Discontinue use as soon as this happens. They should be replaced prior to recommencing use of the mitre saw. Carbon brushes are a wearing component of the mitre saw therefore not covered under warranty. Continuing to use the mitre saw when carbon brushes need to be replaced may cause permanent damage to the mitre saw. Carbon brushes will wear out after many uses but when the carbon brushes need to be replaced, take the mitre saw to an electrician or a power tool repairer for a quick and low cost replacement. Always replace both carbon brushes at the same time.

Note: A small amount of sparking may be visible through the housing vents. This is normal and does not indicate a problem.

Slide Bar

Periodically apply WD40 or rust prevention oil to the metal slide bar. This is especially important if the tool is left in storage for long periods of time.

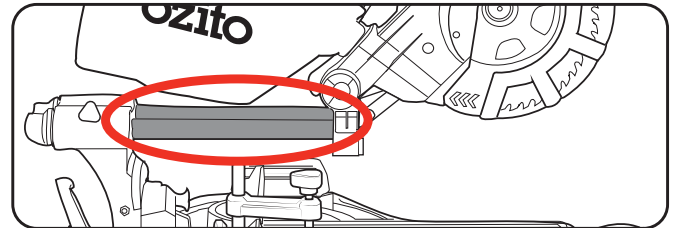

Transportation

The lock down pin is provided for holding the cutting head down whilst transporting or storing the mitre saw. The saw must never be used with the lock down pin locking the head down. Tighten the slide lock during transportation

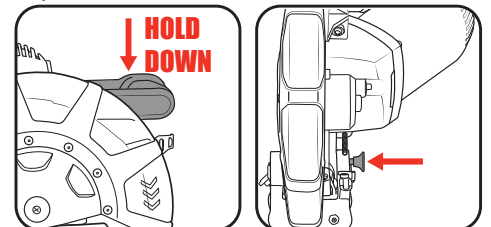

Supply Cords

If the supply cord is damaged, it must be replaced by an electrician or a power tool repairer in order to avoid a hazard.

Note: Ozito Industries will not be responsible for any damage or injuries caused by the repair of the mitre saw by an unauthorised person or by mishandling of the mitre saw.

DESCRIPTION OF SYMBOLS

V	Volts	Hz	Hertz
~	Alternating current	W	Watts
/min	Revolutions or reciprocation per minute	no	No load speed
	Warning		R.C.M. Regulatory compliance mark
	Read instruction manual		Double insulated
	Wear eye protection		Wear hearing protection
	Wear eye, ear & breathing protection		Wear gloves
	Keep hands away from blade		Wear breathing protection

Changing The Blade

WARNING! NEVER USE A BLADE THAT IS TOO THICK. NEVER USE A BLADE THAT IS LARGER THAN THE STATED CAPACITY OF THE MITRE SAW. IT MIGHT COME INTO CONTACT WITH THE BLADE GUARD & RISK PERSONAL INJURY OR DAMAGE TO THE MITRE SAW. THIS WILL NOT BE COVERED UNDER WARRANTY.

WARNING! WEAR GLOVES WHEN PERFORMING A BLADE CHANGE OPERATION.

Only use mitre saw blades with maximum speeds equal to or higher than the maximum speed marked on the tool. Only blades with the following dimensions may be used with this tool.

(Diameter) 254 x (bore) 25.4 x (kerf) 3.0mm

1. Ensure the plug is disconnected from the mains power supply. Ensure the cutting head is raised. If the head lock down pin is locked in place, pull the head lock down pin and gently raise the cutting head.
2. Raise the lower guard out of the way and hold it
3. Using the 5mm Hex Key loosen the guard cover screw until it disengages the blade bolt cover.
4. Swing the blade bolt cover up and out of the way to reveal the bolt head in the centre of the blade.

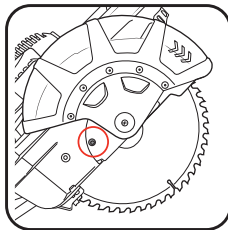

5. Place the 6mm Hex Key onto the blade bolt in the centre of the blade.
6. Depress the spindle lock button. To ensure it engages correctly, rotate the Hex Key until the spindle lock clicks into position.

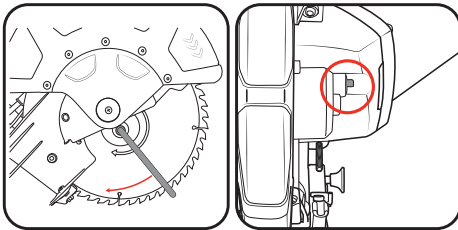

Note: The spindle lock button holds the blade in place when using the 6mm Hex Key to change the blade.

7. Loosen the bolt in the centre of the blade by turning the Hex Key clockwise as the blade bolt is a left hand thread.

Note: Make sure the inner flange stays in place on the spindle.

8. Remove the blade bolt followed by the outer flange. The blade can now be removed by pulling away from the spindle. Put it aside ready to use in the reassembly of the new blade.

Note: Use a rubber mallet to tap the blade off if it is stuck on the tool.

9. Install the new blade over the spindle and onto the inner flange.
10. Replace the outer flange by placing the cupped side of the flange against the blade followed by the blade bolt.
11. Place the 6mm Hex Key provided onto the blade bolt in the centre of the blade.
12. Depress the spindle lock button. To ensure it engages correctly, rotate the Hex Key until the spindle lock clicks into position.
13. Tighten the blade bolt in the centre of the blade by turning the Hex Key anti-clockwise as the blade bolt is a left hand thread.
14. Swing the blade bolt cover back into place and secure it with the guard cover screw. Make sure the lower guard operates smoothly and properly protects from the blade before using the saw.

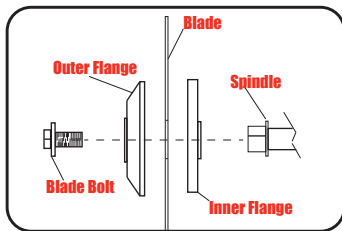

WARNING! ENSURE THAT THE CORRECT BLADE BUSH THAT MAY BE REQUIRED SUITS THE SPINDLE & BLADES THAT ARE FITTED,

WARNING! TO ENSURE THE CORRECT BLADE ROTATION, ALWAYS INSTALL THE BLADE WITH THE TEETH POINTING DOWNWARDS. ENSURE THE ARROW DIRECTION ON THE BLADE CORRESPONDS WITH THE ARROW ON THE UPPER BLADE GUARD.

CARING FOR THE ENVIRONMENT

Power tools that are no longer usable should not be disposed of with household waste but in an environmentally friendly way. Please recycle where facilities exist. Check with your local council authority for recycling advice.

Recycling packaging reduces the need for landfill and raw materials. Reuse of recycled material decreases pollution in the environment. Please recycle packaging where facilities exist. Check with your local council authority for recycling advice.

SPARE PARTS

Spare parts can be ordered from the Special Orders Desk at your local Bunnings Warehouse.

For further information, or any parts not listed here, visit www.ozito.com.au or contact Ozito Customer Service:

Australia 1800 069 486

New Zealand 0508 069 486

E-mail: enquiries@ozito.com.au

ELECTRICAL SAFETY

WARNING! When using mains-powered tools, basic safety precautions, including the following, should always be followed to reduce risk of fire, electric shock, personal injury and material damage. Read the whole manual carefully and make sure you know how to switch the tool off in an emergency, before operating the tool.

Save these instructions and other documents supplied with this tool for future reference.

This tool has been designed for 230V and 240V only. Always check that the power supply corresponds to the voltage on the rating plate. A power source with a voltage greater than that specified for the tool can result in serious injury to the user, as well as damage to the tool. If in doubt, do not plug in the tool. Using a power source with a voltage less than the nameplate rating is harmful to the motor.

Note: The supply of 230V and 240V on Ozito tools are interchangeable for Australia and New Zealand. This tool is double insulated; therefore no earth wire is required.

Note: Double insulation does not take the place of normal safety precautions when operating this tool. The insulation system is for added protection against injury resulting from a possible electrical insulation failure within the tool.

Using an Extension Lead

Always use an approved extension lead suitable for the power input of this tool. Before use, inspect the extension lead for signs of damage, wear and ageing. Replace the extension lead if damaged or defective.

When using an extension lead on a reel, always unwind the lead completely. Use of an extension lead not suitable for the power input of the tool or which is damaged or defective may result in a risk of fire and electric shock.

The power supply for this product should be protected by a residual current device (rated at 30mA or less). A residual current device reduces the risk of electric shock.

GENERAL POWER TOOL SAFETY WARNINGS

 **WARNING!** Read all safety warnings and all instructions. Failure to follow the warnings and instructions may result in electric shock, fire and/or serious injury. The term "power tool" in the warnings refers to your mains-operated (corded) power tool or battery-operated (cordless) power tool.

1. Work area safety

- a. **Keep work area clean and well lit.** Cluttered or dark areas invite accidents.
- b. **Do not operate power tools in explosive atmospheres, such as in the presence of flammable liquids, gases or dust.** Power tools create sparks which may ignite the dust or fumes.
- c. **Keep children and bystanders away while operating a power tool.** Distractions can cause you to lose control.

2. Electrical safety

- a. **Power tool plugs must match the outlet. Never modify the plug in any way. Do not use any adapter plugs with earthed (grounded) power tools.** Unmodified plugs and matching outlets will reduce risk of electric shock.
- b. **Avoid body contact with earthed or grounded surfaces, such as pipes, radiators, ranges and refrigerators.** There is an increased risk of electric shock if your body is earthed or grounded.
- c. **Do not expose power tools to rain or wet conditions.** Water entering a power tool will increase the risk of electric shock.
- d. **Do not abuse the cord. Never use the cord for carrying, pulling or unplugging the power tool. Keep cord away from heat, oil, sharp edges or moving parts.** Damaged or entangled cords increase the risk of electric shock.
- e. **When operating a power tool outdoors, use an extension cord suitable for outdoor use.** Use of a cord suitable for outdoor use reduces the risk of electric shock.
- f. **If operating a power tool in a damp location is unavoidable, use a residual current device (RCD) protected supply.** Use of an RCD reduces the risk of electric shock.

3. Personal safety

- a. **Stay alert, watch what you are doing and use common sense when operating a power tool. Do not use a power tool while you are tired or under the influence of drugs, alcohol or medication.** A moment of inattention while operating power tools may result in serious personal injury.
- b. **Use personal protective equipment. Always wear eye protection.** Protective equipment such as dust mask, non-skid safety shoes, hard hat, or hearing protection used for appropriate conditions will reduce personal injuries.
- c. **Prevent unintentional starting. Ensure the switch is in the off-position before connecting to power source and/or battery pack, picking up or carrying the tool.** Carrying power tools with your finger on the switch or energising power tools that have the switch on invites accidents.
- d. **Remove any adjusting key or wrench before turning the power tool on.** A wrench or a key left attached to a

rotating part of the power tool may result in personal injury.

- e. **Do not overreach. Keep proper footing and balance at all times.** This enables better control of the power tool in unexpected situations.
 - f. **Drive properly. Do not wear loose clothing or jewellery. Keep your hair, clothing and gloves away from moving parts.** Loose clothes, jewellery or long hair can be caught in moving parts.
 - g. **If devices are provided for the connection of dust extraction and collection facilities, ensure these are connected and properly used.** Use of dust collection can reduce dust-related hazards.
 - h. **Do not let familiarity gained from frequent use of tools allow you to become complacent and ignore tool safety principles.** A careless action can cause severe injury within a fraction of a second.
- ## 4. Power tool use and care
- a. **Do not force the power tool. Use the correct power tool for your application.** The correct power tool will do the job better and safer at the rate for which it was designed.
 - b. **Do not use the power tool if the switch does not turn it on and off.** Any power tool that cannot be controlled with the switch is dangerous and must be repaired.
 - c. **Disconnect the plug from the power source and/or the battery pack from the power tool before making any adjustments, changing accessories, or storing power tools.** Such preventive safety measures reduce the risk of starting the power tool accidentally.
 - d. **Store idle power tools out of the reach of children and do not allow persons unfamiliar with the power tool or these instructions to operate the power tool.** Power tools are dangerous in the hands of untrained users.
 - e. **Maintain power tools.** Check for misalignment or binding of moving parts, breakage of parts and any other condition that may affect the power tool's operation. If damaged, have the power tool repaired before use. Many accidents are caused by poorly maintained power tools.
 - f. **Keep cutting tools sharp and clean.** Properly maintained cutting tools with sharp cutting edges are less likely to bind and are easier to control.
 - g. **Use the power tool, accessories and tool bits etc. in accordance with these instructions, taking into account the working conditions and the work to be performed.** Use of the power tool for operations different from those intended could result in a hazardous situation.
 - h. **Keep handles and grasping surfaces dry, clean and free from oil and grease.** Slippery handles and grasping surfaces do not allow for safe handling and control of the tool in unexpected situations.
- ## 5. Service
- a. **Have your power tool serviced by a qualified repair person using only identical replacement parts.** This will ensure that the safety of the power tool is maintained.

MITRE SAW SAFETY WARNINGS

 **WARNING!** The appliance is not to be used by persons (including children) with reduced physical, sensory or mental capabilities, or lack of experience and knowledge, unless they have been given supervision or instruction. Young children should be supervised to ensure that they do not play with the appliance.

- Mitre saws are intended to cut wood or wood-like products, they cannot be used with abrasive cut-off wheels for cutting ferrous materials such as bars, rods studs, etc. Abrasive dust causes moving parts such as the lower guard to jam. Sparks from abrasive cutting will burn the lower guard, the kerf insert and other plastic parts.
- Use clamps to support the workpiece whenever possible. If supporting the workpiece by hand, you must always keep your hand at least 100mm from either side of the saw blade. Do not use this saw to cut pieces that are too small to be securely clamped or held by hand. If your hand is placed too close to the saw blade, there is an increased risk of injury from blade contact.
- The workpiece must be stationary and clamped or held against both the fence and the table. Do not feed the workpiece into the blade or cut "freehand" in any way. Unrestrained or moving workpieces could be thrown at high speeds, causing injury.
- Push the saw through the workpiece. Do not pull the saw through the workpiece. TO make a cut, raise the saw head and pull it out over the workpiece without cutting, start the motor, press the saw head down and push the saw through the workpiece. Cutting on the pull stroke is likely to cause the saw blade to climb on top of the workpiece and violently throw the blade assembly towards the operator.
- Never cross your hand over the intended line of cutting either in front or behind the saw blade. Supporting the workpiece "cross handed" i.e. holding the workpiece to the right of the saw blade with your left hand or vice versa is very dangerous.
- Do not reach behind the fence with either hand closer than 100 mm from either side of the saw blade, to remove wood scraps, or for any other reason while the blade is spinning. The proximity of the spinning saw blade to your hand may not be obvious and you may be seriously injured.
- Inspect your workpiece before cutting. If the workpiece is bowed or warped, clamp it with the outside bowed face toward the fence. Always make certain that there is no gap between the workpiece, fence and table along the line of the cut. Bent or warped workpieces can twist or shift and may cause binding on the spinning saw blade while cutting. There should be no nails or foreign objects in the workpiece.
- Do not use the saw until the table is clear of all tools, wood scraps, etc., except for the workpiece. Small debris or loose pieces of wood or other objects that contact the revolving blade can be thrown with high speed.
- Cut only one workpiece at a time. Stacked multiple workpieces cannot be adequately clamped or braced and may bind on the blade or shift during cutting.
- Ensure the mitre saw is mounted or placed on a level, firm work surface before use. A level and firm work surface reduces the risk of the mitre saw becoming unstable.
- Plan your work. Every time you change the bevel or mitre angle setting, make sure the adjustable fence is set correctly to support the workpiece and will not interfere with the blade or the guarding system. Without turning the tool "ON" and with no workpiece on the table, move the saw blade through a complete simulated cut to assure there will be no interference or danger of cutting the fence.
- Provide adequate support such as table extensions, saw horse, etc. for a workpiece that is wider or longer than the table top. Workpieces longer or wider than the mitre saw table can tip if not securely supported. If the cut-off piece or workpiece tips, it can lift the lower guard or be thrown by the spinning blade.
- Do not use another person as a substitute for a table extension or as additional support. Unstable support for the workpiece can cause the blade to bind or the workpiece to shift during the cutting operation pulling you and the helper into the spinning blade.
- The cut-off piece must not be jammed or pressed by any means against the spinning saw blade. If confined, i.e. using length stops, the cut-off piece could get wedged against the blade and thrown violently.
- Always use a clamp or fixture designed to properly support round material such as rods or tubing. Rods have a tendency to roll while being cut, causing the blade to "bite" and pull the work with your hand into the table.
- Let the blade reach full speed before contacting the workpiece. This will reduce the risk of the workpiece being thrown.
- If the workpiece or blade becomes jammed, turn the mitre saw off. Wait for all moving parts to stop and

disconnect the plug from the power source and/or remove the battery pack. Then work to free the jammed material. Continued sawing with a jammed workpiece could cause loss of control or damage to the mitre saw.

- After finishing the cut, release the switch, hold the saw head down and wait for the blade to stop before removing the cut-off piece. Reaching with your hand near the coasting blade is dangerous.
- Hold the handle firmly when making an incomplete cut or when releasing the switch before the saw head is completely in the down position. The braking action of the saw may cause the saw head to be suddenly pulled downward, causing a risk of injury.
- Always remove the plug from the mains socket before making any adjustments or maintenance, including changing the blade.
- When operating the saw, use safety equipment including safety goggles or shield, ear protection, dust mask and protective clothing including safety gloves. Keep hands away from moving parts.
- Ensure that there is adequate general or localised lighting. Never saw near combustible liquids or gases. Keep the floor area around the machine level, well maintained and free of loose materials.
- Do not use the saw unless the guards are in place. Periodically check that all nuts, bolts and other fixings are properly tightened.
- Never use a cracked or distorted saw blade. Do not use blades of High Speed Steel (HSS blades).
- If the table insert is damaged or worn, have it replaced by a power tool repairer.
- Do not store materials or equipment above a machine in such a way that they could fall into it.
- Always hold the saw on parts that are insulated. If you accidentally cut into hidden wiring or the saw's own cable, the metal parts of the saw will become "live". Switch off at the mains and remove the plug immediately.
- Do not lock the movable guard in the open position and always ensure that it is working properly, freely rotating and returning to fully cover the teeth of the blade. Ensure that the arm is properly secure when beveling.
- Connect the saw to a dust collection device and ensure that it is operating properly. As the operator of the saw, please make sure that you understand factors that influence exposure to dust, including the type of material to be cut, the importance of local extraction and the proper adjustment of hoods/baffles/chutes of your dust extraction system. We recommend that you always wear a dust mask when operating this saw.
- When cutting long pieces which extend well over the table width, ensure that the ends are adequately supported at the same height as the saw table top. Supports should be positioned in such a way to ensure that the workpiece does not fall to the ground once the cut has been made. A number of supports at regular intervals may be required if the workpiece is extremely long.
- Do not force the tool, allow the blade to cut the workpiece. Failure to do so may overheat the blade, reducing the life of the product. Push the saw through the workpiece. Do not pull the saw through the workpiece.
- Do not remove any cut-offs from the cutting area until the mitre saw head is in the full upright position, the blade guard is fully enclosing the blade and the blade has come to a rest or complete stop. Never use your hands to remove sawdust, chips or waste close by the blade.
- Do not slow or stop a blade with a piece of wood. Let the blade come to rest without assistance. If you are interrupted when operating the saw, complete the process and switch off before looking up.
- Take additional care when trenching (slotting). Hold the handle firmly when making an incomplete cut or when releasing the switch before the saw head is completely in the down position. The braking action of the saw may cause the saw head to be suddenly pulled downward, causing a risk of injury.
- Note the direction of rotation of the motor and the blade. Use correctly sharpened saw blades and observe the maximum speed marked on the blade. Only use saw blades with maximum speeds equal to or higher than the maximum speed marked on the tool. Only use (diameter) 254 x (bore) 25.4 x (kerf) 3.0mm blades with this saw.
- This saw is only meant for cutting timber and plastics. Do not use the saw to cut metal or masonry. Do not use this saw to cut firewood. When cutting plastics the heat generated by the saw blade tips may melt the plastic. Always do a test cut on scrap material beforehand. Avoid cutting nails. Inspect the workpiece and remove all nails and other foreign objects before operating the saw.
- Periodically wipe the laser lens gently with a dry soft cloth. Ensure the unit is switched off before doing so. Do not stare directly into the laser. Always check the laser on a workpiece.
- The mitre saw can be safely carried by the carrying handle but only once it has been removed from the mains power and secured in the locked down position. Saw blades shall be carried in a holder wherever possible.