

KIOS Garden Planter



600L x 270W x 450Hmm | Multi-Colour

Important: Before you commence assembling this unit open carton and lay all parts on a clear floor space and check all the parts against the parts list included in the instructions. This will ensure that you become familiar with each part and make assembling faster.

You will need the following: Cordless screwdriver with a Phillips-head bit or a standard Phillips-head screwdriver and a shifter.

SAFETY TIP:

When assembling or installing this product wear protective gloves and eyewear.

Part list:

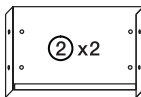
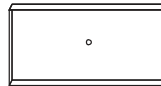
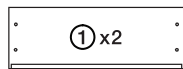

④ x4

⑦ x16

⑧ x1

Step 1:

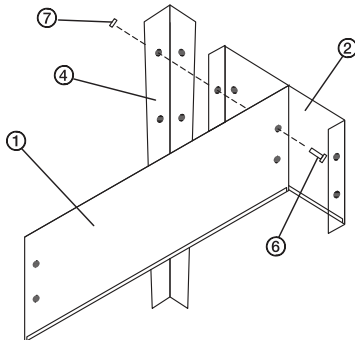

Step 2:

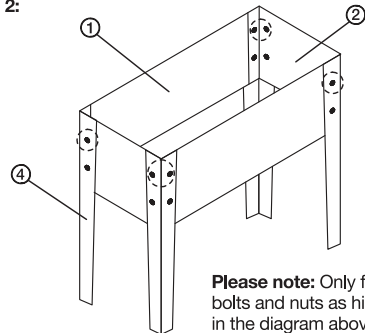

Please note: Only fix the top bolts and nuts as highlighted in the diagram above.

Step 3:

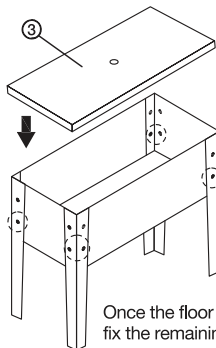

Once the floor (part 3) is in place, fix the remaining bolts and nuts.

Step 4:

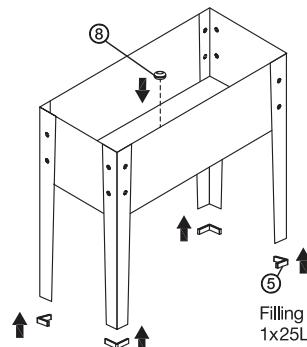

Filling suggestion:
1x25L bags of soil.

WARRANTY CONDITIONS

Any claim under this warranty must be made within 1 year of the date of purchase of the product. To make a claim under this warranty, take the product (with proof of purchase) to any Bunnings store (see www.bunnings.com.au for store locations). Pinnacle Hardware bears reasonable, direct expenses of claiming under the warranty. You may submit details and proof of purchase to our support centre for consideration. The warranty covers manufacturer defects in materials, workmanship and finish under normal use. This warranty is provided in addition to other rights and remedies you may have under law. Our goods come with guarantees that cannot be excluded under the Australian consumer law or Consumer Guarantees Act 1993 (NZ). You are entitled to a replacement or refund for a major failure and compensation for any other reasonably foreseeable loss or damage. You are also entitled to have the goods repaired or replaced if the goods fail to be of acceptable quality and the failure does not amount to a major failure. This warranty excludes damage resulting from product misuse or product neglect. The warranty covers domestic use only and does not apply to commercial applications. This warranty is given by Pinnacle Hardware, ABN 87 614 496 196, 28 Hudson Court, Keysborough Vic 3173, 1800 349 776, Email: support@pinnacle.net.au. New Zealand customers please contact HARCO (Harkness & Young Ltd), 09 27 64071, Email: sales@harknessyoung.co.nz. 'Pinnacle' is a trademark. © Pinnacle Hardware, Suitable for model number GBE003.