



MIMOSA®

Cordoba Charcoal 1 Seater Lounge
Installation Guide

The first part of the document discusses the importance of maintaining accurate records of all transactions. It emphasizes that every entry, no matter how small, should be recorded to ensure the integrity of the financial data. This includes not only sales and purchases but also expenses and income. The document provides a detailed explanation of how to categorize these transactions and how to use a double-entry system to ensure that the books balance. It also discusses the importance of regular reconciliations to catch any errors early on.

The second part of the document focuses on the practical aspects of bookkeeping. It provides a step-by-step guide to setting up a chart of accounts, which is the foundation of the accounting system. It also discusses how to use journals and ledgers to record transactions and how to prepare financial statements. The document includes several examples of journal entries and T-accounts to illustrate the concepts. It also discusses the importance of maintaining a clear and organized system of records, including the use of proper filing and labeling techniques.

The third part of the document discusses the importance of internal controls in a business. It explains how internal controls can help to prevent fraud and errors, and how they can be used to improve the efficiency of the business. It provides a list of common internal controls and discusses how to implement them in a business. It also discusses the importance of separating duties and having a system of checks and balances.

The fourth part of the document discusses the importance of tax compliance. It explains how to calculate and pay taxes, and how to keep records of all tax-related transactions. It also discusses the importance of staying up-to-date on tax laws and regulations, and how to seek professional advice when needed. The document includes a list of common tax deductions and credits, and discusses how to claim them.

The fifth part of the document discusses the importance of financial analysis. It explains how to use financial statements to evaluate the performance of the business, and how to use ratios and other tools to analyze the data. It also discusses the importance of budgeting and forecasting, and how to use these tools to plan for the future. The document includes several examples of financial ratios and discusses how to interpret them.

Cordoba Charcoal 1 Seater Lounge

POWDER COATED ALUMINIUM FRAME

Polyester Padded Cushions- Grey

ITEM NO. : 0583684

4.

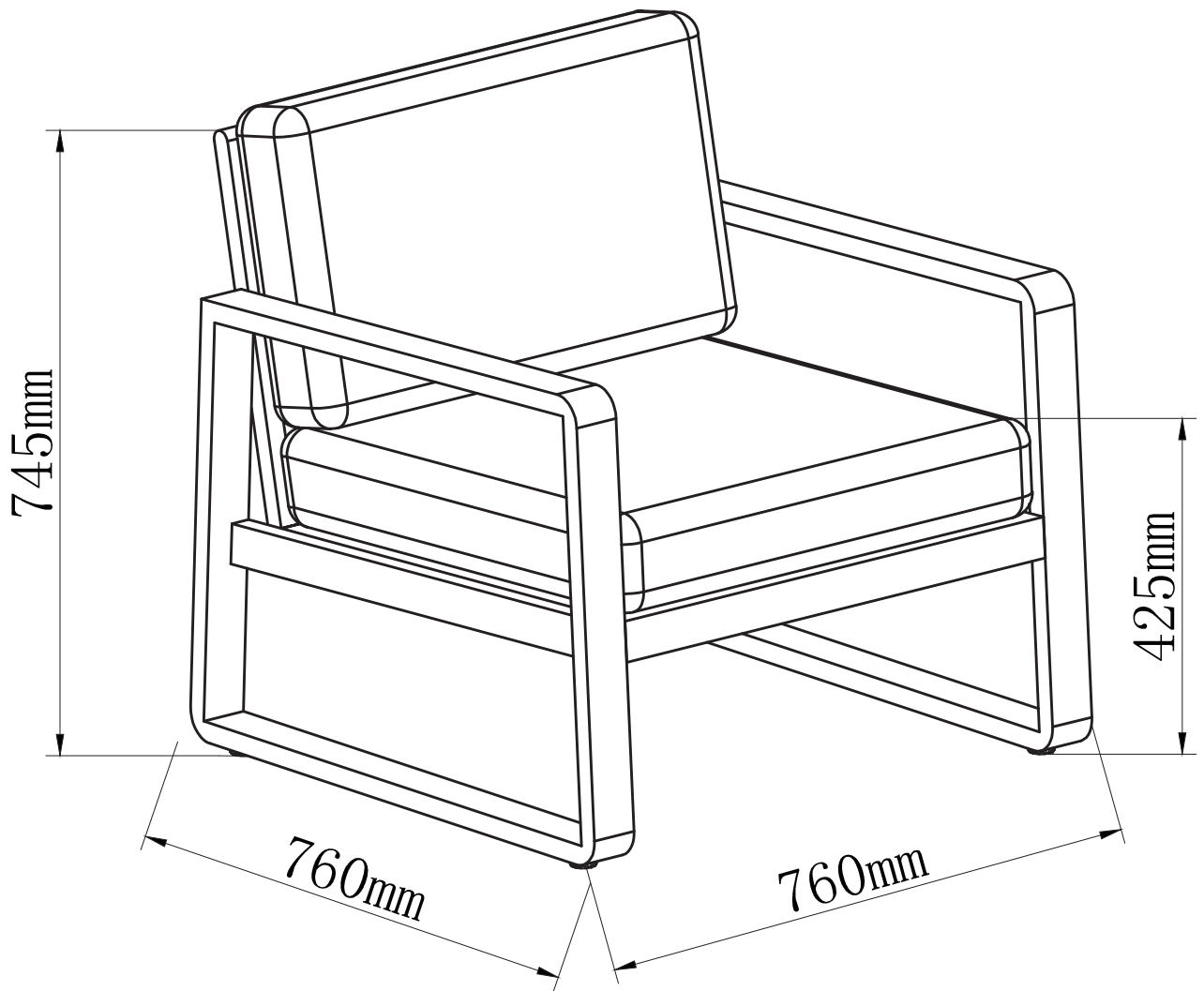



**Please carefully read the below warnings and instructions.
Save the instructions for future reference.**





- Please carefully read all instructions before assembly and use.
- Please separate and identify all parts, ensuring that you have all parts listed.
- Assembly to be carried out by a competent adult.
- During assembly children should be kept away from the product due to possible risk of injury, small parts, and sharp fittings.
- Do NOT use power tools to assemble the product.
- Don't tight all the bolts before the product is fully assembled. Be careful not to over tighten the nuts during assembly.
- Please check the fixings are all tight monthly.

Recommendation



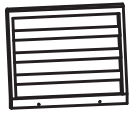
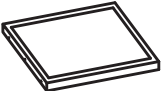



- It would be useful to ask someone to help you assemble the product.
- Retain these instructions for future reference.
- This product is not suitable for extreme weather conditions. Do NOT use in extreme weather condition such as thunderstorm, hailstone, heavy rain, high wind or heavy snow, etc. Warranty claims due to weather events won't be taken into account.
- This piece of furniture has been produced under the best possible conditions and care. However we advise you during constructing or breaking down of this piece of furniture to be aware of sharp metal.
- This product is designed for occasional use only. Do not use as a permanent structure. If no use for long time, dismantle and store safely to prevent any damage occurring.
- You must take into account that fabric may be discolored under the exposure of sunshine. This change is a natural cause, and it is not a factor for claim. It is recommended to replace the fabric every 1 or 2 years.
- To extend the life of your cushion, product should be stored in a dry and ventilated place when not in use and especially over the winter months or during rainy condition. If this is not possible, we advise you to always use a protective waterproof cover when not using the furniture.
- The maximum weight / load of this product is 120kg.
- Wipe clean with damp cloth only using detergent & lukewarm water.

6.

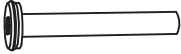
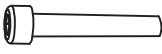
Parts List:

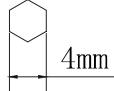
Part No.	Pictures	Description	QTY
A	 A rectangular frame with horizontal slats, representing the backrest structure.	Back frame	1
B	 A simple rectangular frame representing the seat base.	Seat frame	1
C	 A rectangular frame with a horizontal bar across the middle, representing the left armrest.	Left Armrest	1
D	 A rectangular frame with a horizontal bar across the middle, representing the right armrest.	Right Armrest	1
E	 A rectangular cushion with a slightly raised edge, representing the backrest padding.	Back cushion	1
F	 A rectangular cushion with a slightly raised edge, representing the seat padding.	Seat cushion	1

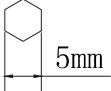
Hardware Kit:

Part No.	Pictures	Description	QTY
G		Bolt M6 x 42 mm	8
H		Bolt M6 x 35 mm	2
J		Washer ø16x6.5x2 mm	8
K	 	Allen key A	1
L	 	Allen key B	1
M		Cap	8



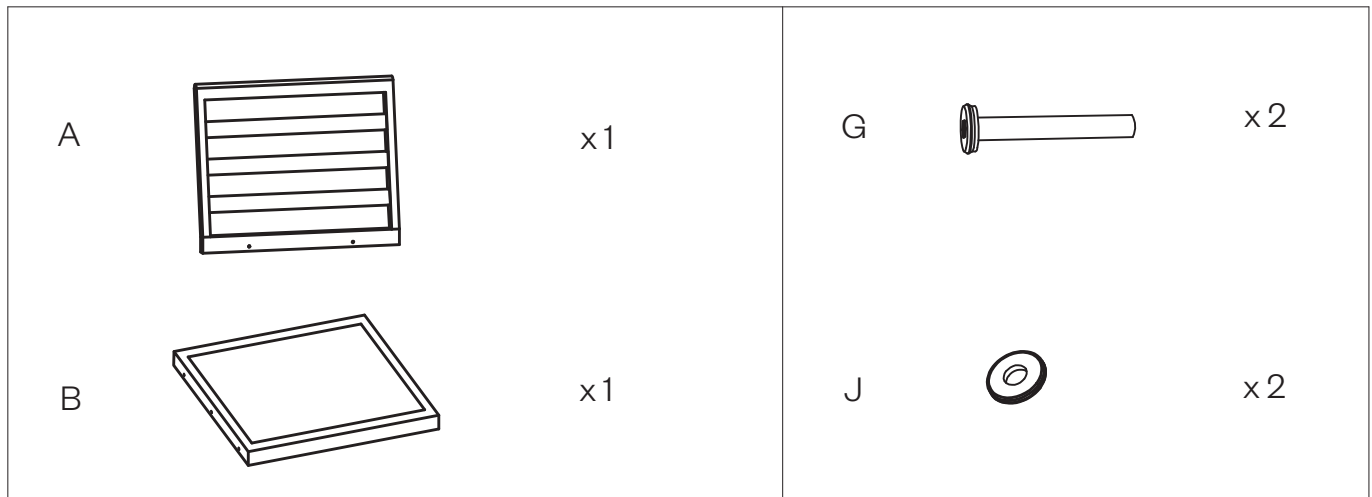



8.

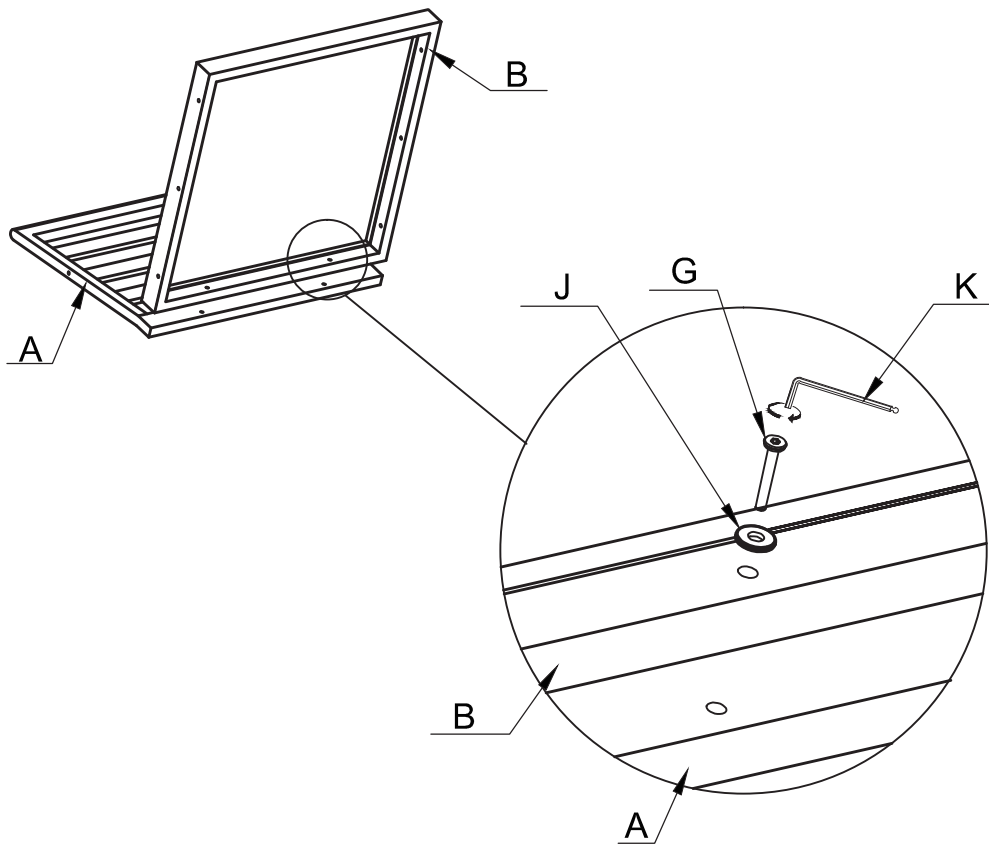

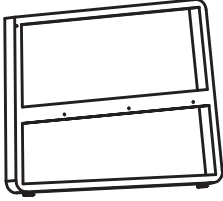
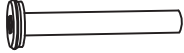
Step 1:

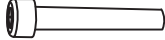
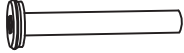
Fix the seat frame (B) to the back frame (A) with bolts (G) and washers (J).
Once all bolts are in position tighten securely using Allen Key (K).

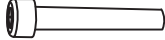
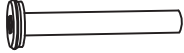

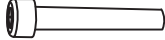
<p>C</p>  <p>x1</p>	<table><tr><td>G</td><td></td><td>x3</td></tr><tr><td>J</td><td></td><td>x3</td></tr><tr><td>H</td><td></td><td>x1</td></tr></table>	G		x3	J		x3	H		x1
G		x3								
J		x3								
H		x1								

Step 2:





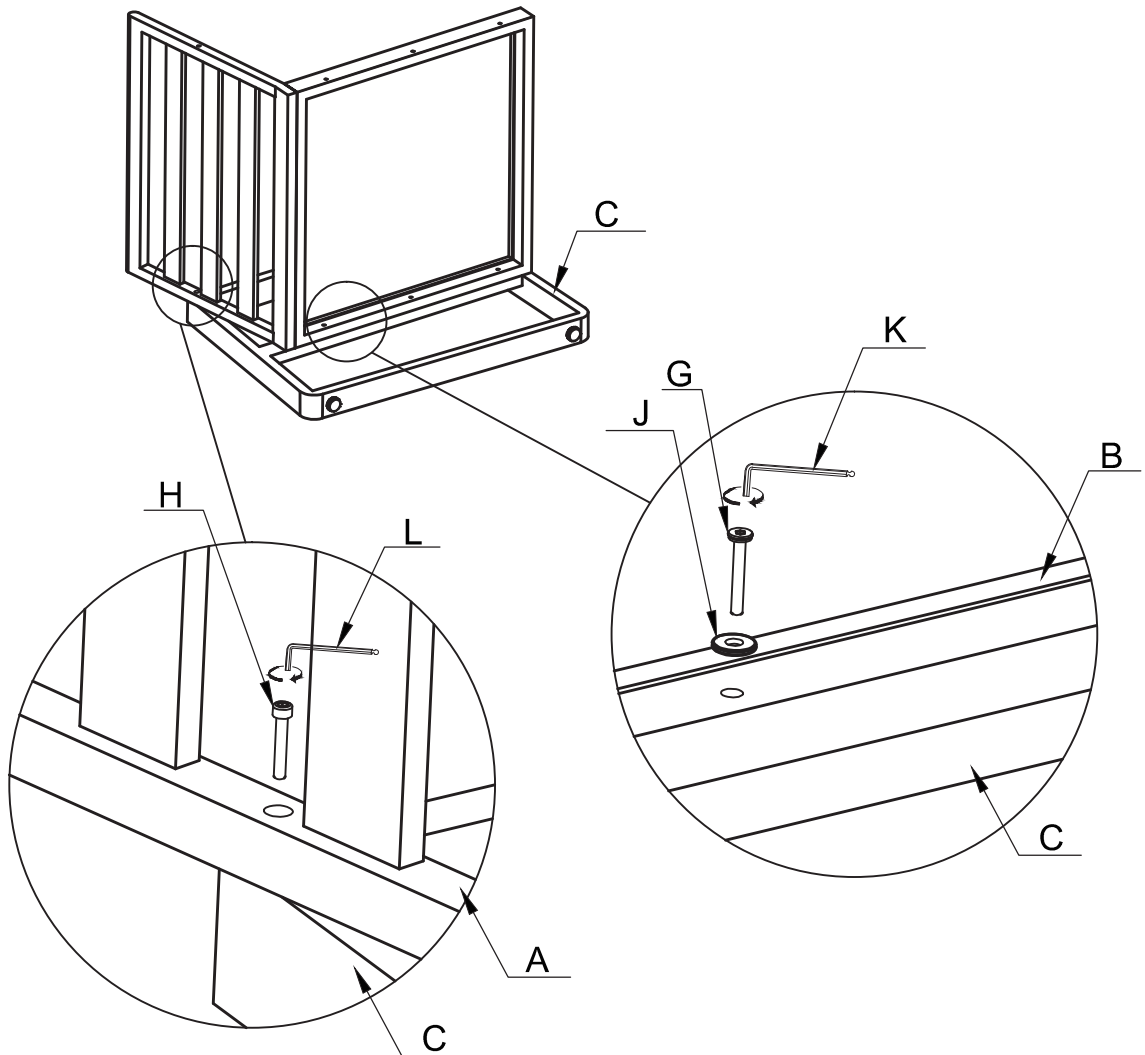

Fix the seat frame (B) to left armrest (C) with bolts (G) and washers (J).

Fix the back frame (A) to left armrest (C) with bolt (H).

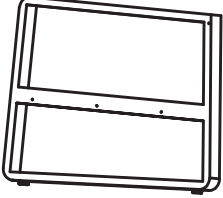
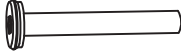
Once all bolts are in position, tighten securely bolts (G) using Allen Key (K), tighten securely bolt (H) using Allen Key (L).

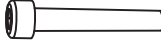
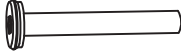

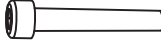
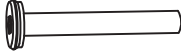
10.

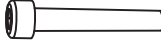
<p>D</p>  <p>x1</p>	<table><tr><td>G</td><td></td><td>x3</td></tr><tr><td>J</td><td></td><td>x3</td></tr><tr><td>H</td><td></td><td>x1</td></tr></table>	G		x3	J		x3	H		x1
G		x3								
J		x3								
H		x1								

Step 3:

Fix the seat frame (B) to right armrest (D) with bolts (G) and washers (J).

Fix the back frame (A) to right armrest (D) with bolt (H).

Once all bolts are in position, tighten securely bolts (G) using Allen Key (K), tighten securely bolt (H) using Allen Key (L).

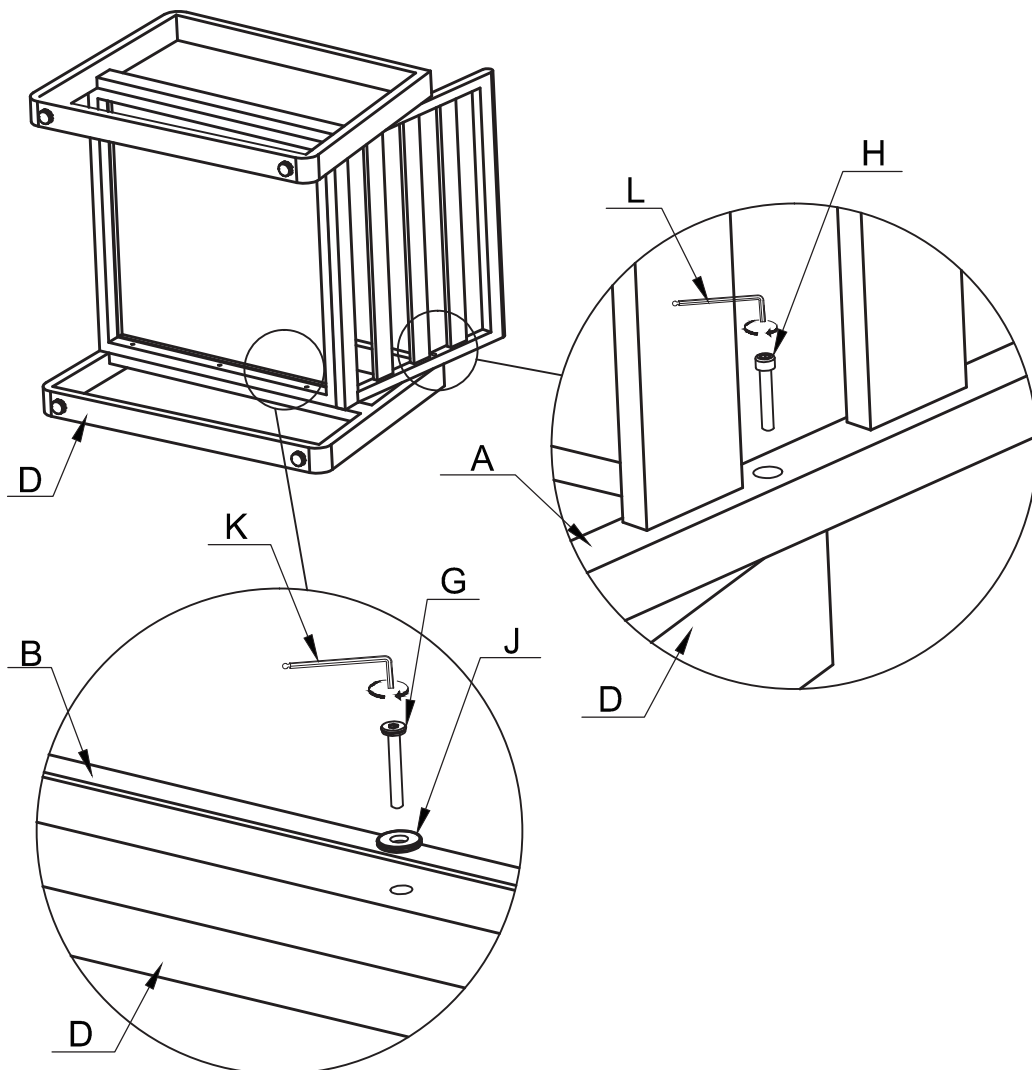

M



x8

Step 4:

Cover the bolts (G) with caps (M).

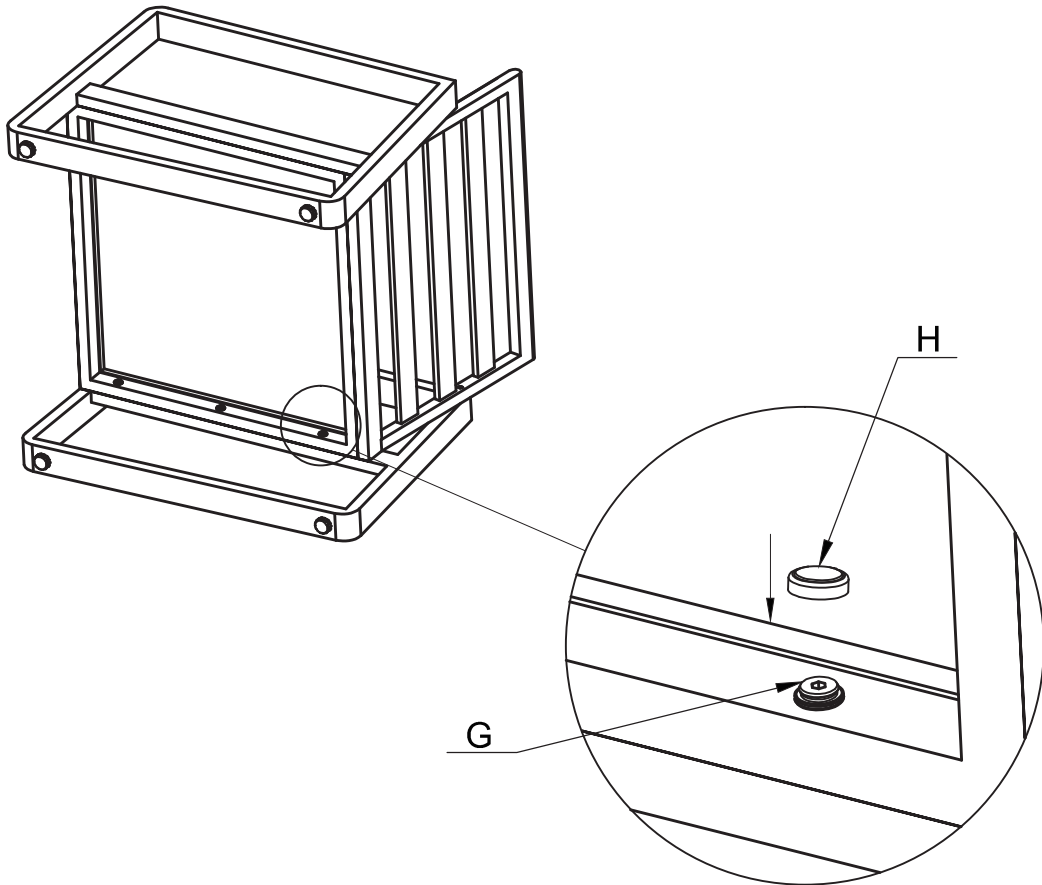

12.

E



x1

F



x1

Step 5:

Put the seat cushion (F) and back cushion (E) on the lounge.

