

## MAINTENANCE

- Keep the vents of the saw clean at all times. If possible, prevent foreign matter from entering the vents.
- After each use, blow air through the saw housing and guard, to ensure it is free from all dust particles which may build up. Build up of dust particles may cause the saw to overheat and fail.
- If the enclosure of the saw requires cleaning, do not use solvents but a moist soft cloth only. Never let any liquid get inside the saw; never immerse any part of the saw into a liquid.



### Carbon Brushes



When the carbon brushes wear out, the saw will spark and/or stop. Discontinue use as soon as this happens. They should be replaced prior to recommencing use of the saw. Carbon brushes are a wearing component of the saw therefore not covered under warranty. Continuing to use the saw when carbon brushes need to be replaced may cause permanent damage to the saw. Carbon brushes will wear out after many uses. When the carbon brushes need to be replaced, take the saw to an electrician or a power tool repairer for a quick and low cost replacement. Always replace both carbon brushes at the same time.

*Note: Ozito Industries will not be responsible for any damage or injuries caused by the repair of the saw by an unauthorised person or by mishandling of the saw.*

## DESCRIPTION OF SYMBOLS

<b>V</b>	Volts	<b>Hz</b>	Hertz
<b>~</b>	Alternating current	<b>W</b>	Watts
<b>/min</b>	Revolutions or reciprocation per minute	<b>∅</b>	No load speed
	Double insulated		Regulator compliance mark
	Warning		

## CARING FOR THE ENVIRONMENT



Power tools that are no longer usable should not be disposed of with household waste but in an environmentally friendly way. Please recycle where facilities exist. Check with your local council authority for recycling advice.



Recycling packaging reduces the need for landfill and raw materials. Reuse of recycled material decreases pollution in the environment. Please recycle packaging where facilities exist. Check with your local council authority for recycling advice.

## TROUBLE SHOOTING

### Circular Saw Tips

Always hold the soft grip handle with one hand and the front handle with the other. Maintain a firm grip and operate the on/off switch with a positive action. Never force the saw. Use light and continuous pressure.

When cutting is interrupted, to resume cutting, depress the lock-off button and squeeze the on/off switch and allow the blade to reach full speed, re-enter the cut slowly and resume cutting.

When cutting across the grain, the fibres of the wood have a tendency to tear and lift. Advancing the saw slowly minimizes this effect. For a finished cut, a cross cut blade or mitre blade is recommended.

### Sparking visible through the housing air vents

A small amount of sparking may be visible through the housing vents. This is normal and does not indicate a problem.

### Excessive sparking visible through the housing air vents and/or the saw failing to operate



May indicate the carbon brushes have worn out and need to be replaced. Carbon brushes should only be replaced by a qualified electrician or power tool repairer.

**WARNING: THE SAW IS RECOMMENDED FOR WOOD CUTTING ONLY AND IS NOT INTENDED TO BE USED WITH ABRASIVE OR MASONRY/WET DIAMOND WHEELS. USING WATER OR OTHER LIQUID COOLANTS WITH THIS MACHINE MAY RESULT IN SHOCK OR ELECTROCUTION.**

**WARNING: AFTER COMPLETING A CUT AND THE ON/OFF SWITCH IS RELEASED, BE AWARE OF THE TIME IT TAKES FOR THE BLADE TO COME TO A COMPLETE STOP. HOLD THE SAW AWAY FROM YOUR BODY UNTIL THE BLADE STOPS COMPLETELY. THIS MAY HELP TO PREVENT SERIOUS INJURY.**

**WARNING: AVOID ACCIDENTAL STARTING BY DISCONNECTING THE TOOL FROM THE POWER SOURCE BEFORE ASSEMBLING OR MAKING ANY ADJUSTMENTS.**

## SPARE PARTS

Blade Bolt	SPCSW7000-01
Outer Flange	SPCSW7000-03
Inner Flange	SPCSW7000-05
Carbon Brush (Pair)	SPCSW7000-44
Brush Holder (Pair)	SPCSW7000-45
Switch	SPCSW7000-51

Spare parts can be ordered from the Special Orders Desk at your local Bunnings Warehouse.

For further information, or any parts not listed here, visit

[www.ozito.com.au](http://www.ozito.com.au) or contact Ozito Customer Service:

Australia 1800 069 486

New Zealand 0508 069 486

E-mail: [enquiries@ozito.com.au](mailto:enquiries@ozito.com.au)

## ELECTRICAL SAFETY



**WARNING!** When using mains-powered tools, basic safety precautions, including the following, should always be followed to reduce risk of fire, electric shock, personal injury and material damage.

Read the whole manual carefully and make sure you know how to switch the tool off in an emergency, before operating the tool.

Save these instructions and other documents supplied with this tool for future reference.

The electric motor has been designed for 230V and 240V only. Always check that the power supply corresponds to the voltage on the rating plate.

Note: The supply of 230V and 240V on Ozito tools are interchangeable for Australia and New Zealand.



This tool is double insulated therefore no earth wire is required.

## GENERAL POWER TOOL SAFETY WARNINGS



**WARNING!** Read all safety warnings and all instructions. Failure to follow the warnings and instructions may result in electric shock, fire and/or serious injury.

Save all warnings and instructions for future reference. The term "power tool" in the warnings refers to your mains-operated (corded) power tool or battery-operated (cordless) power tool.

- Work area safety
  - Keep work area clean and well lit. Cluttered or dark areas invite accidents.
  - Do not operate power tools in explosive atmospheres, such as in the presence of flammable liquids, gases or dust. Power tools create sparks which may ignite the dust or fumes.
  - Keep children and bystanders away while operating a power tool. Distractions can cause you to lose control.
- Electrical safety
  - Power tool plugs must match the outlet. Never modify the plug in any way. Do not use any adapter plugs with earthed (grounded) power tools. Unmodified plugs and matching outlets will reduce risk of electric shock.
  - Avoid body contact with earthed or grounded surfaces, such as pipes, radiators, ranges and refrigerators. There is an increased risk of electric shock if your body is earthed or grounded.
  - Do not expose power tools to rain or wet conditions. Water entering a power tool will increase the risk of electric shock.
  - Do not abuse the cord. Never use the cord for carrying, pulling or unplugging the power tool. Keep cord away from heat, oil, sharp edges or moving parts. Damaged or entangled cords increase the risk of electric shock.
  - When operating a power tool outdoors, use an extension cord suitable for outdoor use. Use of a cord suitable for outdoor use reduces the risk of electric shock.
  - If operating a power tool in a damp location is unavoidable, use a residual current device (RCD) protected supply. Use of an RCD reduces the risk of electric shock.
- Personal safety
  - Stay alert, watch what you are doing and use common sense when operating a power tool. Do not use a power tool while you are tired or under the influence of drugs, alcohol or medication. A moment of inattention while operating power tools may result in serious personal injury.
  - Use personal protective equipment. Always wear eye protection. Protective equipment such as dust mask, non-skid safety shoes, hard hat, or hearing protection used for appropriate conditions will reduce personal injuries.
  - Prevent unintentional starting. Ensure the switch is in the off-position before connecting to power source and/or battery pack, picking up or carrying the tool. Carrying power tools with your finger on the switch or energising power tools that have the switch on invites accidents.

## CIRCULAR SAW SAFETY WARNINGS



**WARNING!**

Safety instructions for all saws Cutting procedures:

- Keep hands away from cutting area and the blade. Keep your second hand on auxiliary handle, or motor housing. If both hands are holding the saw, they cannot be cut by the blade.
- Do not reach underneath the workpiece. The guard cannot protect you from the blade below the workpiece.
- Adjust the cutting depth to the thickness of the workpiece. Less than a full tooth of the blade teeth should be visible below the workpiece.
- Never hold piece being cut in your hands or across your leg. Secure the workpiece to a stable platform. It is important to support the work properly to minimize body exposure, blade binding, or loss of control.
- Hold power tool by insulated gripping surfaces when performing an operation where the cutting tool may contact hidden wiring or its own cord. Contact with a "live" wire will also make exposed metal parts of the power tool "live" and shock the operator.
- When ripping always use a rip fence or straight edge guide. This improves the accuracy of cut and reduces the chance of blade binding.
- Always use blades with correct size and shape (diamond versus round) of arbour holes. Blades that do not match the mounting hardware of the saw will run eccentrically, causing loss of control.
- Never use damaged or incorrect blade washers or bolts. The blade washers and bolt were specially designed for your saw, for optimum performance and safety of operation.

Further safety instructions for all saws

Causes and operator prevention of kickback:

- Kickback is a sudden reaction to a pinched, bound or misaligned saw blade, causing an uncontrolled saw to lift up and out of the workpiece toward the operator.
- When the blade is pinched or bound tightly by the kerf closing down, the blade stalls and the motor reaction drives the unit rapidly back toward the operator.
- If the blade becomes twisted or misaligned in the cut, the teeth at the back edge of the blade can dig into the top surface of the wood causing the blade to climb out of the kerf and jump back toward the operator.
- Kickback is the result of saw misuse and/or incorrect operating procedures or conditions and can be avoided by taking proper precautions as given below.

- Maintain a firm grip with both hands on the saw and position your arms to resist kickback forces. Position your body to either side of the blade, but not in line with the blade. Kickback could cause the saw to jump backwards, but kickback forces can be controlled by the operator, if proper precautions are taken.

If the supply cord is damaged, it must be replaced by an electrician or a power tool repairer in order to avoid a hazard.

**Note:** Double insulation does not take the place of normal safety precautions when operating this tool. The insulation system is for added protection against injury resulting from a possible electrical insulation failure within the tool.

**Using an Extension Lead**

Always use an approved extension lead suitable for the power input of this tool. Before use, inspect the extension lead for signs of damage, wear and ageing. Replace the extension lead if damaged or defective. When using an extension lead on a reel, always unwind the lead completely. Use of an extension lead not suitable for the power input of the tool or which is damaged or defective may result in a risk of fire and electric shock.

- Remove any adjusting key or wrench before turning the power tool on. A wrench or a key left attached to a rotating part of the power tool may result in personal injury.
  - Do not overreach. Keep proper footing and balance at all times. This enables better control of the power tool in unexpected situations.
  - Dress properly. Do not wear loose clothing or jewellery. Keep your hair, clothing and gloves away from moving parts. Loose clothes, jewellery or long hair can be caught in moving parts.
  - If devices are provided for the connection of dust extraction and collection facilities, ensure these are connected and properly used. Use of dust collection can reduce dust-related hazards.
  - Do not let familiarity gained from frequent use of tools allow you to become complacent and ignore tool safety principles. A careless action can cause severe injury within a fraction of a second.
- Power tool use and care
    - Do not force the power tool. Use the correct power tool for your application. The correct power tool will do the job better and safer at the rate for which it was designed.
    - Do not use the power tool if the switch does not turn it on and off. Any power tool that cannot be controlled with the switch is dangerous and must be repaired.
    - Disconnect the plug from the power source and/or the battery pack from the power tool before making any adjustments, changing accessories, or storing power tools. Such preventive safety measures reduce the risk of starting the power tool accidentally.
    - Store idle power tools out of the reach of children and do not allow persons unfamiliar with the power tool or these instructions to operate the power tool. Power tools are dangerous in the hands of untrained users.
    - Maintain power tools. Check for misalignment or binding of moving parts, breakage of parts and any other condition that may affect the power tool's operation. If damaged, have the power tool repaired before use. Many accidents are caused by poorly maintained power tools.
    - Keep cutting tools sharp and clean. Properly maintained cutting tools with sharp cutting edges are less likely to bind and are easier to control.
    - Use the power tool, accessories and tool bits etc. in accordance with these instructions, taking into account the working conditions and the work to be performed. Use of the power tool for operations different from those intended could result in a hazardous situation.
    - Keep handles and grasping surfaces dry, clean and free from oil and grease. Slippery handles and grasping surfaces do not allow for safe handling and control of the tool in unexpected situations.
  - Service
    - Have your power tool serviced by a qualified repair person using only identical replacement parts. This will ensure that the safety of the power tool is maintained.

- When blade is binding, or when interrupting a cut for any reason, release the trigger and hold the saw motionless in the material until the blade comes to a complete stop. Never attempt to remove the saw from the work or pull the saw backward while the blade is in motion or kickback may occur. Investigate and take corrective actions to eliminate the cause of blade binding.
- When restarting a saw in the workpiece, centre the saw blade in the kerf and check that saw teeth are not engaged into the material. If saw blade is binding, it may walk up or kickback from the workpiece as the saw is restarted.
- Support large panels to minimise the risk of blade pinching and kickback. Large panels tend to sag under their own weight. Supports must be placed under the panel on both sides, near the line of cut and near the edge of the panel.
- Do not use dull or damaged blades. Blunt or improperly set blades produce narrow kerf causing excessive friction, blade binding and kickback.
- Blade depth and bevel adjusting locking levers must be tight and secure before making cut. If blade adjustment shifts while cutting, it may cause binding and kickback.
- Use extra caution when making a "plunge cut" into existing walls or other blind areas. The protruding blade may cut objects that can cause kickback.

Safety instructions for saws with pendulum guard Lower guard function:

- Check lower guard for proper closing before each use. Do not operate the saw if lower guard does not move freely and close instantly. Never clamp or tie the lower guard into the open position. If saw is accidentally dropped, lower guard may be bent. Raise the lower guard with the retracting handle and make sure it moves freely and does not touch the blade or any other part, in all angles and depths of cut.
- Check the operation of the lower guard spring. If the guard and the spring are not operating properly, they must be serviced before use. The lower guard may become sluggish due to, gummy deposits, or a buildup of debris.
- Lower guard may be retracted manually only for special cuts such as "plunge cuts" and "compound cuts." Raise lower guard by retracting handle and as soon as blade enters the material, the lower guard must be released. For all other sawing, the lower guard should operate automatically.
- Always observe that the lower guard is covering the blade before placing saw down on bench or floor. An unprotected, coasting blade will cause the saw to walk backwards, cutting whatever is in its path. Be aware of the time it takes for the blade to stop after switch is released. Do not use the tool with abrasive or masonry/wet diamond wheels. Only use blade diameter(s) in accordance with the markings on the tool.

# ozito

## CIRCULAR SAW

**1300W**

### INSTRUCTION MANUAL

### SPECIFICATIONS

Motor:	1300W
No Load Speed:	4800/min
Blade Diameter:	185mm (7 <sup>1</sup> / <sub>4</sub> "
Blade Bore:	16mm
Depth of Cut:	65mm @ 90° 44mm @ 45°
Weight:	4kg

[ozito.com.au](http://ozito.com.au)

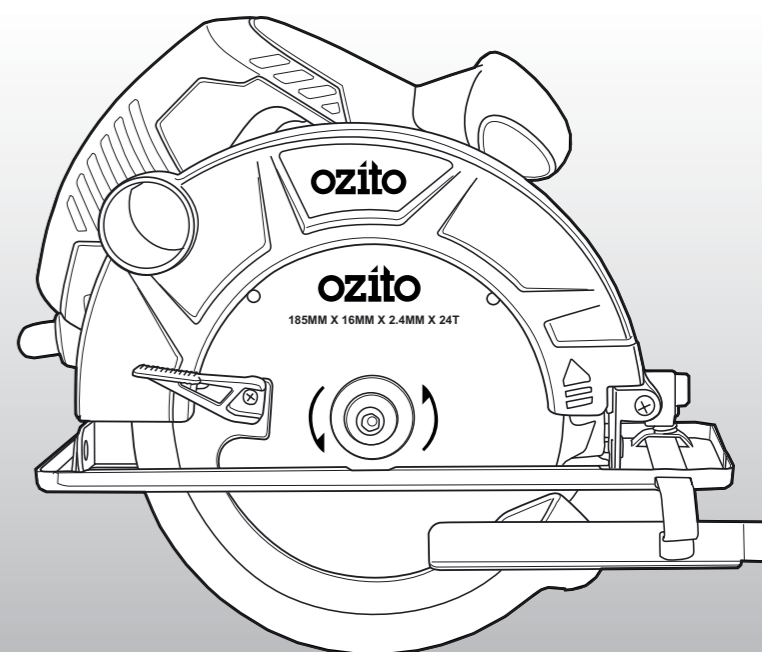

### WHAT'S IN THE BOX

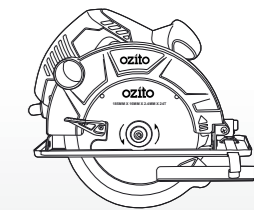

Circular Saw



Rip Fence



Hex Key

**3 YEAR REPLACEMENT WARRANTY**

**CSW-7000**

## WARRANTY

IN ORDER TO MAKE A CLAIM UNDER THIS WARRANTY YOU MUST RETURN THE PRODUCT TO YOUR NEAREST BUNNINGS WAREHOUSE WITH YOUR BUNNINGS REGISTER RECEIPT. PRIOR TO RETURNING YOUR PRODUCT FOR WARRANTY PLEASE TELEPHONE OUR CUSTOMER SERVICE HELPLINE:

**Australia 1800 069 486**

**New Zealand 0508 069 486**

TO ENSURE A SPEEDY RESPONSE PLEASE HAVE THE MODEL NUMBER AND DATE OF PURCHASE AVAILABLE. A CUSTOMER SERVICE REPRESENTATIVE WILL TAKE YOUR CALL AND ANSWER ANY QUESTIONS YOU MAY HAVE RELATING TO THE WARRANTY POLICY OR PROCEDURE.

The benefits provided under this warranty are in addition to other rights and remedies which are available to you at law.

Our goods come with guarantees that cannot be excluded at law. You are entitled to a replacement or refund for a major failure and for compensation for any other reasonably foreseeable loss or damage. You are also entitled to have the goods repaired or replaced if the goods fail to be of acceptable quality and the failure does not amount to a major failure.

Generally you will be responsible for all costs associated with a claim under this warranty, however, where you have suffered any additional direct loss as a result of a defective product you may be able to claim such expenses by contacting our customer service helpline above.

### 3 YEAR REPLACEMENT WARRANTY

Your product is guaranteed for a period of **36 months from the original date of purchase** and is intended for DIY (Do It Yourself) use only. If a product is defective it will be replaced in accordance with the terms of this warranty. Warranty excludes consumable parts.

### WARNING

The following actions will result in the warranty being void.

- If the tool has been operated on a supply voltage other than that specified on the tool.
- If the tool shows signs of damage or defects caused by or resulting from abuse, accidents or alterations.
- Failure to perform maintenance as set out within the instruction manual.
- If the tool is disassembled or tampered with in any way.



# KNOW YOUR PRODUCT

## CIRCULAR SAW

- |                           |                        |
|---------------------------|------------------------|
| 1 Baseplate               | 6 Blade Flange         |
| 2 Dust Extraction Port    | 7 Upper Blade Guard    |
| 3 Lower Blade Guard Lever | 8 Front Handle         |
| 4 Blade                   | 9 Rip Fence            |
| 5 Lower Blade Guard       | 10 Cutting Guide Notch |

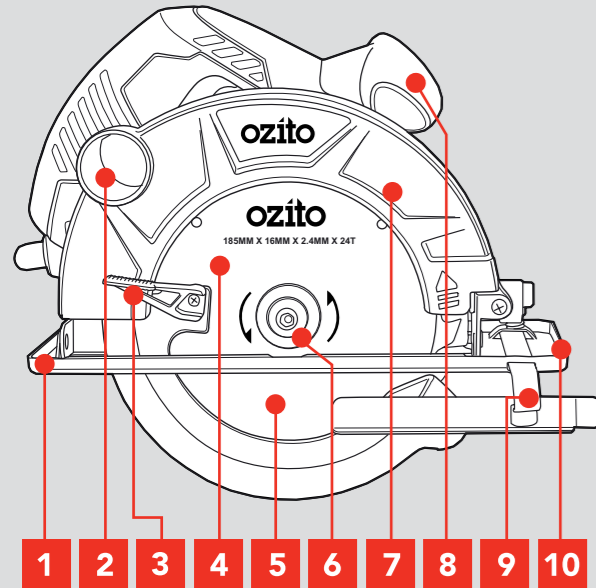

- |                          |                           |
|--------------------------|---------------------------|
| 11 Rip Fence Lock Knob   | 16 Lock Off Button        |
| 12 Bevel Adjustment Knob | 17 Depth Adjustment Scale |
| 13 Bevel Scale           | 18 Depth Adjustment Knob  |
| 14 Spindle Lock Button   | 19 Hex Key                |
| 15 On/Off Switch         |                           |

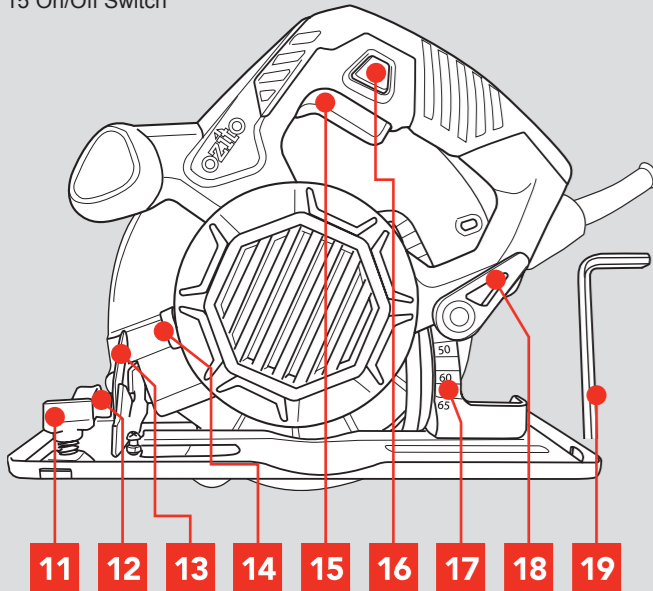

### ONLINE MANUAL

Scan this QR Code with your mobile device to take you to the online manual.



# SETUP & PREPARATION

## 1. DEPTH & BEVEL ADJUSTMENT

Ensure the tool is disconnected from the power supply before performing any of the following operations.

### Depth Adjustment

Depth should be adjusted so that no more than one tooth is protruding through the timber. This helps to minimise splintering.

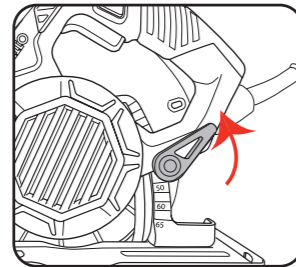

- Loosen the depth adjustment knob.

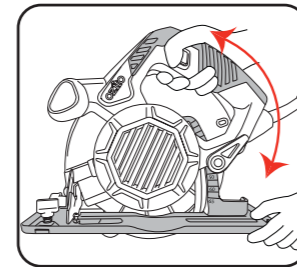

- Hold the baseplate down with one hand. Raise or lower the saw to the desired depth, referring to the scale.

- Tighten depth adjustment knob.

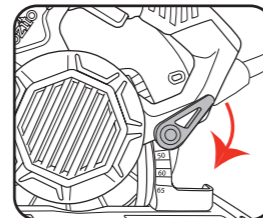

### Bevel Adjustment

- Loosen bevel adjustment knob. Align baseplate to desired angle on bevel scale.

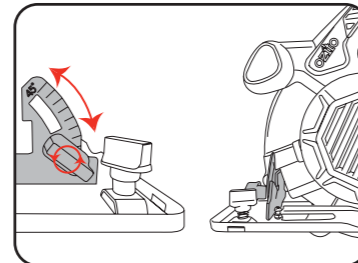

- Tighten bevel adjustment knob.

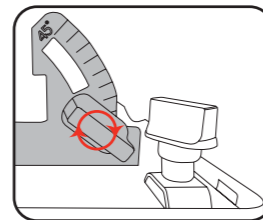

## 2. CUTTING ANGLE CHECK

- Set baseplate to maximum depth of cut.

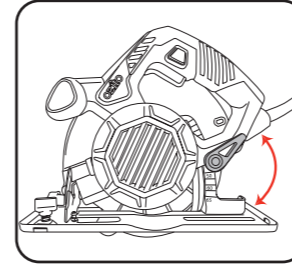

- Loosen bevel adjustment knob. Set to 0° on the scale. Tighten bevel adjustment knob.

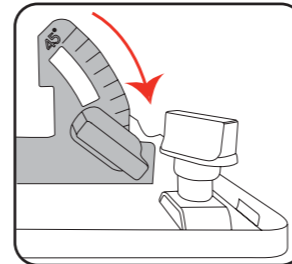

- Confirm the angle between the blade and the baseplate is 90° using a square.

### Cutting Guide Notch

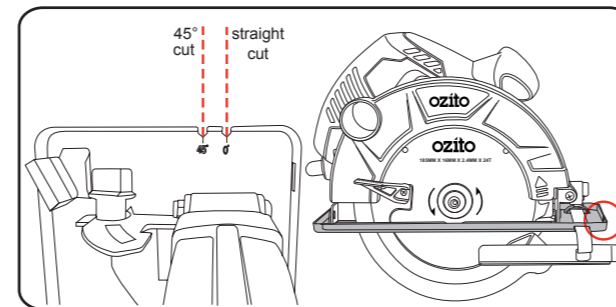

- The cutting guide will give an approximate line of cut. For a straight cut, use the 0° notch. For a 45° cut, use the 45° notch.

# OPERATION

## 3. ON/OFF SWITCH

The tool is recommended for use with a residual current device with a rated residual current of 30mA or less.

- Connect the tool to the mains power supply.
- Securely clamp your workpiece.
- To turn the saw on, depress the lock off switch then the on/off switch.

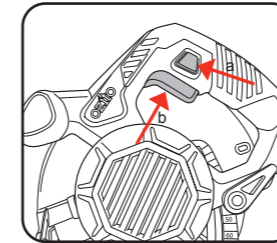

- To stop the saw, release the on/off switch.

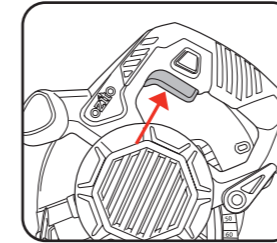

**WARNING:** AFTER USE, HOLD THE SAW AWAY FROM YOUR BODY UNTIL THE BLADE STOPS COMPLETELY. THIS MAY HELP TO PREVENT SERIOUS INJURY.

## 4. CUTTING GUIDE

### Rip Fence

The combination blade provided with your saw is for both cross cuts and rip cuts. Ripping is cutting lengthwise with the grain of the wood. Rip cuts are made easy with the addition of a rip fence.

- To attach rip fence, insert through slots in baseplate.

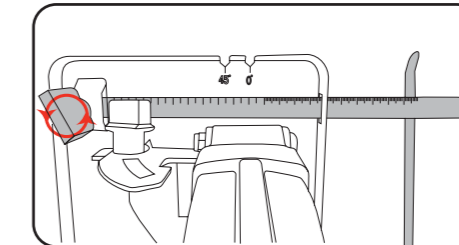

- Set to desired width by aligning the scale with the cutting guide notch.

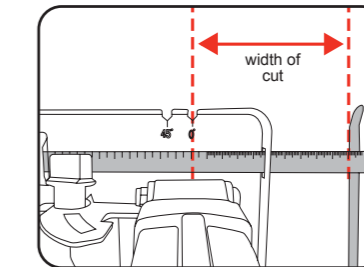

- Tighten rip fence lock knob.

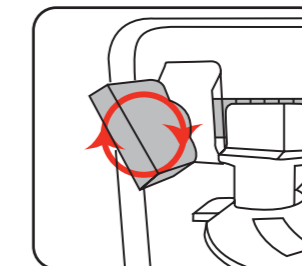

### Rip Board Guide

If the rip fence is not wide enough to allow the desired width of cut, clamp a straight piece of timber to your workpiece and use the right side of the baseplate to guide the saw along the desired path.

- Measure distance between cut line and edge of baseplate.

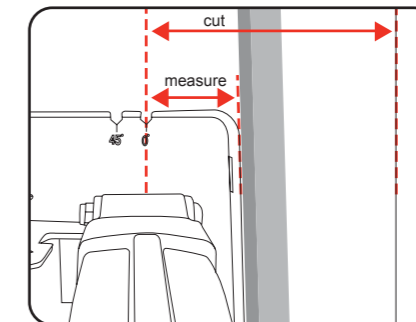

- Clamp board along edge of baseplate to rip desired width.

## 5. BLADE FITMENT

The tool is recommended for wood cutting only and is not recommended for use with abrasive wheels or masonry/diamond cutting wheels. Only use 185mm wood cutting blades.

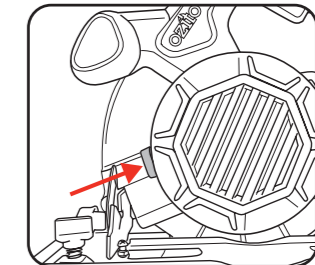

- Press spindle lock button.

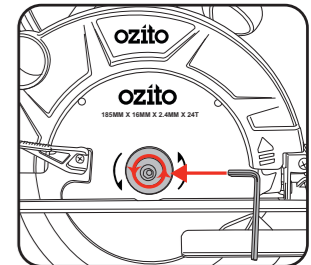

- Use hex key to rotate blade until lock engages. Remove blade bolt and outer blade flange.

- Retract lower blade guard fully.

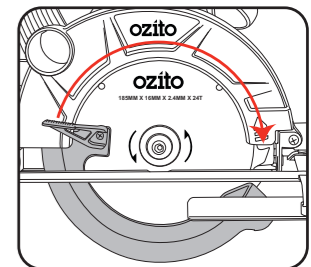

- Remove and replace blade. Ensure arrows on the blade point in the same direction as the arrow on the upper blade guard.

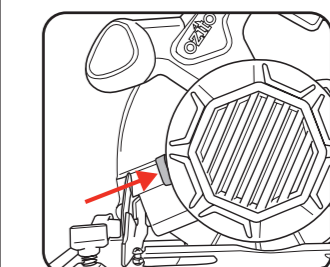
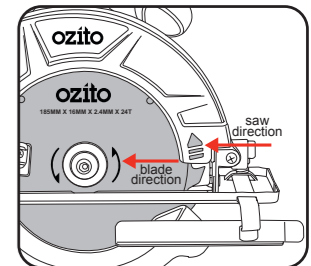

- Fit outer blade flange and blade bolt. Depress spindle lock.

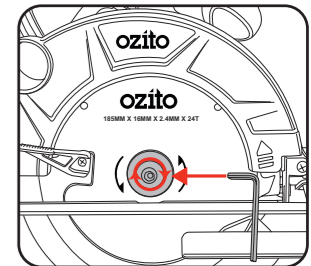

- Tighten blade bolt.

**3** YEAR REPLACEMENT WARRANTY