

RVI18



IMPORTANT!

It is essential that you read the instructions in this manual before assembling, operating, and maintaining the product.
Subject to technical modifications.

Safety, performance, and dependability have been given top priority in the design of your high volume inflator.

INTENDED USE

The high volume inflator is intended for inflating air mattresses, beach balls and similar inflatables. When the deflation port is attached to the nozzle, the product can be used for deflating inflatables. The product can also be used for cleaning work surfaces.

Do not use the product for any other purpose.

GENERAL POWER TOOL SAFETY WARNINGS

⚠ WARNING! Read all safety warnings, instructions, illustrations and specifications provided with this power tool. Failure to follow all instructions listed below may result in electric shock, fire and/or serious injury. **Save all warnings and instructions for future reference.**

The term "power tool" in the warnings refers to your mains-operated (corded) power tool or battery-operated (cordless) power tool.

WORK AREA SAFETY

- **Keep work area clean and well lit.** Cluttered or dark areas invite accidents.
- **Do not operate power tools in explosive atmospheres, such as in**

the presence of flammable liquids, gases or dust. Power tools create sparks which may ignite the dust or fumes.

- **Keep children and bystanders away while operating a power tool.** Distractions can cause you to lose control.

ELECTRICAL SAFETY

- **Power tool plugs must match the outlet. Never modify the plug in any way. Do not use any adapter plugs with earthed(grounded) power tools.** Unmodified plugs and matching outlets will reduce risk of electric shock.
- **Avoid body contact with earthed or grounded surfaces, such as pipes, radiators, ranges and refrigerators.** There is an increased risk of electric shock if your body is earthed or grounded.
- **Do not expose power tools to rain or wet conditions.** Water entering a power tool will increase the risk of electric shock.
- **Do not abuse the cord. Never use the cord for carrying, pulling or unplugging the power tool. Keep cord away from heat, oil, sharp edges or moving parts.** Damaged or entangled cords increase the risk of electric shock.
- **When operating a power tool outdoors, use an extension cord suitable for outdoor use.** Use of a cord suitable for outdoor use reduces the risk of electric shock.
- **If operating a power tool in a damp location is unavoidable, use a residual current device (RCD) protected supply.** Use of an RCD reduces the risk of electric shock.

PERSONAL SAFETY

- **Stay alert, watch what you are doing and use common sense when operating a power tool. Do not use a power tool while you are tired or under the influence of drugs, alcohol or medication.** A moment of inattention while operating power tools may result in serious personal injury.
- **Use personal protective equipment. Always wear eye protection.** Protective equipment such as a dust mask, non-skid safety shoes, hard hat or hearing protection used for appropriate conditions will reduce personal injuries.
- **Prevent unintentional starting. Ensure the switch is in the off-position before connecting to power source and/or battery pack, picking up or carrying the tool.** Carrying power tools with your finger on the switch or energising power tools that have the switch on invites accidents.
- **Remove any adjusting key or wrench before turning the power tool on.** A wrench or a key left attached to a rotating part of the power tool may result in personal injury.
- **Do not overreach. Keep proper footing and balance at all times.** This enables better control of the power tool in unexpected situations.
- **Dress properly. Do not wear loose clothing or jewellery. Keep your hair and clothing away from moving parts.** Loose clothes, jewellery or long hair can be caught in moving parts.
- **If devices are provided for the connection of dust extraction and**

collection facilities, ensure these are connected and properly used. Use of dust collection can reduce dust-related hazards.

- **Do not let familiarity gained from frequent use of tools allow you to become complacent and ignore tool safety principles.** A careless action can cause severe injury within a fraction of a second.

POWER TOOL USE AND CARE

- **Do not force the power tool. Use the correct power tool for your application.** The correct power tool will do the job better and safer at the rate for which it was designed.
- **Do not use the power tool if the switch does not turn it on and off.** Any power tool that cannot be controlled with the switch is dangerous and must be repaired.
- **Disconnect the plug from the power source and/or remove the battery pack, if detachable, from the power tool before making any adjustments, changing accessories, or storing power tools.** Such preventive safety measures reduce the risk of starting the power tool accidentally.
- **Store idle power tools out of the reach of children and do not allow persons unfamiliar with the power tool or these instructions to operate the power tool.** Power tools are dangerous in the hands of untrained users.
- **Maintain power tools and accessories. Check for misalignment or binding of moving parts, breakage of parts and any other condition that may affect the power tool's operation.** If damaged, have the power

tool repaired before use. Many accidents are caused by poorly maintained power tools.

- **Keep cutting tools sharp and clean.** Properly maintained cutting tools with sharp cutting edges are less likely to bind and are easier to control.
- **Use the power tool, accessories and tool bits etc. in accordance with these instructions, taking into account the working conditions and the work to be performed.** Use of the power tool for operations different from those intended could result in a hazardous situation.
- **Keep handles and grasping surfaces dry, clean and free from oil and grease.** Slippery handles and grasping surfaces do not allow for safe handling and control of the tool in unexpected situations.

BATTERY TOOL USE AND CARE

- **Recharge only with the charger specified by the manufacturer.** A charger that is suitable for one type of battery pack may create a risk of fire when used with another battery pack.
- **Use power tools only with specifically designated battery packs.** Use of any other battery packs may create a risk of injury and fire.
- **When battery pack is not in use, keep it away from other metal objects, like paper clips, coins, keys, nails, screws or other small metal objects, that can make a connection from one terminal to another.** Shorting the battery terminals together may cause burns or a fire.
- **Under abusive conditions, liquid may be ejected from the battery; avoid contact. If contact**

accidentally occurs, flush with water. If liquid contacts eyes, additionally seek medical help. Liquid ejected from the battery may cause irritation or burns.

- **Do not use a battery pack or tool that is damaged or modified.** Damaged or modified batteries may exhibit unpredictable behaviour resulting in fire, explosion or risk of injury.
- **Do not expose a battery pack or tool to fire or excessive temperature.** Exposure to fire or temperature above 130°C may cause explosion.
- **Follow all charging instructions and do not charge the battery pack or tool outside the temperature range specified in the instructions.** Charging improperly or at temperatures outside the specified range may damage the battery and increase the risk of fire.

SERVICE

- **Have your power tool serviced by a qualified repair person using only identical replacement parts.** This will ensure that the safety of the power tool is maintained.
- **Never service damaged battery packs.** Service of battery packs should only be performed by the manufacturer or authorized service providers.

INFLATOR SAFETY WARNINGS

- To reduce the risk of electrical shock, do not put the product in water or other liquid. Do not place or store an appliance where it can fall or be pulled into a tub or sink.
- Do not use the product or nozzle which leaks air or does not function properly.

- Always disconnect the battery pack before making adjustments, servicing, or when the product is not in use.
 - Do not carry the product by the nozzle.
 - Inspect the product yearly for cracks, pin holes or other imperfections that could cause the product to become unsafe.
 - Never cut or drill holes in the product.
 - Never leave the product unattended with the nozzle attached to the item being inflated.
 - To reduce the risk of electric shock, do not expose the product to rain. Store the product indoors.
 - The product is intended for household use only.
 - Do not use the product as a breathing device.
 - Never direct a jet of compressed air toward people or animals. Take care not to blow dust and dirt towards yourself or others. Following this rule will reduce the risk of serious injury.
 - Protect your lungs. Wear a face or dust mask if the operation is dusty. Following this rule will reduce the risk of serious personal injury.
 - Do not use the product to spray chemicals. Your lungs can be damaged by inhaling toxic fumes.
 - Check damaged parts. Before further use of the inflator or air tool, a guard or other part that is damaged should be carefully checked to determine that it will operate properly and perform its intended function. Check for alignment of moving parts, binding of moving parts, breakage of parts, mounting, and any other conditions that may affect its operation. A guard or other part that is damaged should be properly repaired or replaced by an authorised service centre. Following this rule will reduce the risk of shock, fire, or serious injury.
- Risk of bursting. Carefully monitor objects during inflation.
 - Save these instructions. Refer to them frequently and use them to instruct others who may use this inflator. If you loan someone this inflator, loan them these instructions also.
 - Ambient temperature range for tool during operation is between 0°C and 40°C.
 - Ambient temperature range for tool storage is between 0°C and 40°C.
 - The recommended ambient temperature range for the charging system during charging is between 10°C and 38°C.

ADDITIONAL BATTERY SAFETY WARNINGS

- To reduce the risk of fire, personal injury, and product damage due to a short circuit, never immerse your tool, battery pack or charger in fluid or allow a fluid to flow inside them. Corrosive or conductive fluids, such as seawater, certain industrial chemicals, and bleach or bleach-containing products, etc., can cause a short circuit.
- Ambient temperature range for battery during use is between 0°C and 40°C.
- Ambient temperature range for battery storage is between 0°C and 20°C.

TRANSPORTING LITHIUM BATTERIES

Transport the battery in accordance with local and national provisions and regulations.

Follow all special requirements on packaging and labelling when

transporting batteries by a third party. Ensure that no batteries can come in contact with other batteries or conductive materials while in transport by protecting exposed connectors with insulating, non-conductive caps or tape. Do not transport batteries that are cracked or leaking. Check with the forwarding company for further advice.

MAINTENANCE

- The product should never be connected to a power source when assembling parts, making adjustments, cleaning, performing maintenance, or when the product is not in use. Disconnecting the product from the power supply will prevent accidental starting that could cause serious injury.
- When servicing, use only original manufacturer's replacement parts, accessories and attachments. Use of any other parts may create a hazard or cause product damage.
- Avoid using solvents when cleaning plastic parts. Most plastics are susceptible to various types of commercial solvents and may be damaged by their use. Use clean cloths to remove dirt, carbon dust, etc.
- Do not at any time let brake fluids, gasoline, petroleum-based products, penetrating oils, etc., come in contact with plastic parts. Chemicals can damage, weaken or destroy plastic which may result in serious personal injury.
- For greater safety and reliability, all repairs should be performed by an authorised service centre.

SYMBOLS ON THE PRODUCT



Safety alert

Li-Ion

Lithium-ion battery



Direct current

V

Volt



Regulatory Compliance Mark (RCM). Product meets applicable regulatory requirements.



Please read the instructions carefully before starting the product.



For indoor use only.



Do not dispose of waste batteries, waste electrical and electronic equipment as unsorted municipal waste. Waste batteries and waste electrical and electronic equipment must be collected separately. Waste batteries, waste accumulators, and light sources have to be removed from the equipment. Check with your local authority or retailer for recycling advice and collection point. According to local regulations, retailers may have an obligation to take back waste batteries and waste electrical and electronic equipment free of charge. Your contribution to the reuse and recycling of waste batteries and waste

electrical and electronic equipment helps to reduce the demand of raw materials. Waste batteries, in particular containing lithium, and waste electrical and electronic equipment contain valuable and recyclable materials, which can adversely impact the environment and the human health if not disposed of in an environmentally compatible manner. Delete personal data from waste equipment, if any.

SYMBOLS IN THIS MANUAL



Note



Parts or accessories sold separately

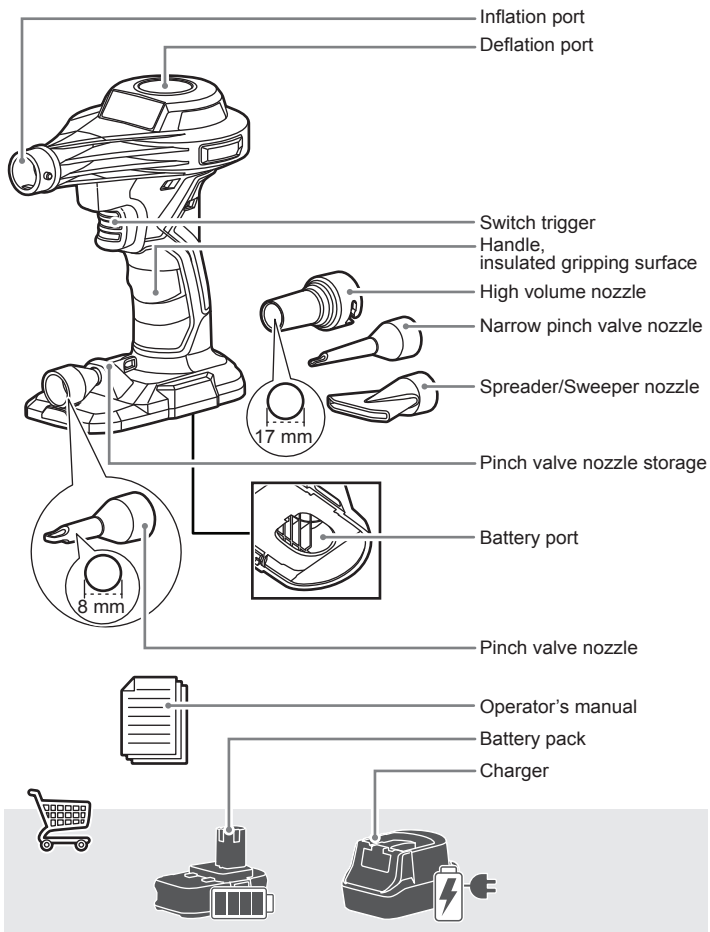

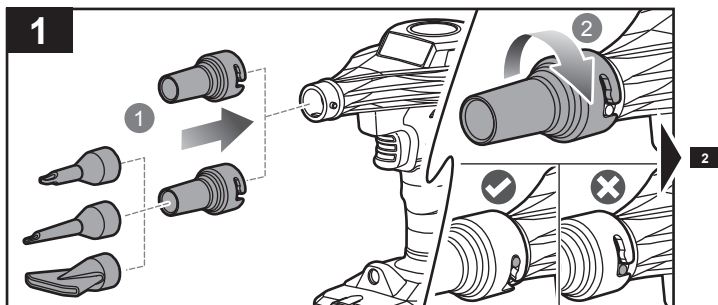

Slide the wide end of the high volume nozzle onto the inflator. The tab on the inflator should slide into the slot on the nozzle. Turn the nozzle clockwise until the nozzle is secure.

To install the pinch valve nozzle, narrow pinch valve nozzle or spreader nozzle, slide the wide end of the nozzle onto the end of the high volume nozzle until it is securely attached.

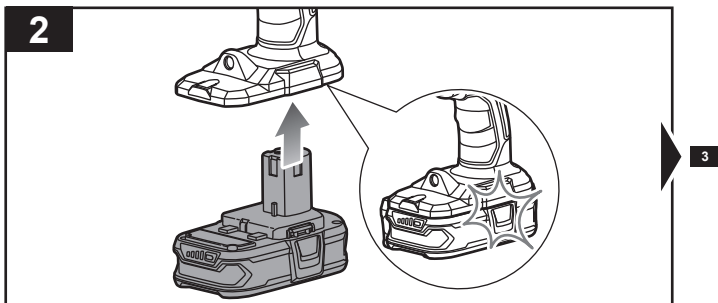

Install the battery pack.

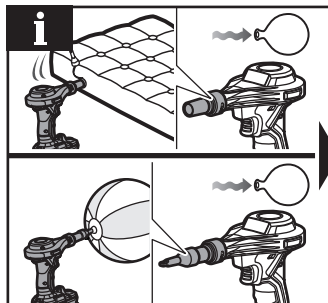
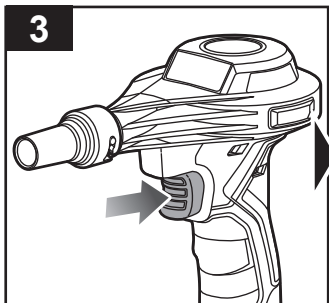

Pull and release the switch trigger to start the inflator. The inflator will continue to run until it is turned off.
When the item is fully inflated, pull and release the switch trigger to stop the flow of air.
Remove the nozzle from the inflated item and close the item's air port.

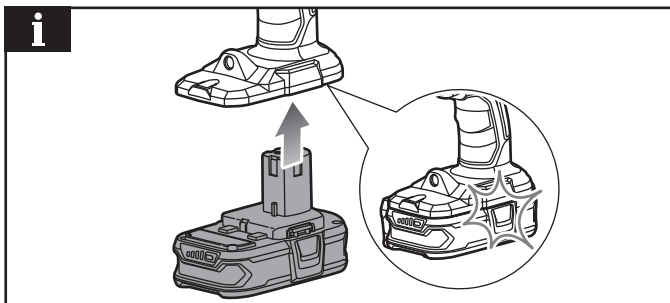

Remove the battery pack after use.

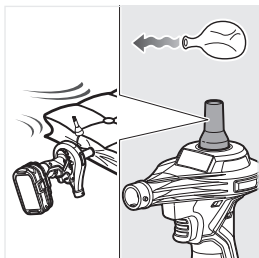

DEFLATING

1. Remove the battery pack.
2. Turn the high volume nozzle counterclockwise and remove it from the inflator. Insert the high volume nozzle into the deflation port on top of the inflator.
3. Install the battery pack.
4. Insert the nozzle into the air port on the inflatable item. Pull and release the switch trigger to start the inflator. The inflator will continue to run until it is turned off. When the item is fully deflated, pull and release the switch trigger to stop the inflator. Remove the nozzle from the deflated item and close the item's air port.

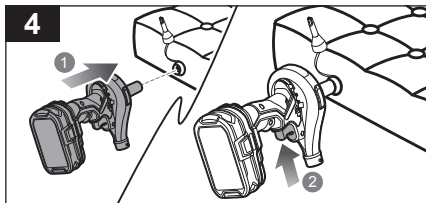
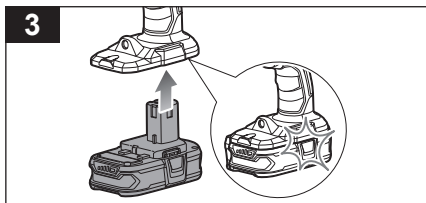
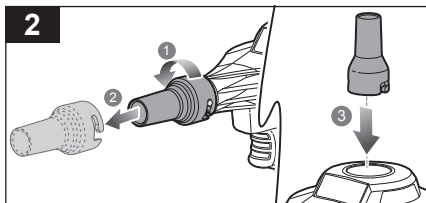
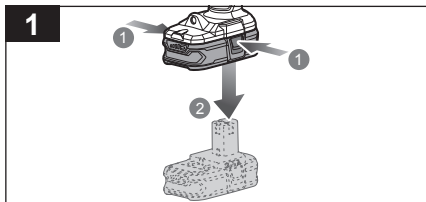

PRODUCT SPECIFICATIONS

High volume inflator

Model	RV118
Voltage	18 V 
Maximum pressure	0.50 PSI, 0.03 Bar, 3.45 kPa
Air flow	≥509 L/min
Duty cycle	Continuous
Weight - excluding battery pack	0.39 kg

Measured sound values determined according to EN 62841:

A-weighted sound pressure level	$L_{pA} = 76.0$ dB(A)
Uncertainty K	3 dB(A)

A-weighted sound power level	$L_{wA} = 84.0$ dB(A)
Uncertainty K	3 dB(A)

Wear ear protectors.

The vibration total values (triax vector sum) determined according to EN 62841:

Vibration emission value	$a_h \leq 1.4$ m/s ²
Uncertainty K	1.5 m/s ²

BATTERY AND CHARGER

Compatible battery pack (not included)

RB18L15	RB18L20A	RB18L40A	RB1840C
RB18L15A	RB18L25	RB18L50A	RB1850C
RB18L15B	RB18L25A	RB18L90A	RB18120T
RB18L20	RB18L40	RB1815C	





⚠ WARNING! The declared vibration total values and the declared noise emission values given in this instruction manual have been measured in accordance with a standardised test and may be used to compare one tool with another. They may be used for a preliminary assessment of exposure.

The declared vibration and noise emission values represent the main applications of the tool. However, if the tool is used for different applications, used with different accessories, or poorly maintained, the vibration and noise emission may differ. These conditions may significantly increase the exposure levels over the total working period.

An estimation of the level of exposure to vibration and noise should take into account the times when the tool is turned off or when it is running idle. These conditions may significantly reduce the exposure level over the total working period.

Identify additional safety measures to protect the operator from the effects of vibration and noise, such as maintaining the tool and the accessories, keeping the hands warm (in case of vibration), and organising work patterns.







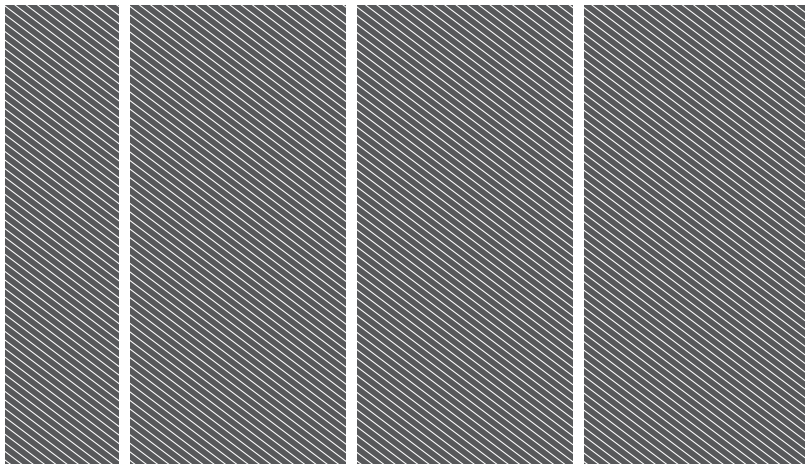

Imported by:

Techtronic Industries Australia Pty Ltd
31 Gilby Road, Mount Waverley, VIC 3149
Melbourne, Australia

Techtronic Industries N.Z. Limited
Unit C, 70 Business Parade South,
Highbrook, Auckland 2013, New Zealand

RYOBI is a trade mark of Ryobi Limited, and is used under license.

20231212v1

