

STRUCTA™

**IT'S GOTTA
BE STRUCTA™**

**INSTALLATION GUIDE
NEW ZEALAND**

STRUCTAflor™

LEADING BRAND

STRUCTAflor™ General Purpose offers a practical, flexible and cost effective choice when building your new home or extension. With a comprehensive range of options, they are ideal for: sub-floors, suspended floors in multi-storey construction, additions and extensions and commercial flooring; as well as a host of other building applications.

With over 50 years of proven performance, STRUCTAflor™ remains the leading product in its class. The trusted performance of STRUCTAflor™ General Purpose, makes the product a clear choice for builders. As the first product of its kind to market, STRUCTAflor™ continues to lead the way in the innovation and development of flooring solutions.



In the building business, your reputation is only as good as the materials you use. That is why when it comes to structural particleboard flooring, you need a product you can trust and a partner you can rely on to keep pace with ever-changing lifestyle and construction requirements.

STRUCTAflor™

- Resin-enriched surface for enhanced weather protection during construction for up to 2 months.
- Certified to AS/NZS 1860.1 for strength, stability and performance.
- Manufactured to precise standards for a secure fit with standard joist layouts, keeping installation fast and reliable.
- Wax-impregnated and edge-sealed for long-term moisture resistance and easy product identification.
- Made from managed and renewable plantation pine.

Note: Particleboard flooring is not to be used in weather exposed end applications.

PRODUCT FEATURES

Designed to provide a total flooring concept, STRUCTAflor™ General Purpose, is particularly suited to platform construction where the floor is laid prior to the erection of walls. The sheets are made from precision milled wood flakes and bonded with moisture resistant synthetic resin. For additional moisture protection during construction and exposure to weather, the upper surface is resin enriched and all edges of the tongue and grooved sheets are coated.

Factory grooved long edges are fitted one side with a distinctive, colour-coded rigid Polypropylene (PP) tongue to ensure a neat, tight fit for adjoining panels

STRUCTAflor™ General Purpose

General purpose particleboard flooring that complies with the requirements for Particleboard Flooring, Class 1, under AS/NZS 1860.1 Particleboard flooring. Featuring a durable, resin-enriched surface and yellow edge coating on PP-tongued variants, it delivers reliable performance for residential flooring applications.

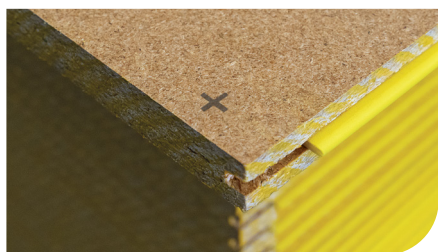

YELLOWtongue™ – 19mm

An internal, general-purpose flooring solution designed primarily for residential buildings, suitable for both platform and fitted flooring construction methods. YELLOWtongue™ is engineered to support imposed loads in general residential areas in accordance with AS/NZS 1170.1:2002 Structural design actions, Part 1: Permanent, imposed and other actions.

At 19mm thickness, the maximum joist spacing for YELLOWtongue™ STRUCTAflor™ General Purpose is 450mm for general residential applications.



Key Points

Storage

STRUCTAflor™ is designed to withstand full weather exposure for up to two months. However, packs should not be left unprotected on site prior to installation. STRUCTAflor™ must be protected from the weather until it is installed, as moisture penetration before installation may result in gaps at flooring joints as the product dries.

When storing outdoors, ensure packs are kept clear of the ground and covered with waterproof sheeting. The cover should be supported on timber battens to allow free air circulation between the sheeting and the product.

Exposure

The product may be exposed to the weather for up to two months. However, it is recommended that the building be enclosed as soon as possible after the floor is laid. During this exposure period, prevailing weather conditions may affect the surface condition of the board and can result in minor swelling once the building is enclosed. Any swelling can be rectified by sanding, provided the depth of material removed does not exceed:

- 1mm over the general panel area
- 2mm within 50mm of any supported edge

Any water that ponds on the platform should be removed by sweeping or by drilling drainage holes no larger than 8mm in diameter and spaced no closer than 1m apart.

Installation

Adhesives

Either flexible or rigid construction adhesive to be used. However, flexible adhesives are recommended.

Fasteners

Screw fixing is the preferred method.

Product Details

Thickness: 19mm

Surface Qualities: Upper surface is unsanded to retain a resin film, retard moisture and provide a working surface during installation.

Edge Coating: Factory applied to all edges of tongue and grooved sheets to reduce moisture ingress. Yellow coating for STRUCTAflor™ General Purpose YELLOWtongue™

Edge Profiles: Tongue and grooved long edges with square cut ends.

Tongue System: Factory fitted, rigid PP tongues ensure a tight fit and precise alignment of unsupported edges.

Resin: Synthetic resins for high moisture resistance.

Identification: Stamps on the underside of boards indicate required joist spacings.

The Facts That Matter

- Resin Enriched Surface
- Edge Coat
- Wax Impregnated throughout
- Synthetic Resin System
- Meets or Exceeds AS/NZS 1860.1

STRUCTAflor™ General Purpose

- 800mm wide sheet
- Plantation Pine
- Built on 50 years of trust

Joist Spacing

STRUCTAflor™ General Purpose



Thickness	19mm
Joist Spacing (max)	450mm
3600 x 800mm	✓

PHYSICAL PROPERTIES

Health and Safety

The normal health and safety precautions should be taken when working with wood panel products. Machine tools should be fitted with dust extractors and work areas kept clean. The wearing of a dust mask (AS/NZS 1715 and AS/NZS 171) and safety glasses (AS/NZS 1337) is recommended. Storage and work areas should be adequately ventilated.

Fire Hazard Properties

Particleboard used as a flooring substrate – NZBC - Clause C - Early Fire Hazard Properties (AS/NZS 1530.3-1999).

This fire hazard property is used where particleboard is not the final floor covering such as under a carpet or tiled floor. In this case the Early Fire Hazard properties are required for most single family homes.

Table 3. Properties of typical particleboard flooring
Source: AWTA (May 2019) test reports 19-002324/5/6

Properties	YELLOWtongue™ 19mm	
	Index	Range
Ignitability	13	0-20
Spread of flame	4	0-10
Heat Involved	4	0-10
Smoke Developed	3	0-10

Table 4. Test results for typical STRUCTAflor™
Source: AWTA (June 2019) test reports 19-001482/5/6

Properties	YELLOWtongue™ 19mm
Average Critical Radiant Flux	6.0kW/m ²
Average Smoke Obscuration (Smoke Development Rate)	17% min

Thermal Insulation

The thermal conductivity of STRUCTAflor™ General Purpose is 0.12 W/mK. Thermal resistance (R-values) calculated in accordance with the relevant provisions of AS/NZ4859.1 for the nominated thicknesses are:

Table 5.

Product	R-value (Thermal resistance m ² K/W)
	YELLOWtongue™ 19mm
Flooring	R0.16



PRODUCT SPECIFICATIONS

Product Range

IN	Product	Sheet Dimensions		Weight Chart				
		Thickness mm	Sheet Size mm	Pack Size	Pack Weight kg	Sheet Weight kg	Coverage/sheet m ²	Domestic Flooring Max. Joist Spacing mm
20011	General Purpose	19 YELLOWtongue™	3600 x 800	30	1132.7	37.2	2.88	450

Particleboard Flooring Properties

Property	Units	Thickness
		YELLOWtongue™ 19mm
Density	kg/m ³	690
Bending Strength (MOR)	MPa	19
Bending Stiffness (MOE)	MPa	2750
Internal Bond Strength	MPa	0.55
Surface Water Absorption	g/m ²	150
Thickness Swell (24 hr)	%	8
Glue Bond Quality	MPa	8.6
Thickness Stability	%	14
Formaldehyde Potential (Desiccator Method)	mg/L	1.3 (E1)

The table contains typical properties for particleboard flooring in internal application where they are not subject to prolong wetting or high level of relative humidity.

The equilibrium moisture content of the board should be maintained below 13%.

Table 2. Typical Property Values for Class 1 Particleboard Flooring

Source: Facts About Particleboard and MDF EWPA 2010 – www.ewp.asn.au

APPLICATION AND CONSTRUCTION REQUIREMENTS

Ground Clearance

A minimum clearance of 550mm, must be observed between the underside of the flooring and the ground.

Construction Requirements

General

STRUCTAflor™ may be used over conventional joists in single storey or two storey construction in accordance with NZS 3604:2011 Timber Framed Buildings. The supporting frame should comply with the requirements of the New Zealand Building Code and/or be certified by a professional engineer, as may be required by the building authority.

Wet Area Rooms

STRUCTAflor™ is not approved for use in wet areas such as bathrooms, laundries, etc.

Ventilation / Vapour Barriers

Ventilators to external and internal subfloor walls should satisfy the requirements of the New Zealand Building Code, be evenly spaced and allow a clear cross-flow of air beneath the floor. Particular attention should be given to the ventilation of corners.

Increased levels of ventilation are advised for subfloor spaces which are subjected to occasional dampness.

The particle flooring subfloor members should not be subjected to prolonged dampness. The moisture content of particleboard flooring should be maintained below 13% moisture content.

To assist drainage and ventilation, the ground should be graded to fall and weep holes provided in the external walls. In some circumstances 0.2mm (minimum) plastic sheet ground covers may be used to retard the rise of moisture vapour.

The underside of STRUCTAflor™ facing the ground must not be coated with sealant.

Framing

Particleboard flooring may be used over timber or metal floor joist systems.

For best results with timber frames, deep floor joists (150mm or more) such as those used in upper story construction, should be seasoned and gauged.

Securely fix floor joists to bearers. The top surface of the joists must be level to ensure the flooring lies flat and even. Kiln-dried or stabilised timbers are recommended. Green (unseasoned) timber, including joists and bearers, may shrink unevenly as it dries, which can cause distortion of the particleboard flooring and result in nail heads protruding once the timber stabilises in moisture content.

Floor joist spacings must not exceed the span capacity of the particular particleboard flooring product. Refer to "Applications" or "Product Details".



PRODUCT INSTALLATION

Particleboard flooring will expand and contract as sheets respond to changes in atmospheric moisture. Allowance for this movement must be made throughout the floor area by providing gaps and special joints as appropriate to accommodate sheet expansion.

Expansion Joints

For small areas, the gaps left between panels when laid by hand should accommodate normal hygroscopic movement. For large floor areas the hygroscopic movement of the particleboard flooring should be taken into account in the design.

For continuous floor widths over 10m, measured at right angles to flooring, intermediate expansion joints shall be provided in addition to the perimeter gaps. This joint shall be either a single 20mm wide gap (under a wall or across a hallway), or smaller gaps with closer spacing to give an equivalent space.

Installation Details

Particleboard flooring sheets are laid with their long side across floor joists and ends butted over a joist. Sheet end joints should be staggered because any slight rounding of sheet corners may present a hole in the floor if four corners come together.

Select a starting point for laying and set a string line to ensure the first sheet is square with the joists. Position the first sheet with its tongued edge to the string line and note the printed information on the sheets regarding top surface.

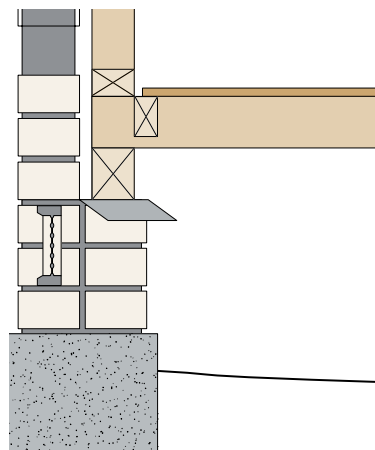

Fitted construction

Each sheet must be supported by at least three joists. If this is not possible (cutting in around the room perimeter) then noggins should be fixed under the edges of these smaller pieces.

Arrange sheets as in "Platform Installation" e.g. T&G edges at right angles to floor joists.

Ensure floor joists and trimmers are installed at the room perimeter to support sheet edges and ends. Provide 10mm clearance between sheet edges and wall frames. Cover with skirting fixed through the wall linings to the wall frame or other fixed objects like masonry or columns. Stagger end joints (stretcher bond pattern) and locate centrally over joists.

Fitted Construction

This applies to STRUCTAflor™ General Purpose installation after the walls have been erected. Floor joists and trimmers must be installed so that all sheet edges at the room perimeter are supported.

Platform Construction

The product is particularly suited to platform construction. The method provides a working platform for wall and roof frame erection and contributes to time and cost savings.

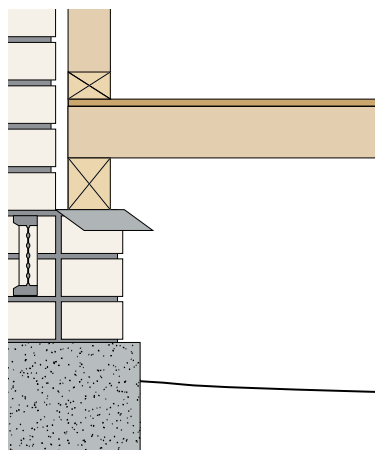

Platform construction

In platform construction, sheet edges at the building perimeter are aligned with the outside edges of external wall frames. Wall plates are laid over product and fixed through the sheets to the joists.

Installation methods depend on the edge profile and the construction method – either "fitted" or "platform".

Adhesives

Requirement and Application

Adhesive fixing provides a rigid floor. The use of construction adhesive in conjunction with nails or screws is mandatory.

For cartridge systems, cut the nozzle to produce a 5mm bead. For foam systems, regulate the flow to achieve the required adhesive bead diameter.

Clean any dirt, grease or water from surfaces to be bonded.

Exude a continuous, 5mm diameter bead of adhesive to each joist to be covered by flooring. Apply two beads to joists where sheets butt together.

An extra bead applied along the tongue before sheets are pressed together will help to achieve a squeak free floor system. Any excess glue squeezed out should be cleaned off.

Position sheets within approximately ten minutes of applying the adhesive. Do not allow the adhesive to skin over before applying sheets.

Nail or screw flooring sheets within 15 minutes of positioning sheet.

Remove excess adhesive from sheet surface before it dries. Use a scraper and rag dampened with mineral turps (or appropriate solvent).

To seal cut edges of the sheets, apply a bead of adhesive to the edge. Butt the edge firmly up to the adjoining sheet and remove excess adhesive. Alternatively, the adhesive may be spread over the cut edge with a spatula.

PRODUCT INSTALLATION

Standard Fixing – for Tongue and Groove Panels

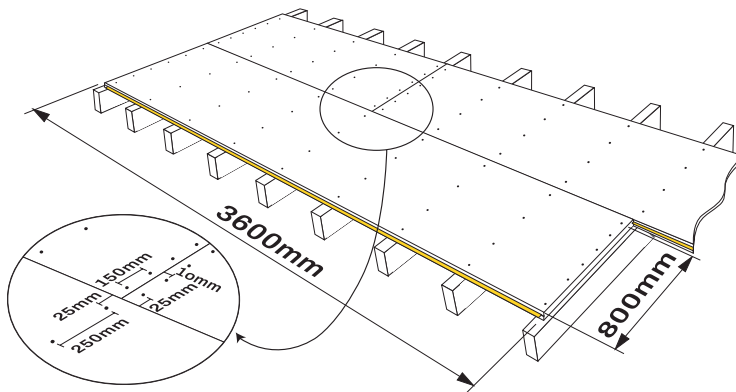

Figure 1 - Staggered Fixing

Fastener Spacing – 3600x800 sheets
 250mm maximum centres – body of sheet
 150mm maximum centres – sheet edges

25mm from T&G edges
 10mm (minimum) from square edges (butt joint)

Platform Exposure

The product may be exposed to the weather for up to two months. However, it is always advisable to enclose the building as soon as possible after laying the floor. During exposure, prevailing weather conditions can influence the surface condition of the board and may cause minor swelling. Following the enclosure of the building, this can be removed by sanding – see Figure 2.

Remove any water that ponds on the platform by sweeping or by drilling holes (no larger than 8mm in diameter and no closer than 1 meter apart) in positions which will eventually be covered by wall plates, cupboards or skirting.

Excessive and differential drying of particleboard flooring sheets after it has been wet may result in cupping and shrinkage of the product which could, in extreme circumstances, cause pull-out or pull-through of nail heads. If this occurs, screwing the flooring sheet to the joists will be required to prevent the floor from movement and possible squeaking. In severe cases, shading may be required, or alternatively, light wetting of the flooring surface may be required to recondition sheets back to uniform moisture contents.

Do not apply plastic sheeting or surface sealants over the exposed platform as they will trap moisture and retard drying out. Furthermore, this can result in dimensional change.

The hygroscopic movement of the particleboard flooring (or any flooring) should be taken into account in the design.

General damage to the flooring surface can occur through various means. Avoid the build up of plaster, concrete, paint etc. on the floor and do not use the floor:

- For stacking heavy materials like bricks, tiles, sand, cement or
- As a mixing table for the mixing of cement, mortar, etc.

Minor swelling that may result due to prolonged exposure to weathering (resulting from the hygro-expansivity of particleboard) can be removed by sanding following the enclosure of the building. The depth of material removed shall not exceed the following:

- 1mm – Over the general panel area
- 2mm – Within 50mm of any supported edge

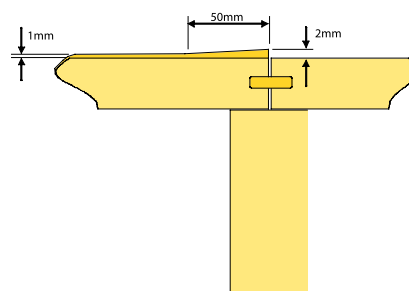

Figure 2. Sanding Provision

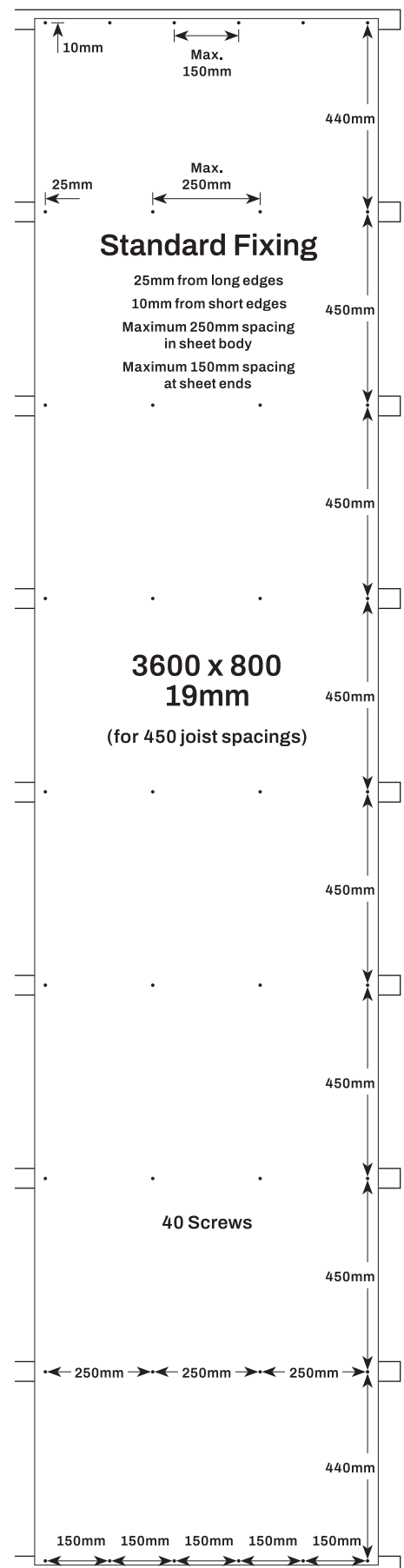

Figure 3. Fixing plan for 450mm joist spacing.

PRODUCT INSTALLATION

Fasteners

Select an appropriate fastener from Table 2. The fastener type, length and gauge is based on the particleboard thickness, joist material and available fastening equipment.

Fastener Spacing

For all flooring system's sheet edges, space fasteners at 150mm centres. Keep fasteners at least 10mm from square edges and 25mm from tongue and grooved edges.

In the body of the sheets, space fasteners at 250mm centres for 800mm wide flooring. Drive fasteners flush with the STRUCTAflor™ General Purpose surface. Immediately prior to sanding, punch fasteners 2mm below the surface.

Fixing to Timber I-beam joists

When particleboard flooring is fixed to I-beam joists, screws (not nails) should be used. I-beam flanges may only be 35mm thick and nails will penetrate through and may not have sufficient holding strength.

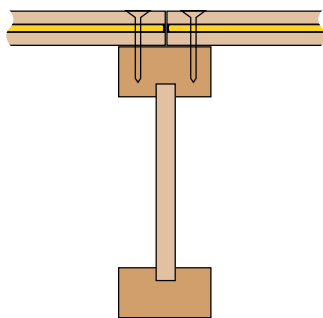

Figure 4. Fixing to EWP I-Beam

Table 1. Sheet Quantity Estimator

How many sheets do you need?										
Width	Thickness and Length	Area	Size of Floor m ²							
			10	25	50	75	100	150	200	250
800mm	19mm x 3600	2.88m ²	4	9	18	27	35	53	70	87

Table 2. Fasteners

Fastening Method	Joist Material	Fastener Type	Flooring	Minimum Fastener
Screw Fixing (Preferred Method)	All timbers	Type 17 countersunk, self-drilling wood screws	19mm	10g x 50mm
Screw Fixing	Steel	Countersunk self-embedding head, self-drilling screws, preferably with self breaking cutter nibs	19mm	10g x 45mm
Manual Nailing	Softwood	Bullet head or flathead nails	19mm	65mm x 2.8mm
Machine Driven Nailing	Softwood	D head, round head or finished head	19mm	65mm x 2.5m*

* Available in D head or round head only.

Note:

1. Use galvanised nails designated for wet areas.
2. Skew bullet or jolt head nails for improved holding.
3. Steel screws should be suitably coated to resist corrosion.
To determine if there are alternative methods please contact your Sales Manager.

DECORATIVE AND SURFACE FINISHING

Particleboard flooring is an ideal base for underlayments, floor coverings and finishes. Surface treatments include carpet, vinyl sheet or tile, cork, linoleum, quarry or ceramic tile and clear or tinted paint coatings.

Concrete Surfacing

Concrete floors in domestic, commercial and industrial buildings can be upgraded with particleboard flooring to change the surface characteristics and adapt the floor for special purposes, e.g. work areas, goods storage, display, sport or recreation, children's play areas, etc. or as a base for decorative timber flooring. Particleboard flooring provides a uniform, comfortable "walk on" surface and the feeling of warmth associated with wood.

STRUCTAflor™ provides the ideal base surface for base under decorative timber flooring or over a concrete slab.

Concrete Surfaces

The concrete should be dry, reasonably flat and free of dirt, oil, grease or fatty substances. A moisture impervious membrane should be located beneath slabs on the ground.

Prior to installation, it is necessary to ensure that the concrete is sufficiently level to accept the system. Where the slab is greater than 3mm out of level over any 1500mm length, a concrete topping (leveling compound), grinding or packing should be used. Slabs on ground should be constructed with a continuous under slab vapour barrier (e.g. 0.2mm thick polyethylene).

Timber floors should not be installed until the concrete slab has a moisture content less than 5% (generally achieved after slabs have cured for approximately 4-6 months). In old slabs, moisture contents should be below this level and if not, care should be exercised.

Various methods are available to test the moisture content of concrete, including resistance metres, capacitance metres and hygrometres.

Preparation

Preparation of particleboard flooring to receive floor surfacings will depend on the type of covering or finish and the effect of weather exposure on the floor.

Preparatory work should be undertaken only when the building is closed and weather tight. STRUCTAflor™ that has been wetted must be allowed to dry to a moisture content below 12%.

Check that the STRUCTAflor™ is fixed tightly to joists, as per "Installation Details" page 9.

Drive fasteners below the floor surface to facilitate sanding and minimise "nail popping" in the event of substructure shrinkage.

Sanding

Sand the surface of the product to level sheet joints and fixing points, even out irregularities and remove any loose weathered particles. For general purpose sanding use 40-60 grit closed coat paper. Refer to sanding provisions detailed under "Platform Exposure" above.

Heavier sanding, with maximum 40 grit paper, may be required on floors which have been exposed to severe wetting. Avoid excessive sanding and limit to a 1mm maximum cut over general floor areas, 2mm maximum cut over supported sheet joints.

For clear and tinted paint finishing, the product should be fine sanded with 100 grit closed coat paper. After sanding, remove all dust, preferably by vacuum cleaning. The prepared surface should be dry, clean and free of any surface contamination, e.g. paint, oil, etc.

Quarry and Ceramic Tiles

Porta recommends the use of a fibre cement underlay in all ceramic tile applications.

Vapour Barriers

An impervious moisture barrier, e.g. 0.2mm polyethylene, should be laid over any concrete surfaces subject to dampness. Lap and tape all joints and fold the barrier up walls. Loose lay the STRUCTAflor™ as outlined under "Fixing".

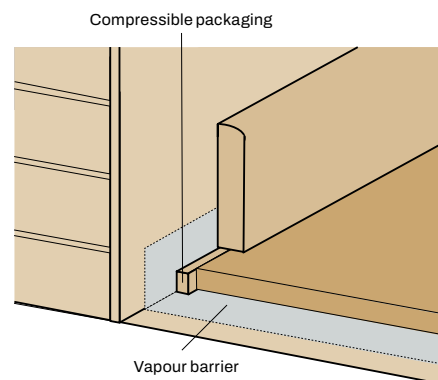

Note:

STRUCTAflor™ sheets may vary in colour and appearance. The variation will show through clear and tinted finishes.

FAQ

Fixing

Can nails be used for fixing to steel joists?

No, this is not recommended.

Can nails be used for fixing to I joists?

We recommend screw fixing to I joists. Typically, the I joist flange is 35mm thick, which will result in the nail penetrating through the flange and reducing the holding capacity of the nail.

How do you minimize the risk of a squeaky floor?

For best results, it is recommended to use screws and adhesive to fix your floor.

Do I need to use adhesive to fix STRUCTAflor™ along with screws/nails?

Yes, the use of adhesive is mandatory when fixing particleboard flooring.

If it is going to rain during installation, should I cover STRUCTAflor™ with plastic or similar?

No, covering the surface during installation will trap the moisture, this can then lead to mould and other moisture related issues.

After Fixing

Why has my STRUCTAflor™ swollen along the edges?

This swelling can occur when the product is exposed to weather during construction. As STRUCTAflor™ is manufactured from natural materials, moisture exposure may result in minor swelling, typically at the edges. Once the floor has dried, this can be corrected by sanding within the specified tolerances. The floor will remain fit for its intended purpose with no long-term performance issues.

Why have gaps appeared between sheets?

This is generally caused by sheets becoming wet prior to installation or by excessive drying after installation. In most cases, this will not result in a structural issue. The gaps may be filled with an elastomeric filler; however, this should only be done once the roof is installed or the floor is protected from the weather.

Can STRUCTAflor™ expand and contract with changes in moisture conditions?

Yes. Like all timber-based products, STRUCTAflor™ can expand or contract as the moisture content of the panel changes. The normal moisture content of STRUCTAflor™ should be between 8 and 13%.

Shrinkage can cause gaps between sheets. This can be minimised by storing STRUCTAflor™ under cover and keeping it dry prior to installation. Expansion can occur on large floors exposed to heavy or continuous wetting. Drilling holes up to 8mm in diameter can help minimise surface water pooling.

For large, continuous flooring areas, 10mm expansion gaps should be provided at intervals of every 6m. This may be achieved with a single 10mm gap beneath a wall or by distributing smaller gaps between sheet joints that total 10mm.

Areas of Use

Can STRUCTAflor™ be used on covered balconies?

No, the structural integrity of the product could be compromised by regular wetting over the extended life of the balcony.

Can STRUCTAflor™ be used in wet areas ie. bathrooms, laundries and toilets?

STRUCTAflor™ is not approved for use in wet areas such as bathrooms, laundries, etc.

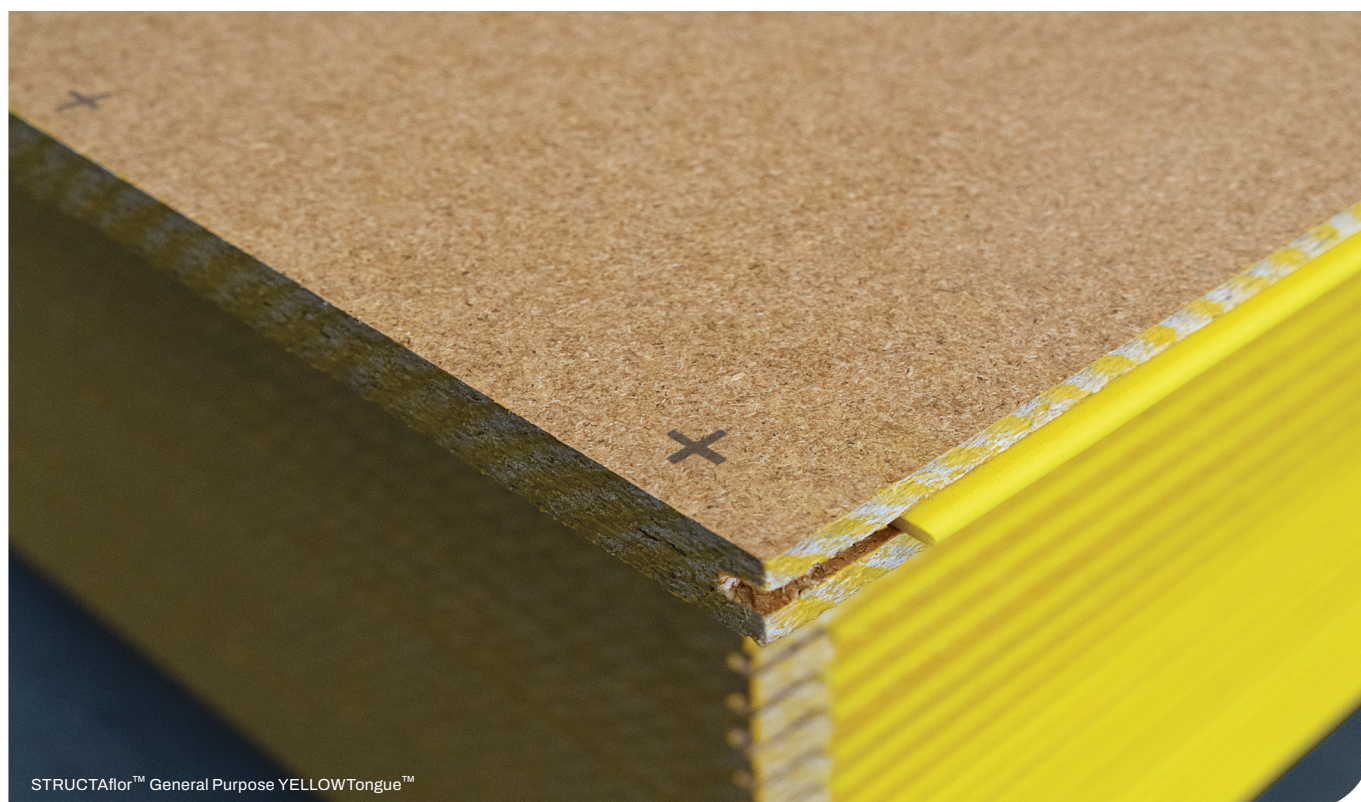

Porta is more than just a timber and panel supplier. We're a trusted partner, delivering purpose-driven products, reliable service, and local expertise.

The STRUCTA™ range is part of the Porta family. Built on generations of know-how, every product is engineered to perform under pressure and deliver the durability builders trust.

Performance you can count on, powered by local knowledge and made to keep your projects moving with confidence.

porta

© Porta Products Pty. Ltd.
Every effort has been made to ensure the information in this brochure is correct. Porta Products reserves the right to modify or delete products at any time as a part of the product development process. Printed colours are indicative only. Any information, claims or pricing needs to be confirmed at the time and point of purchase.

0800 220 608 | sales@porta.co.nz

