

AEG

A18FBLW20

A18FBLW28

Original instructions

Important!

It is essential that you read the instructions in this manual before assembling, operating, and maintaining the product.

Subject to technical modifications.

A18FBLW20

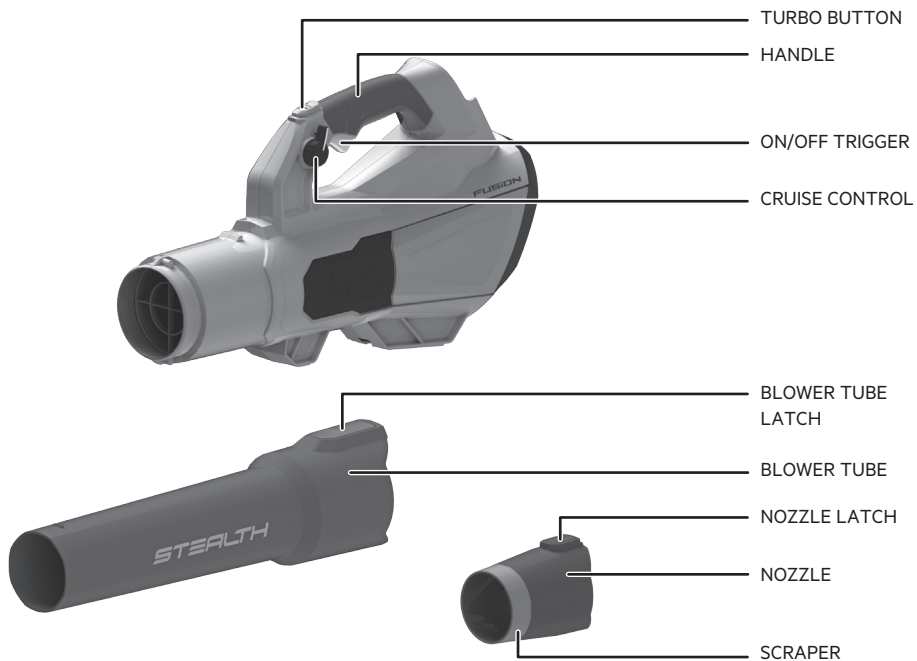

OPERATOR'S MANUAL

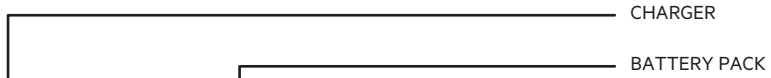

A18FBLW28

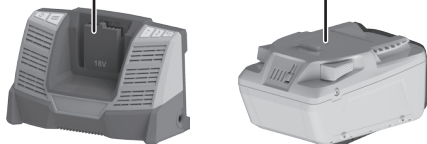
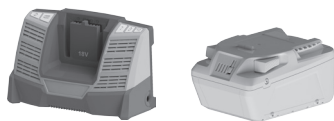

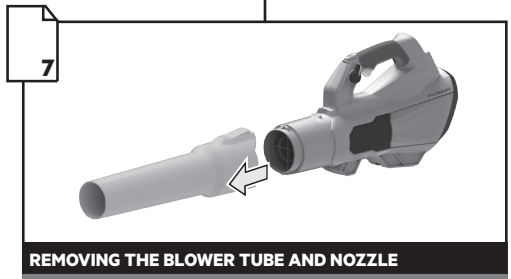
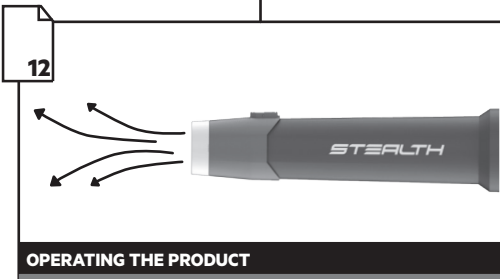
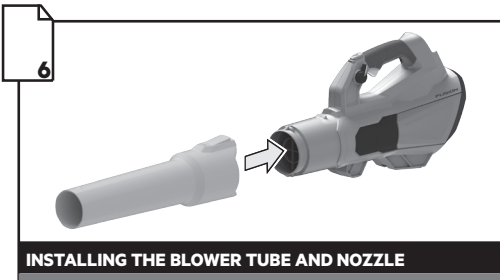
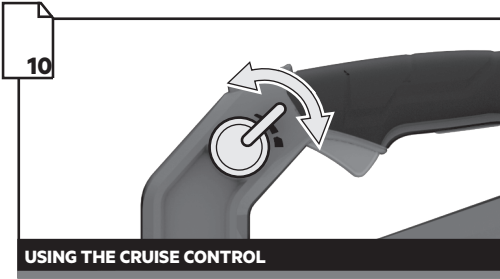
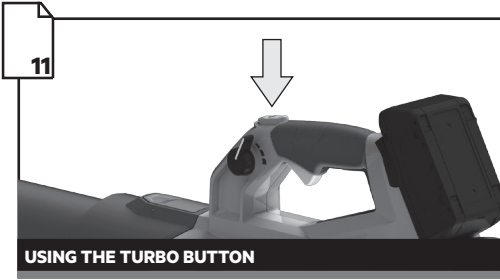

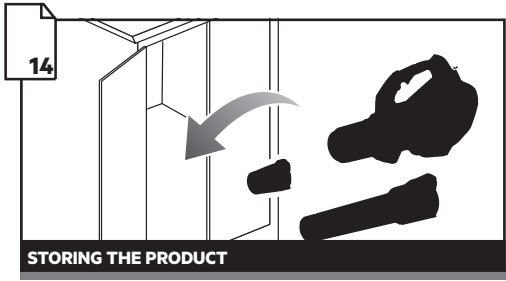
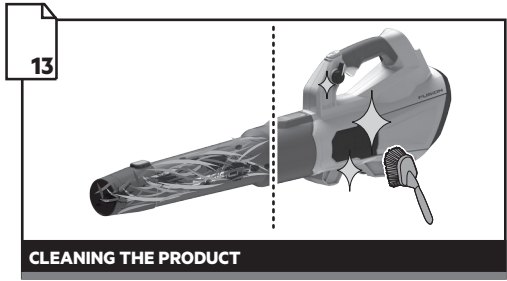
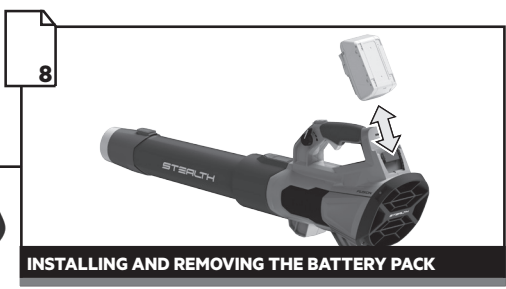
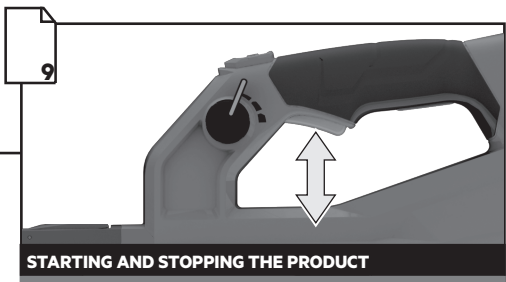
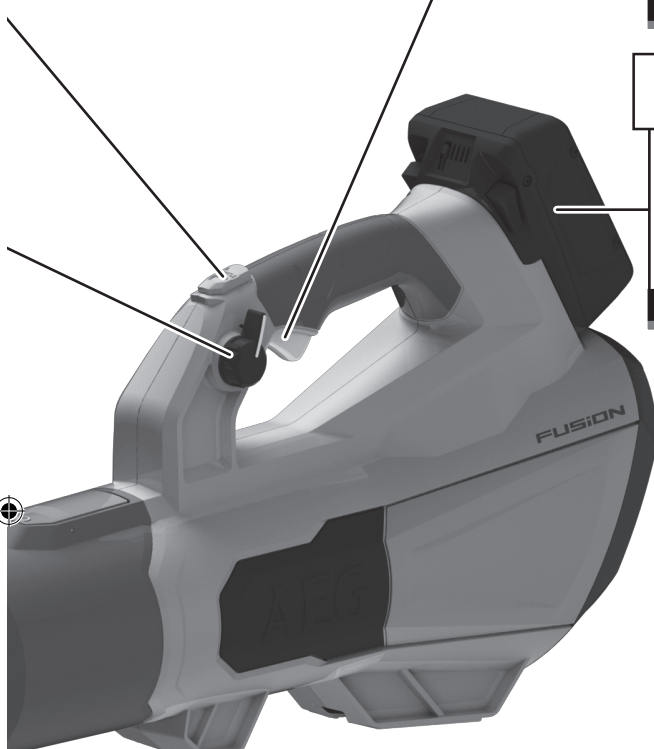

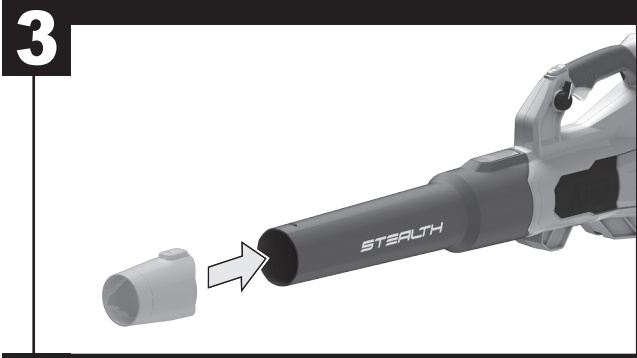
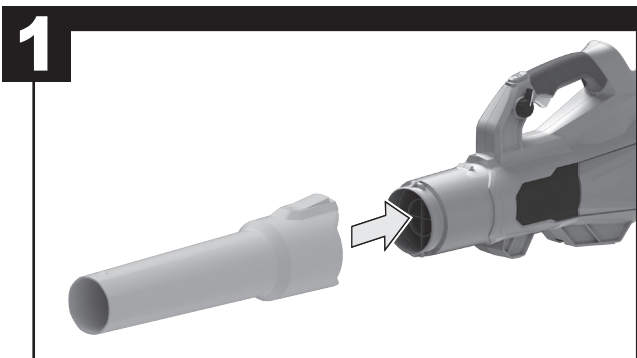
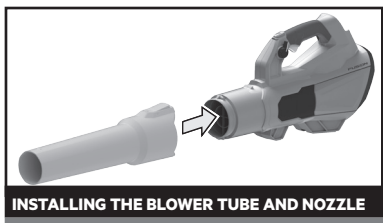

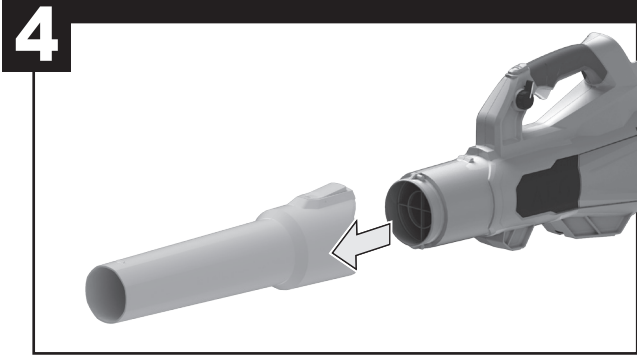
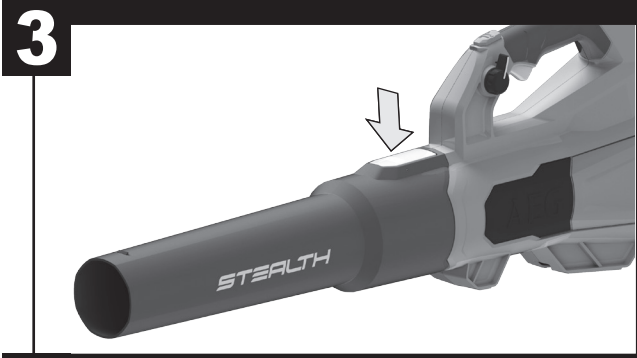
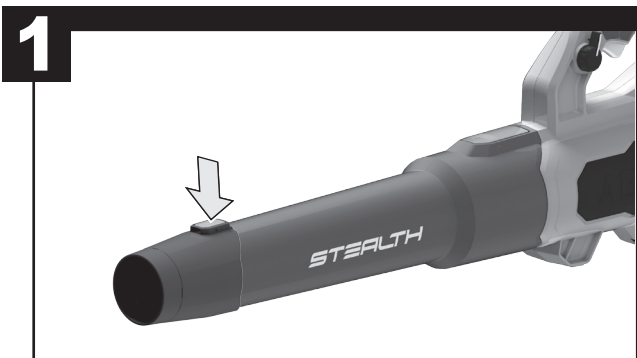
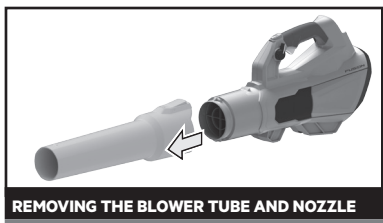



INSTALLING AND REMOVING THE BATTERY PACK

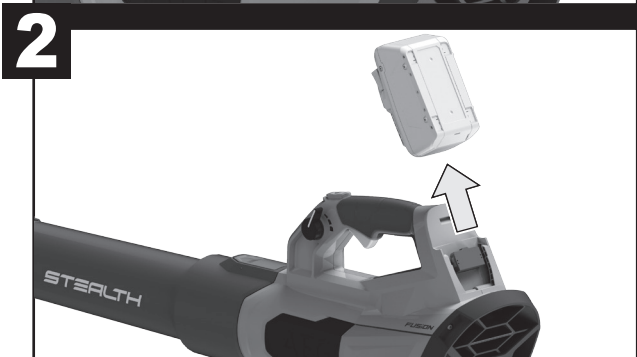
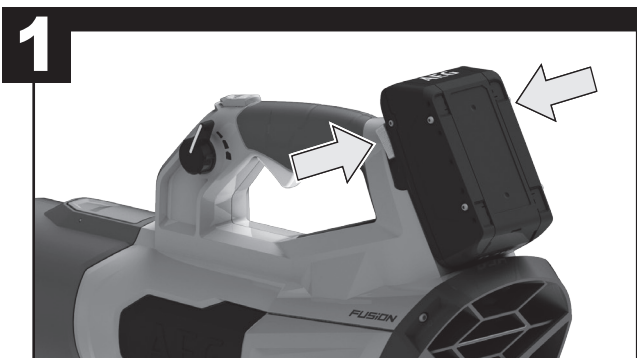
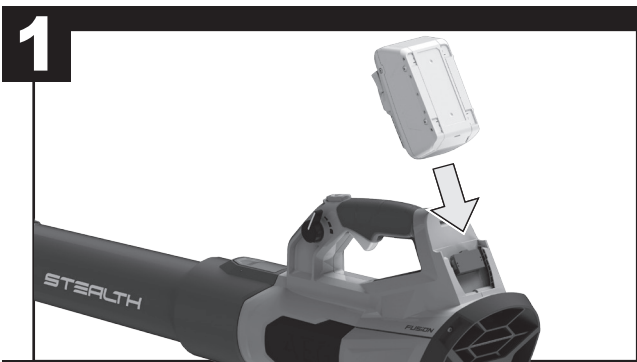

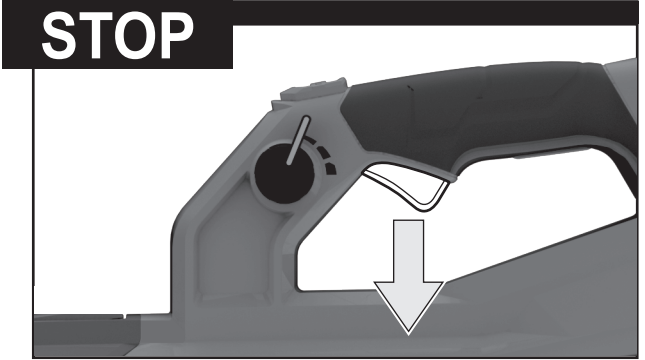
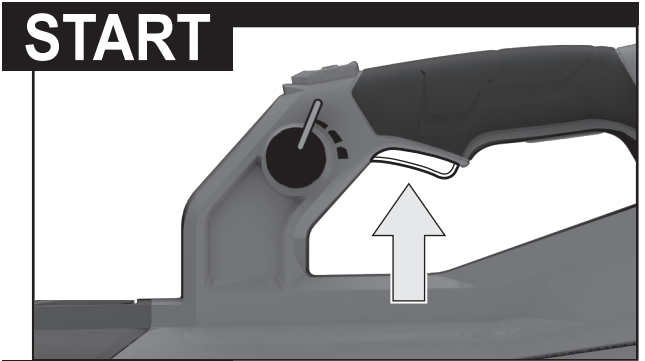
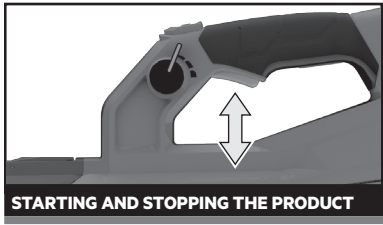

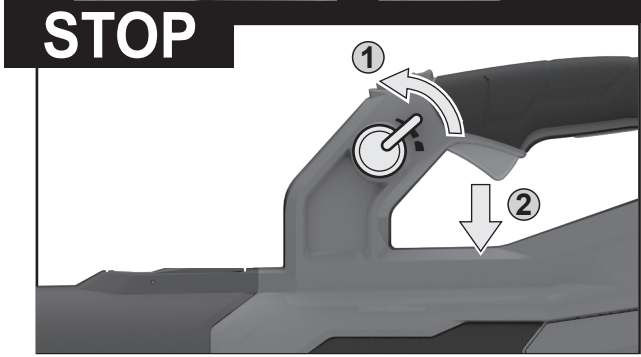
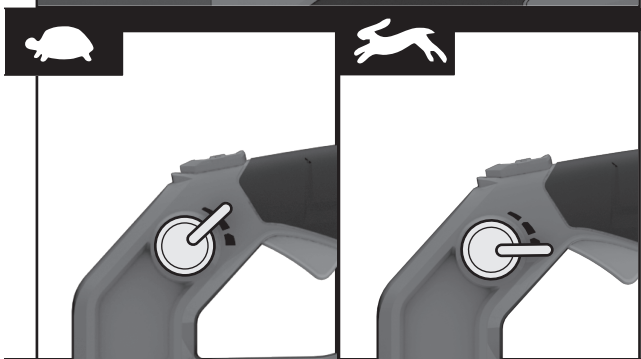
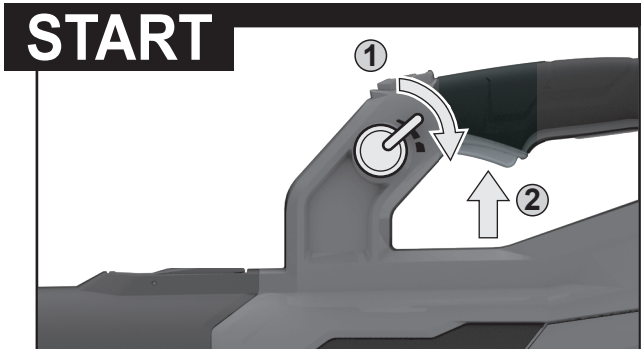
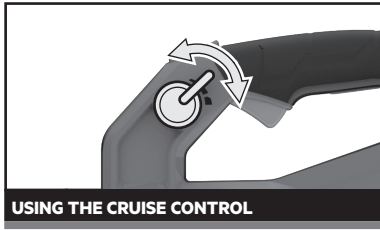

N
th
H
r



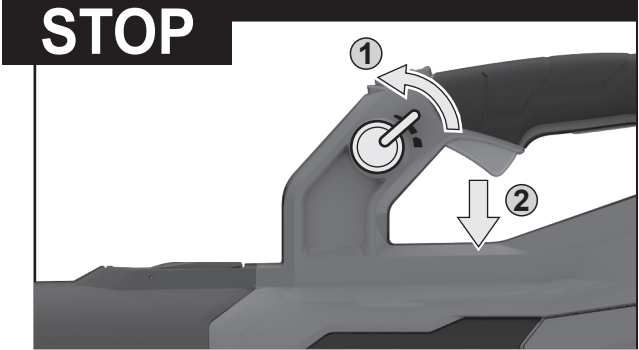
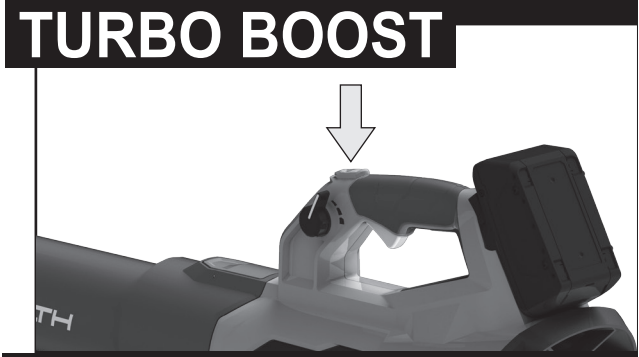
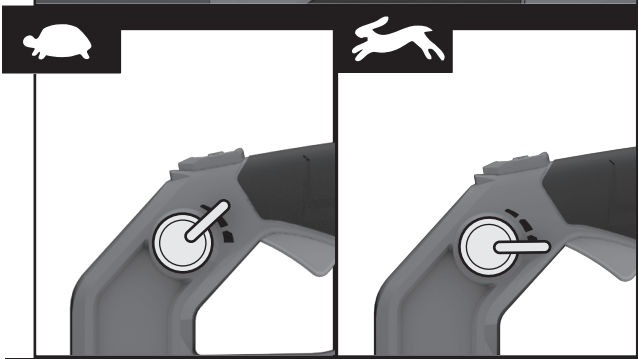
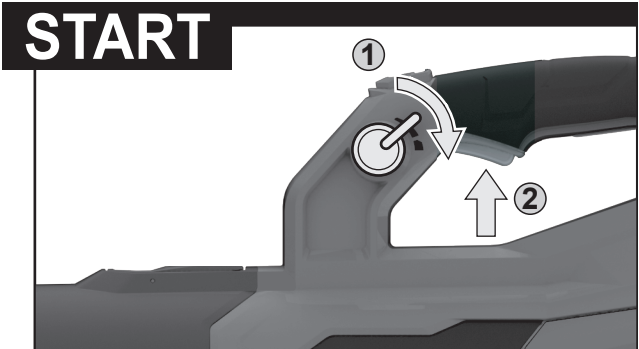
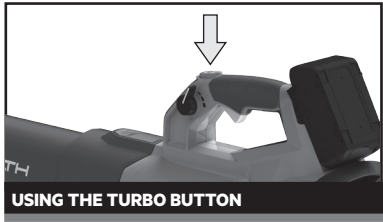

NOTE: The turbo boost button provides the highest performance for the product but will also drain the battery capacity more quickly. Use turbo boost only when required to maximise runtime.



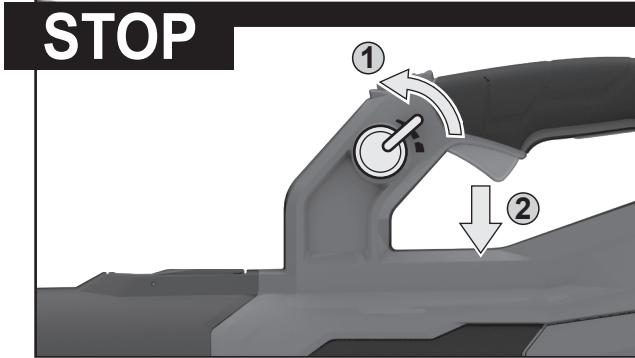
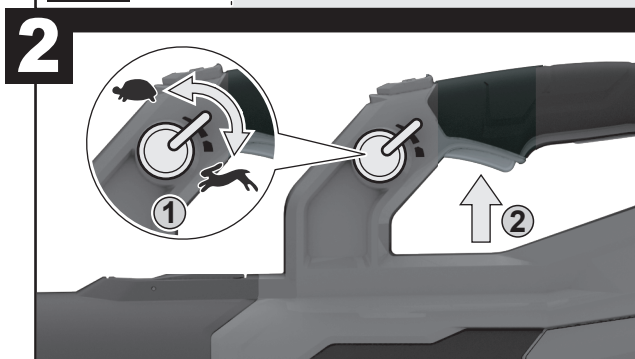
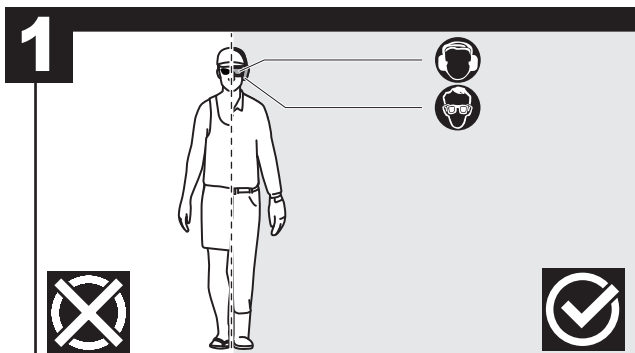
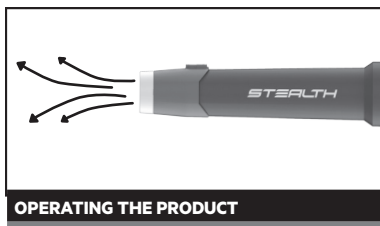

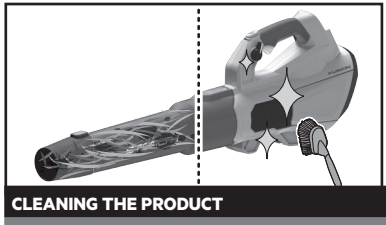

NOTE: Clean the product with a soft, dry cloth or soft brush. Never use water.

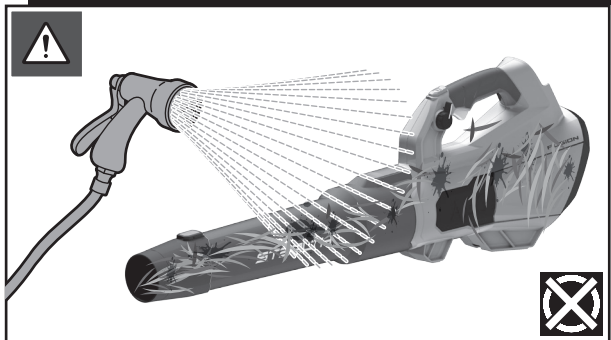
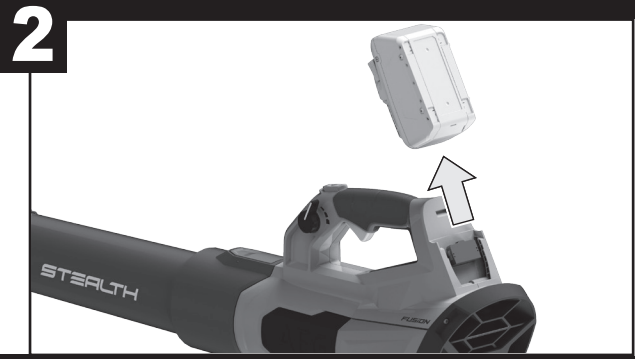
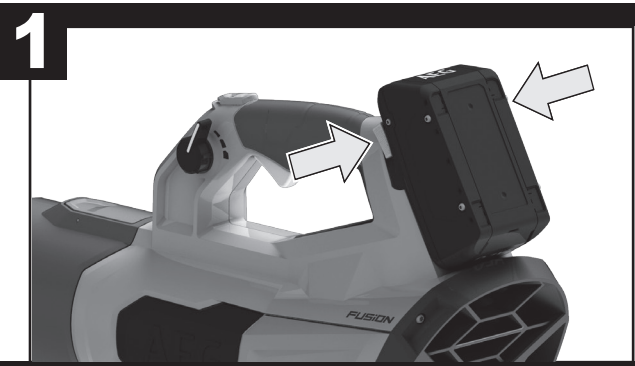

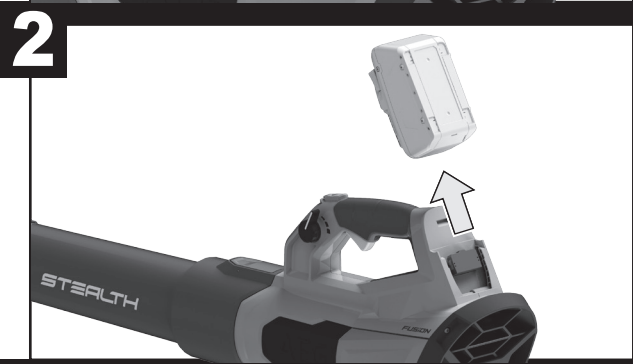
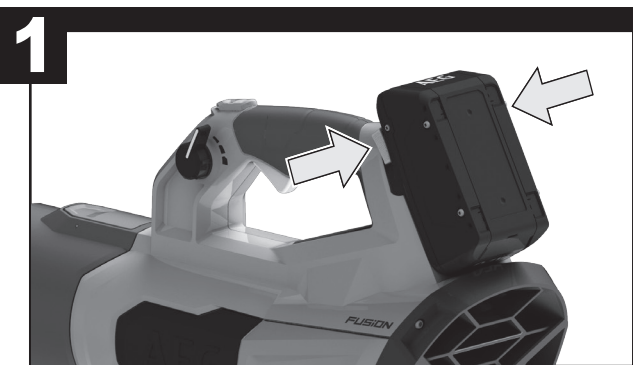
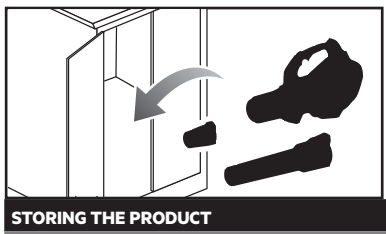

N
d



5

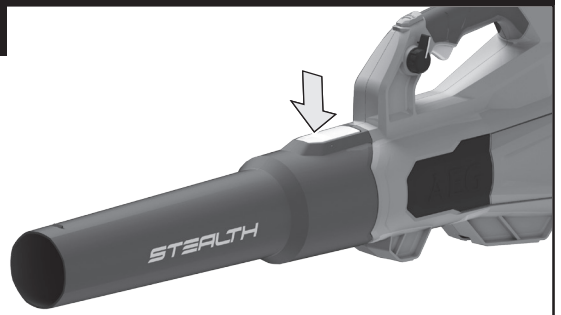

6

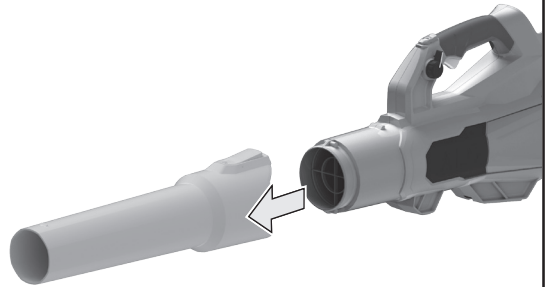

7

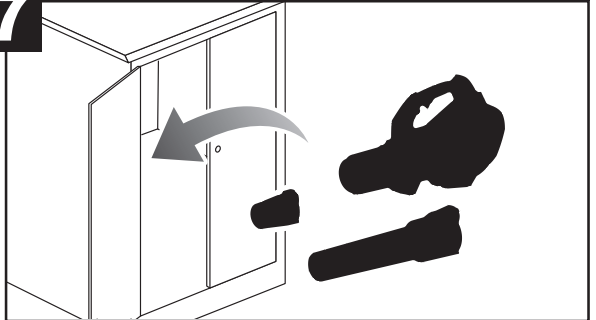

NOTE: Always store the product in a cool, dry, and well-ventilated area.

**TECHNICAL DATA CORDLESS BLOWER****A18FBLW20/A18FBLW28**

Rated voltage	18 V d.c.
Rated current turbo mode.....	38 A
Turbo mode	
Air velocity turbo mode	230 km/h
Air volume turbo mode.....	15.85 m ³ /min
Fan-loaded speed turbo mode	18300/min
Weight without battery pack.....	2.6 kg
Weight with A18OB8 8.0 Ah battery pack.....	3.7 kg
Noise emission level (in accordance with EN 50636-2-100 Annex CC)	
A-weighted sound pressure level at the operator's position.....	$L_{pA} = 78.1 \text{ dB(A)}$
Uncertainty	$K_{pA} = 3.0 \text{ dB}$
A-weighted sound power level	$L_{WA} = 94.2 \text{ dB(A)}$
Uncertainty	$K_{WA} = 3.0 \text{ dB}$
Vibration level (in accordance with EN 50636-2-100 Annex BB)	$a_h = 0.8 \text{ m/s}^2$
Uncertainty	$K = 1.5 \text{ m/s}^2$

WARNING!

The declared vibration total values and the declared noise emission values given in this instruction manual have been measured in accordance with a standardised test and may be used to compare one tool with another. They may be used for a preliminary assessment of exposure.

The declared vibration and noise emission values represent the main applications of the tool. However, if the tool is used for different applications, used with different accessories, or poorly maintained, the vibration and noise emission may differ. These conditions may significantly increase the exposure levels over the total working period.

An estimation of the level of exposure to vibration and noise should take into account the times when the tool is turned off or when it is running idle. These conditions may significantly reduce the exposure level over the total working period.

Identify additional safety measures to protect the operator from the effects of vibration and noise, such as maintaining the tool and the accessories, keeping the hands warm (in case of vibration), and organising work patterns.

BATTERY AND CHARGER

Model	A18FBLW20	A18FBLW28
Battery pack	-	A18OB8
Charger	-	BL1218

Compatible battery packs	A18B4, A18B5, A18FB2, A18FB4, A18FB5, A18OB6, A18OB8, L1820S, L1820SHD, L1830R-X5, L1830RHD, L1840S, L1840SHD, L1850SHD, L1860R-X5/L1860RHD, L1860SHD, L1880SHD, L1890R, L1890RHD
--------------------------	-----------------------------------------------------------------------------------------------------------------------------------------------------------------------------------

INTENDED USE

The cordless blower is intended only for use outdoors in dry and well-illuminated conditions.

The product is not intended to be used by children or persons with reduced physical, mental, or sensory capabilities.

The product is designed for blowing light debris, such as leaves, grass, and other garden refuse.

Do not use the product for any other purpose.

GENERAL SAFETY WARNINGS

⚠ WARNING! Read all safety warnings and all instructions. Failure to follow the warnings and instructions may result in electric shock,

fire, and/or serious injury. Save all warnings and instruction for future reference.

⚠ WARNING! Never allow children or people who are unfamiliar with these instructions to use the product. Local regulations can restrict the age of the operator.

TRAINING

- Read the instructions carefully. Be familiar with the controls and the correct use of the product.
- Keep in mind that the operator or user is responsible for accidents or hazards occurring to other people or their property.
- Do not use the product while tired, ill, or under the influence of drugs, alcohol, or medication.

PREPARATION

- Some regions have regulations that restrict the use of the product to some operations. Check with your local authority for advice.
- Wear hearing protection at all times while operating the product. The product is noisy, and permanent hearing injury may result if precautions to limit your exposure, reduce noise, and wear hearing protection are not strictly adhered to.
- Wear full eye protection at all times while operating the product. The manufacturer strongly suggests a full face mask or fully enclosed goggles. Normal spectacles or sunglasses are not





adequate protection. Objects can be thrown at high speed by the powerful air jet at any time and may rebound from hard surfaces toward the operator.

- While operating the product, always wear substantial footwear and long trousers. Do not operate the product while barefoot or wearing open sandals. Avoid wearing clothing with loose fitting or that has hanging cords or ties.
- Do not wear loose clothing or jewellery that can be drawn into the air inlet. Secure long hair so that it is above shoulder level to prevent entanglement in moving parts.
- Before each use, ensure that all controls and safety devices function correctly. Do not use the product if the off switch does not turn off the product.
- Operate the product in the recommended position and only on a firm and level surface.
- Do not operate the product on a paved or gravel surface where ejected material could cause injury.
- Before each use, always inspect the housing for damage. Ensure that guards and handles are in place and properly secured. Replace worn or damaged components in sets to preserve balance. Replace damaged or unreadable labels.
- Never operate the product while people, especially children, or pets are nearby.
- Keep all cooling air inlets clear of debris.
- Use rakes and brooms to loosen debris before blowing.
- Clear the work area before each use. Remove all objects, such as rocks, broken glass, nails, wire, or string that can be blown a considerable distance by high velocity air.

BATTERY TOOL USE AND CARE

- Recharge only with the charger specified by the manufacturer. A charger that is suitable for one type of battery pack may create a risk of fire when used with another battery pack.
- Use the product only with specifically designated battery packs. The use of any other battery packs may create a risk of injury and fire
- When the battery pack is not in use, keep it away from other metal objects, like paper clips, coins, keys, nails, screws, or other small metal objects that can make a connection from one terminal to another. Shorting the battery terminals together may cause burns or a fire.
- Under abusive conditions, liquid may be ejected from the battery pack; avoid contact. If contact accidentally occurs, flush with water. If liquid contacts eyes, additionally seek medical help. Liquid ejected from the battery pack may cause irritation or burns.
- Do not use a battery pack or product that is damaged or modified. Damaged or modified batteries may exhibit unpredictable behaviour resulting in fire, explosion, or risk of injury.
- Do not expose a battery pack or product to fire or excessive temperatures. Exposure to fire or excessive temperature above 130°C may cause explosion.
- Follow all charging instructions and do not charge the battery pack or product outside the temperature range specified in the instructions. Charging improperly or at temperatures outside the specified range may damage the battery pack and increase the risk of fire.

OPERATION

- Operate the product only at reasonable hours—not early in the morning or late at night when people might be disturbed.
- Never operate the product in an explosive atmosphere.
- Avoid using the product in bad weather conditions, especially when there is a risk of lightning.
- Keep bystanders, children, and pets 15 m away from the area of operation. Stop the product if anyone enters the area.
- Do not operate the product in poor lighting. The operator requires a clear view of the work area to identify potential hazards.
- Operating similar tools nearby increases both the risk of hearing injury and the potential for other persons to enter your working area.
- Always be sure of the footing on slopes. Walk, never run.
- Keep proper footing and balance. Do not overreach. Overreaching can result in loss of balance.
- Never use the product with defective guards or shields, or without safety devices in place.
- Do not modify the product in any way or use parts and accessories that are not recommended by the manufacturer.

⚠ WARNING! If the product is dropped, suffers heavy impact, or begins to vibrate abnormally, immediately turn off the product and inspect for damage or identify the cause of the vibration. Any damage should be properly repaired or replaced by an authorised service centre.

- To reduce the risk of injury associated with contacting rotating parts, always turn off the product and remove the battery pack. Make sure that all moving parts have come to a complete stop:
 - before leaving the product unattended
 - before clearing blockages
 - before checking, cleaning, or working on the product
 - before inspecting the product after striking a foreign object
 - whenever the product starts to vibrate abnormally (inspect immediately)
- Immediately turn off the product and remove the battery pack in the event of accident or breakdown. Do not operate the product again until it has been fully checked by an authorised service centre.

BLOWER SAFETY WARNINGS

- Wear a face filter mask in dusty conditions to reduce the risk of injury associated with the inhalation of dust.
- Slightly dampen surfaces in dusty conditions.
- Do not operate the product near open windows.
- Use the full blower nozzle extension so that the air stream can work close to the ground and perform effectively.
- Do not point the blower nozzle in the direction of people or pets.
- Never place objects inside the blower tubes.
- Do not place the product on top of or near loose debris. Debris can be sucked into the intake vent, resulting in possible damage to the product.

ADDITIONAL BATTERY SAFETY WARNINGS

⚠ WARNING! To reduce the risk of fire, personal injury, and product damage due to a short circuit, never immerse the product,





battery pack, or charger in fluid or allow a fluid to flow inside them. Corrosive or conductive fluids, such as seawater, certain industrial chemicals, and bleach or bleach-containing products, etc., can cause a short circuit.

TRANSPORTATION AND STORAGE

- Turn off the product, remove the battery pack, and allow both to cool down before storing or transporting.
- Remove all foreign materials from the product. Store the product in a cool, dry, and well-ventilated place that is inaccessible to children. Keep the product away from corrosive agents, such as garden chemicals and de-icing salts. Do not store the product outdoors.
- For transportation in vehicles, secure the product against movement or falling to prevent injury to persons or damage to the product.

TRANSPORTING LITHIUM BATTERIES

Transport the battery pack in accordance with local and national provisions and regulations.

Follow all special requirements on packaging and labelling when transporting batteries by a third party. Ensure that no batteries can come in contact with other batteries or conductive materials while in transport by protecting exposed connectors with insulating, non-conductive caps or tape. Do not transport batteries that are cracked or leaking. Check with the forwarding company for further advice.

MAINTENANCE

- Use only original manufacturer's replacement parts, accessories, and attachments. Failure to do so can cause possible injury, can contribute to poor performance, and may void your warranty.
- Servicing requires extreme care and knowledge and should be performed only by a qualified service technician. Have the product serviced by an authorised service centre only. When servicing, use only original replacement parts.
- Do not make adjustments and repairs that are not described in this manual. For other repairs, contact an authorised service centre.
- After each use, clean the product with a soft, dry cloth.
- Check all nuts, bolts, and screws at frequent intervals for proper tightness to ensure that the product is in safe working condition. Any part that is damaged should be properly repaired or replaced by an authorised service centre.
- Bring the product to an authorised service centre to replace damaged or unreadable labels.

CLEARING A BLOCKAGE

- To reduce the risk of injury associated with contacting rotating parts, always turn off the product, remove the battery pack, and make sure that all moving parts have come to a complete stop.
- Remove the blower tubes to inspect for blockage. Clear the tubes if required.
- Reinstall the blower tubes before starting the product.

RESIDUAL RISKS

Even when the product is used as prescribed, it is still impossible to completely eliminate certain residual risk factors. The following

hazards may arise during use, and the operator should pay special attention to avoid the following:

- injury caused by vibration
 - Always use the right tool for the job, hold the product by the designated handles and use the lowest speed necessary to achieve the task.
- injury caused by exposure to noise
 - Wear ear protection and limit exposure.
- injury caused by flying objects from the blower tube airflow
 - Wear eye protection at all times.

RISK REDUCTION

It has been reported that vibrations from handheld tools may contribute to a condition called Raynaud's Syndrome. Symptoms may include tingling, numbness, and blanching of the fingers, usually apparent upon exposure to cold. Hereditary factors, exposure to cold and dampness, diet, smoking, and work practices are all thought to contribute to the development of these symptoms. There are measures that can be taken by the operator to possibly reduce the effects of vibration:

- Keep your body warm in cold weather. When operating the product, wear gloves to keep the hands and wrists warm. It is reported that cold weather is a major factor contributing to Raynaud's Syndrome.
- After each period of operation, exercise to increase blood circulation.
- Take frequent work breaks. Limit the amount of exposure per day.

If you experience any of the symptoms of this condition, immediately discontinue use and see your physician.

⚠ WARNING! Injuries may be caused or aggravated by prolonged use of the product. When using the product for prolonged periods, ensure to take regular breaks.

SYMBOLS ON THE PRODUCT



Read and understand all instructions before operating the product. Follow all warnings and safety instructions.



Beware of thrown or flying objects. Keep all bystanders, especially children, and pets, at least 15 m away from the operating area.



Rotating fans. Keep hands and feet out of openings while the product is running.



Wear ear protection.

PLACEHOLDER





Wear eye protection.



Do not expose the product to rain or damp conditions.



Remove the battery pack before starting any work on the product.



Keep hands away from rotating parts.



Risk of long hair being drawn into air inlet.



Risk of loose clothing being drawn into the air intake.



Guaranteed sound power level



Regulatory Compliance Mark (RCM). Product meets applicable regulatory requirements.



Waste electrical products should not be disposed of with household waste. Please recycle where facilities exist. Check with your local authority or retailer for recycling advice.

SYMBOLS IN THIS MANUAL



Note



Warning



Parts or accessories are sold separately

The following signal words and meanings are intended to explain the levels of risk associated with this product.

⚠ DANGER

Indicates an imminently hazardous situation, which, if not avoided, will result in death or serious injury.

⚠ WARNING

Indicates a potentially hazardous situation, which, if not avoided, could result in death or serious injury.

⚠ CAUTION

Indicates a potentially hazardous situation, which, if not avoided, may result in minor or moderate injury.

CAUTION

Without safety alert symbol

Indicates a situation that may result in property damage.

PLACEHOLDER

AEG

www.aegpowertools.com.au
www.aegpowertools.co.nz

Techtronic Industries Australia Pty Ltd

31 Gilby Road, Mount Waverley,
VIC, 3149, Australia

Techtronic Industries N.Z. Limited

Unit C, 70 Business Parade South,
Highbrook, Auckland 2013, New Zealand

*AEG is a registered trade mark used under
license from AB Electrolux (publ).*

XXXXXXXX-01